



GE Security



ESL 1500 Series

Fire Alarm Control Panel

Installation and Operations Manual

Table of Contents

Precautions and Warnings	1
System Overview	1
Panel Listing	1
Panel Description	2
Ordering Information	2
Installing the Panel	3
Optional Zone Expansion and Communicator Module Installation	4
Panel Controls	4
Control Switches	4
Normal Condition	5
Alarm Condition	5
Alarm Verification	5
Zone Disconnect	5
System Reset	6
Trouble Condition	6
Supervisory Functions	6
Remote Test (Drill)	6
Field Wiring	7
Installation Recommendations/Precautions	9
Field Wiring Checkout Procedures	10
Alarm Initiating Devices	10
Alarm Indicating Devices	11
Connecting Supplementary Contacts	11
Connecting Optional Remote Notification Devices	13
Programming	14
BMB Programming	14
ZEM Programming	14
Testing and System Checkout	15
Maintenance	15
Troubleshooting	16
Specifications	17
Appendix A, Compatible Equipment	18
Appendix B, Standby Battery Power Worksheet	20
Appendix C, 1500 Series Operating Instructions	21

Figures and Tables

Figures

Figure 1. Internal Panel Configuration	3
Figure 2. ZEM or LEM Installation	4
Figure 3. Window Label Installation	4
Figure 4. Template Diagram	6
Figure 5. Class A System Wiring Diagram	7
Figure 6. Class B System Wiring Diagram	8
Figure 7. Power Limited Routing	9
Figure 8. Zone Relay Module (ZRM) Wiring Diagram	12
Figure 9. Zone Relay Module (ZRM) Placement	12
Figure 10. Terminal Connections	12
Figure 11. Local Energy Module (LEM) Wiring Diagram	13
Figure 12. BMB Default Settings	13
Figure 13. ZEM Default Settings	14
Figure 14. ZEM Programming Switches Location	14

Tables

Table 1. Ordering Information	2
Table 2. Status Indicators	5
Table 3. Wire Resistance	9
Table 4. Alarm Indicating Circuit Wire Size	9
Table 5. BMB Programming Features	14
Table 6. ZEM Programming Features	14
Table 7. Troubleshooting Guide	16
Table 8. Compatible Indicating Devices	18
Table 9. Two-Wire Smoke Detector Compatibility	19
Table 10. Four-Wire Smoke Detector Compatibility	19

Panel Description

Standard Features:

- Modular design; 1, 3, or 5 zones
- Power limited
- 1.5 Amp, 24 VDC FWR output
- All functions DIP switch activated
- Built-in walktest and alarm verification
- Sprinkler supervisory and waterflow alarm activation
- Class A (Style D) or Class B (Style B) initiating wiring
- Reliability of surface-mount design
- Superior lightning protection

Optional Features:

- Local Energy Module (LEM)
- Zone Relay Module (ZRM) 5 relays
- Remote Annunciators (RA)

Table 1. Ordering Information

Model	Title	Description
1501	Single zone fire panel	1 initiating circuit, 2 indicating circuits
1503	Three zone fire panel	3 initiating circuits, 2 indicating circuits
1505	Five zone fire panel	5 initiating circuits, 2 indicating circuits
1500-BMB	Basic Master Board	1 initiating circuit, 2 indicating circuits
1500-ZEM	Zone Expansion Module	2 initiating circuits, Class A or B
1500-LEM	Local Energy Module	Connect to Listed master box
1500-ZRM-5	1500 Zone Relay Module	5 relays
1500-SH	System housing	System housing with transformer
1500-TK	Flush mount trim ring	Mounting panel semi-flush with wall
1500-TR	Transformer	Transformer replacement
1500-2.7	End-of-line resistor	Initiating and indicating circuits 2.7 Ky 1/2 W
1500-RA-5A	Remote Annunciator	5 alarm zones w/ trouble and sounder
204-12/24 V	Power supervision unit	EOL power supervisory unit
405-01	Polarity reversal relay	Single circuit, 24 VDC

Installing the Panel

To install the unit, follow these 12 steps, and refer to the proper sections for more information.

1. **Create System Diagram:** Prepare a carefully laid out drawing of the complete wiring system hookup. Maintain this drawing as a permanent record of the system application and include any future modifications.

Note: “As-built” drawings and this manual should be available at all times to verify agreement between the connected equipment and the drawings.
2. **Inspect Equipment:** Carefully unpack the system components and inspect for shipping damage. Report any shipping damage to place of purchase.
3. **Mount Cabinet:** Mount the cabinet in a clean, dry, vibration-free area, where the temperature range does not exceed 0° to 49° C (32° to 120° F). Mount only in interior locations. Allow adequate space for 180 degree door swing and free access to sides for conduit entry. Locate the top of the cabinet approximately 6 feet (1.8m) above the floor, with the hinge mounting on the left. Mounting holes in the back of the cabinet are designed so the cabinet can be mounted without removing any control equipment. Mount the cabinet to the wall by first installing the top center mounting screw, leaving enough space so the cabinet can be hooked over the screw head. Use screws or bolts no smaller than #10 or 3/16 inches in diameter. For easier access, remove the door by gently lifting it from the hinges.
4. **Connect Conduit:** Complete all connections to the cabinet with conduit fittings or bushings. Use the knockouts provided in the sides of the cabinet.
5. **Pull Wire:** Pull all system wiring through installed conduit following the guidelines of Article 760 of the National Electrical Code (NFPA 70) and/or local codes for fire alarm systems. Observe power limiting codes when running wire. See *Installation Recommendations/Precautions* for more information.
6. **Program Components:** Before wiring, examine installation of all modules, chassis and sub-assemblies to ensure proper mechanical and electrical connections and programming switches have been selected. See *Programming* for options.
7. **Connect AC:** Connect line voltage to transformer leads located under the BMB. Transformer wires are long enough so you do not need to remove the circuit board.
8. **Connect Batteries:** Determine the total system power requirements by using the *Standby Battery Power Worksheet* in Appendix B.
9. **System Check:** Make certain the 1500 panel is operating properly before connecting field wiring by performing a system check. ESL makes this easy by factory installing end-of-line resistors to the proper Class B zone terminals. To test the panel, make sure all switches are in their normal position and power the system by connecting AC and then the batteries. (Note: if new batteries with low terminal voltage are used, the Low/No Battery LED may activate. The Low Battery indicator will deactivate after the batteries are fully charged - no longer than 48 hours.) No fault indications should be present. If faults are present, see Table 6. *Troubleshooting Guide*. System check is now complete.
10. **Check Field Wiring:** Check the integrity of all field wiring following directions defined in the *Field Wiring Checkout Procedures*. This check must be performed before connecting wiring to the system. Be certain all external wiring is correct (no opens, shorts, or grounds) and is terminated with the correct end-of-line devices.
11. **Connect Field Wiring:** Connect each circuit **in turn**, following wiring diagrams provided. **Do not make all connections at once**. This procedure will let you bring your system on-line in stages and quickly identify which portion of your system is not working.

Note: NFPA 72, Chapter 7 - Inspection, Testing, and Maintenance should serve as the guideline for all system tests.
12. **Test System:** Apply power and perform operational tests as outlined under *Testing and System Checkout*.

⚠ CAUTION

Read and understand all instructions before beginning installation. System reliability depends upon proper installation, testing, and maintenance. Review all national and local codes before attempting installation. Refer to National Fire Alarm Code (NFPA 72) for proper location, mounting, etc. of smoke detectors, heat detectors, and other alarm initiating devices. Call Technical Support at 800.648.7424 if you have installation questions.

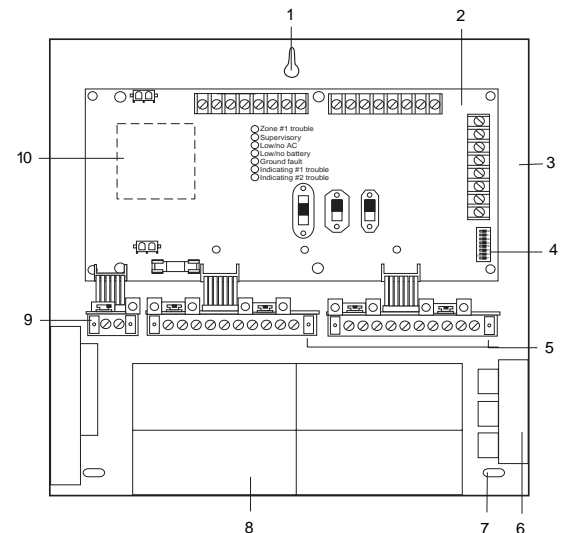

1. Mounting hole
2. Basic Master Board (BMB)
3. Housing backbox
4. Programming switches
5. Zone Expander Modules (ZEM)
6. Mounting location for Zone Relay Module 1500-ZRM-5
7. Mounting hole (TYP)
8. Battery area
9. Local Energy Master Box Trip Module 1500-LEM
10. 1500-TR Transformer

Figure 1. Internal Panel Configuration

Optional Zone Expansion and Communicator Module Installation

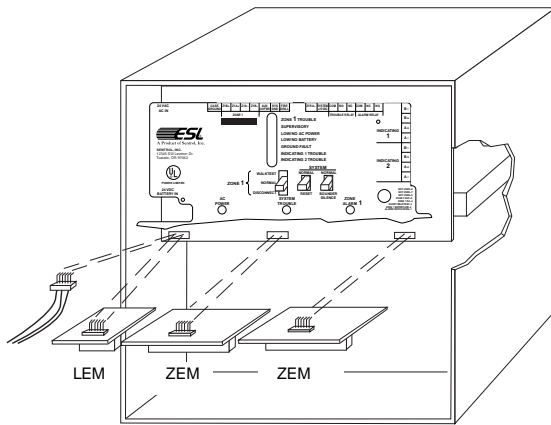

Figure 2. ZEM or LEM Installation

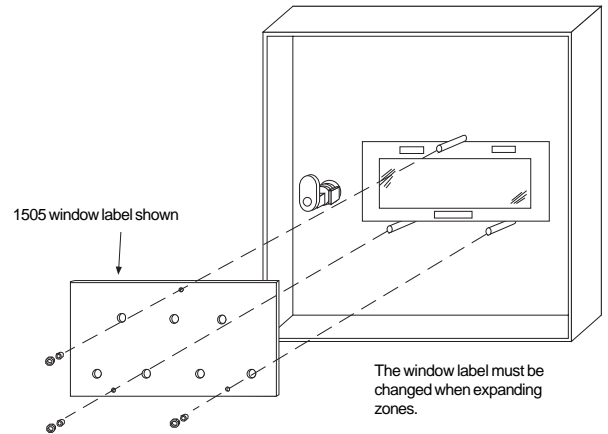

Figure 3. Window Label Installation

Panel Controls

Control Switches

System Reset

Resets control unit, provided the alarm condition has been cleared. Also interrupts power to the alarm initiating circuits of all zones and to the auxiliary power output. The integral sounder will activate when the System Reset switch is activated.

Sounder Silence

Activating the switch during a trouble condition will silence the integral sounder. When all system faults are cleared, a “ringback” feature will resound the integral sounder to indicate that the switch is in the silence position. Fault LEDs will remain active until all faults have been corrected.

Zone Disconnect/Walktest

A three position switch provides for normal, test, and disable functions for each zone. Under standard conditions, no LEDs will light when the switch is in the “normal” position.

Note: For maintenance use only! Notify your local fire department and receiving station before operating switch.

Zone Disconnect disables the alarm indicating devices so that service may be performed without sounding an alarm. When a zone is disabled, zone and system trouble LEDs will light and the integral trouble sounder will activate. An alarm received from any zone that has not been disabled will activate the indicating devices as normal. The zone disconnect switch is defeated when a zone has been programmed for waterflow service. See *BMB Programming*.

Walktest makes it possible for one service person to functionally test initiating devices without having to constantly return to reset the control panel. When activated, the walktest feature sounds the indicating devices for approximately two seconds and then resets the system. Only an alarm from the zone with the walktest activated will reset the system; all other zones will function normally. To silence the indicating devices during the walktest mode, see *BMB Programming*.

Optional Remote Notification Disconnect

Applies to LEM optional module. Disconnects system from remote sites. When activated, the trip circuit fault LED and system fault condition will exist and remain until the switch is returned to the normal position.

Note: Notify the local fire department and the receiving station before disconnecting the LEM from the system.

Normal Condition

Under normal operating conditions only the green “AC POWER” LED should be on (no alarm or faults). All control switches must be in their normal, standby position.

Alarm Condition

An alarm can be initiated by means of a smoke detector, heat detector, manual alarm station, waterflow alarm device, or other UL Listed initiating device. The red zone alarm LED will light and the integral sounder will provide a continuous, steady audible signal. Both alarm indicating circuits will activate and sound a general alarm. A set of dry, Form C supplementary common alarm contacts will transfer and remain latched until the system RESET switch is operated. When used, the supervised zone alarm output will energize. If provided, the remote communicator circuit will activate to summon organized assistance.

Alarm Verification

When activated, alarm verification is very effective in reducing nuisance alarms. Nuisance alarms are reduced by requiring 2 separate alarm signals to activate the system. When the first alarm is received from an initiating device, the verification feature inhibits an alarm output for approximately 12 seconds. After this period, power is reapplied to the initiating circuits. If a second alarm signal is received within 2 minutes, a system alarm is generated; if not, the system resets and no alarm is generated. **An alarm from a manual station or heat detector, however, is never delayed more than 15 seconds.** To activate alarm verification, see *BMB Programming*.

Note: When using alarm verification, total alarm delay (alarm verification + smoke detector power-up time) cannot exceed 60 seconds according to the National Fire Alarm Code (NFPA 72) or 30 seconds for installations governed by the California State Fire Marshall. Alarm delay includes verification time (12 seconds) and smoke detector power-up time. Smoke detector power-up time varies by manufacturer, however, the ESL 429, 449, 521, 541, 500N, and 700 Series detectors meet both CSFM and NFPA requirements (ESL detector power-up time is 15 seconds). During alarm verification, the Zone LED, Remote Annunciator and the Zone Relay Module (ZRM) may activate briefly (approximately 12 seconds) during the initial alarm signal.

Zone Disconnect

Note: For maintenance use only! Notify local fire department and receiving station before operating the switch if the control panel is monitored, as a “trouble” signal will be transmitted.

When activated prior to an alarm condition, this switch disconnects the local zone alarm from the auxiliary alarm relay and alarm indicating circuits. When activated, the red local alarm zone LED turns on and, if used, the supervised remote annunciator LED lights. Only the disconnected zone is affected; alarm signals from other zones remain active.

When activated after an alarm condition, the auxiliary alarm relay remains latched and alarm indicating circuits are turned off. The red local alarm zone LED remains on and, if used, the supervised remote annunciator remains on. Only the disconnected zone is affected; alarm signals from other zones remain active. Additionally, if an initiating device is still in alarm when a zone disconnect switch is returned to normal, the alarm will again be transmitted to both the alarm indicating circuits and the integral sounder.

Table 2. Status Indicators

Indicator	Normal	Color	Description
AC Power	On	Green	Indicates main power is operating from AC power source. If LED not activated, service immediately.
System Trouble	Off	Yellow	Indicates fault or abnormal condition. May indicate system is inoperable; service immediately.
Zone Alarm (by zone)	Off	Red	Indicates when an alarm condition is detected by its zone.

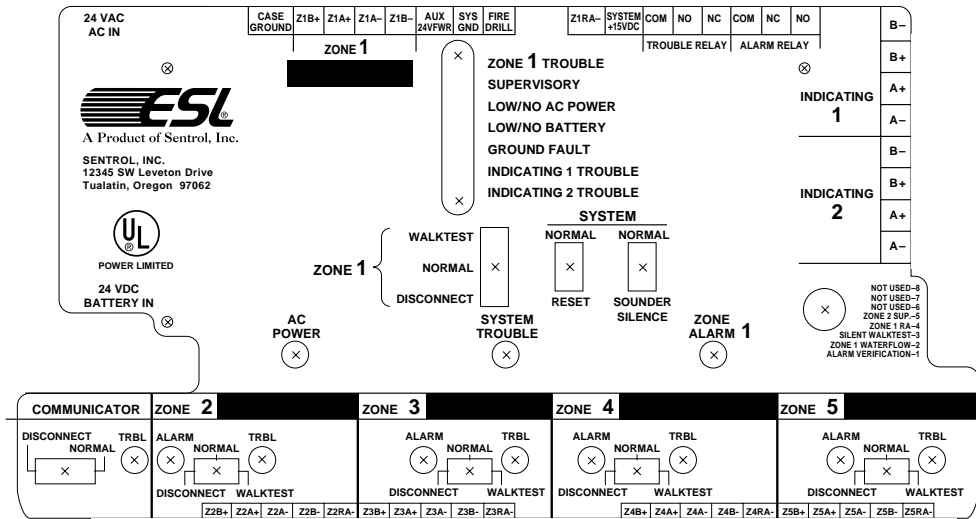

Figure 4. Template Diagram

System Reset

System reset can only be accomplished when all actuated alarm devices have been restored to their normal, standby condition.

Note: Operating the system reset switch will return all alarm initiating circuits and system-powered initiating devices to their normal standby condition. Mechanical initiating devices such as most fixed temperature heat detectors and manual stations must be replaced or manually reset or the system will alarm again when the reset switch is released.

Trouble Condition

Activation of the fault signal under normal operation indicates a condition that requires immediate correction. A fault signal involves illumination of the system trouble LED (yellow) and individual diagnostic LED's (yellow) generally associated with the specific circuit affected. The integral sounder will sound a slow intermittent signal and a set of dry, Form C contacts will transfer. Moving the SOUNDER SILENCE switch to the silence position will silence the audible trouble signal, but will not restore the Form C contacts. Restoration to normal can only be achieved when all faults have been corrected and all switches have been returned to normal position. Trouble reset occurs automatically when this is accomplished. If the SOUNDER SILENCE switch is off-normal at the time all faults are clear, the "ringback" feature will alert the operator.

Supervisory Functions

Zone 2 of the control panel can be programmed for supervisory service. A common supervisory application would include sprinkler water valve tamper switch monitoring. During a supervisory alarm, the integral sounder activates a rapidly pulsing tone and the zone 2 red local alarm LED lights. In addition, the supervisory LED on the BMB will activate. During supervisory trouble, the integral sounder activates a rapidly pulsing tone, zone 2 yellow local trouble LED lights and the system trouble relay contacts transfer.

Remote Test (Drill)

A remote test (drill) function is provided for testing the 1500 System. Closing a listed normally-open switch connected to terminals "SYS GND" and FIRE DRILL" (see Figure 5) will result in actuating both the alarm indicating circuits and the integral sounder. The common alarm relay will not operate, nor will an optional remote notification circuit. Any alarm signaling devices connected to the indicating circuits will be activated. During the test/drill, the indicating supervisory circuit will be tested as well, resulting in the illumination of the indicating circuit fault LED's and the system trouble LED. The integral sounder will sound a slow intermittent signal.

Field Wiring

Class A System Wiring Diagram

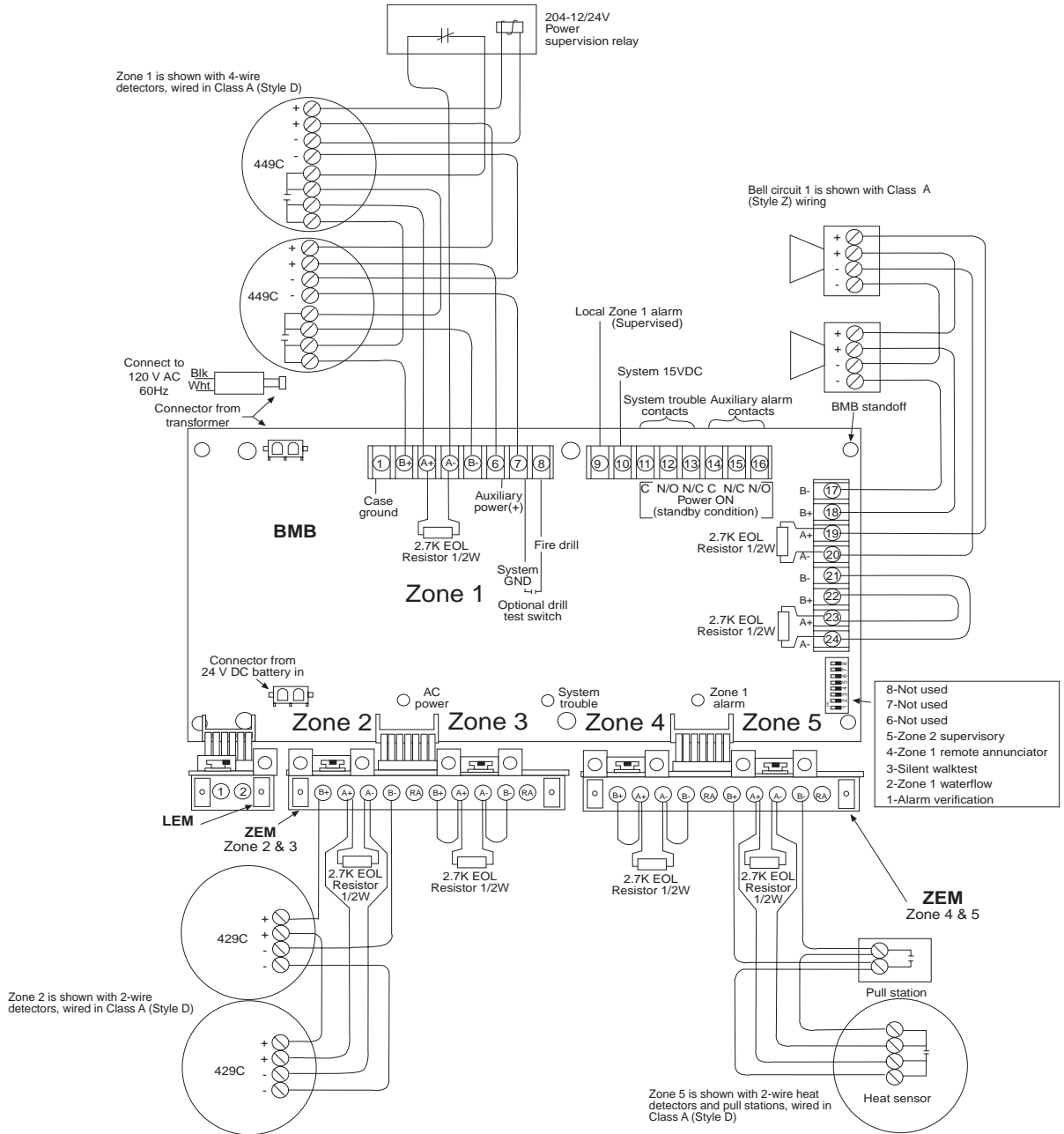

Figure 5. Class A System Wiring Diagram

Class B System Wiring Diagram

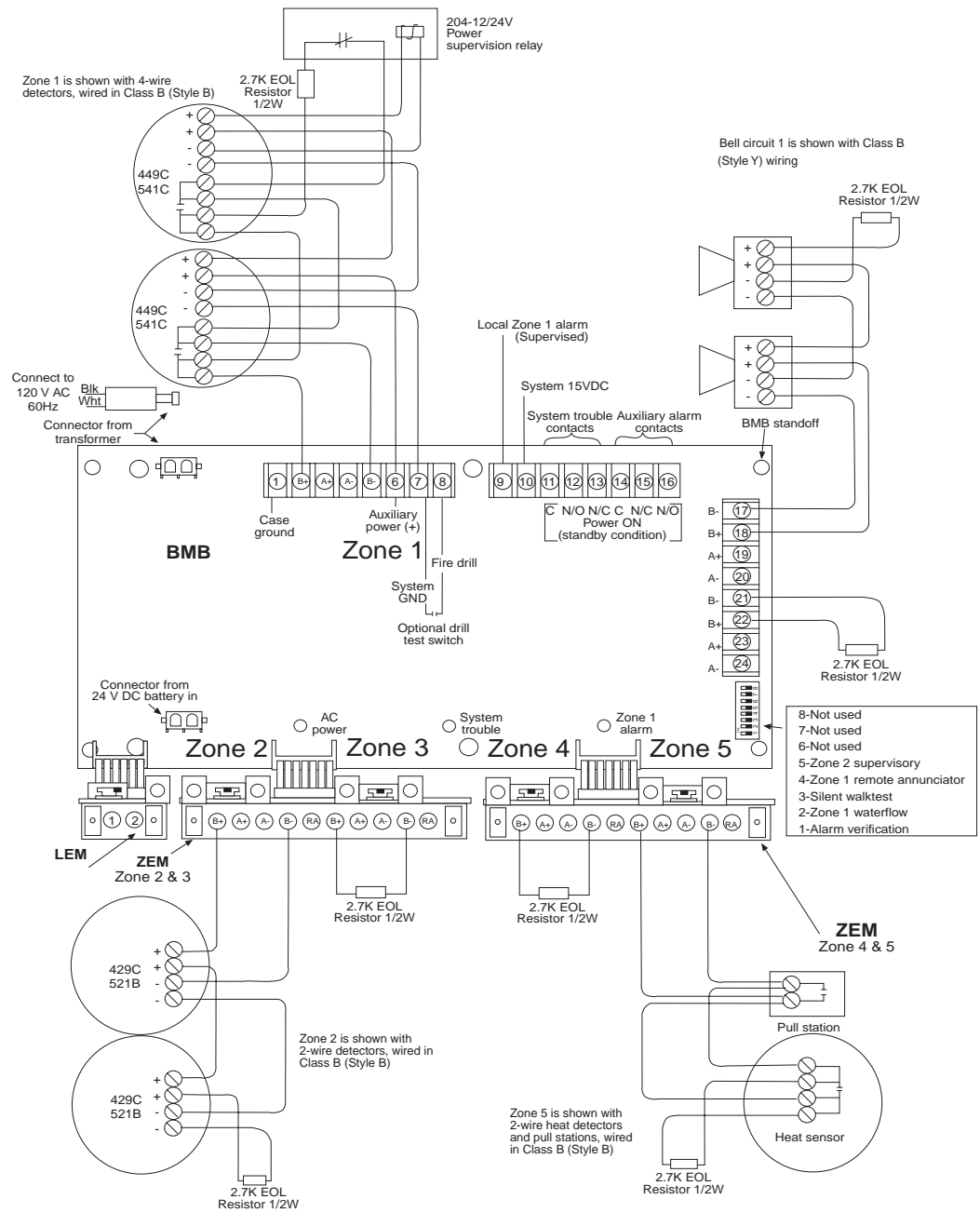
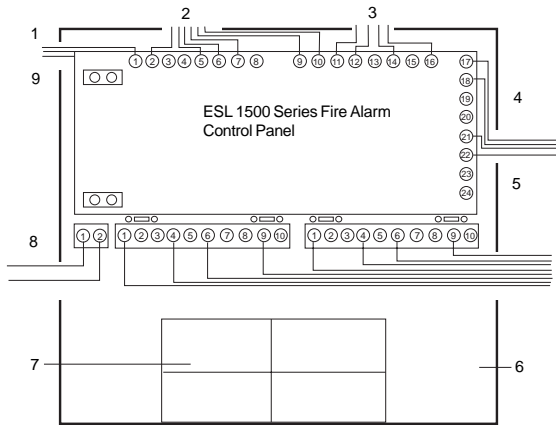

Figure 6. Class B System Wiring Diagram



1. Case ground
2. Power limited Zone 1 and Remote Annunciator
3. Non-power limited trouble and alarm contacts
4. Power limited bell circuits
5. Power limited Zone 2 through 5 and Remote Annunciator
6. Housing backbox
7. Battery area
8. Non-power limited LEM
9. Non-power limited 28 VAC

Figure 7. Power Limited Routing

Table 3. Wire Resistance

Gauge	Ohms per 1000 ft. @ 20°C of single conductor copper wire
12	1.6
14	2.5
16	4.0
18	6.4
20	10.0
22	16.0

Table 4. Alarm Indicating Circuit Wire Size

Total device load (Amps)	Max. ft. of paired wire from B+ to EOL resistor			
	18AWG	16AWG	14AWG	12AWG
.100	1500	2500	4000	6200
.500	300	500	800	1290
1.000	150	250	400	620

(Maximum voltage drop allowable: 2 VDC)

Installation Recommendations/Precautions

Note: The 1500 System is capable of power limited operation per NEC Article 760, Section C. All circuits are power limited except: CASE GND, TRB COM, TRB NO, ALM COM, ALM NC, and LEM terminals. Non-power limited circuits must be separated from power limited circuits by a minimum of 1/4 inches (0.6cm). See Figure 7 for one method of routing power limited wiring.

CAUTION

Do not route LEM field wires in close proximity of high voltage wiring. LEM field wiring must not exceed 3280 feet (1000m).

Verify wire sizes are adequate for all indicating and initiating circuits. The maximum allowable initiating zone resistance is 100 Ohms. (Exception: When ESL 2-wire smoke detectors with integral sounders are used, maximum initiating zone resistance is 50 Ohms. See Table 3.)

Many audible/visual signaling appliances cannot tolerate more than a 20 percent voltage drop from the specified device voltages. See Table 4 to determine maximum distance for wire gauge used.

Incoming AC voltage should be stable at a nominal 120 volts. This is especially important in new construction where incoming power may be high or unstable with temporary connections often causing large, inductive voltage spikes.

Ground the system properly. The AC input, power supply/battery charger should use an isolated ground, not a conduit ground. Do not connect this system to a conduit or green wire circuit that also is used to power resistance heating, motors, fans, air conditioning equipment, or florescent lighting circuits since leakage currents into the ground return could damage system components. A separate earth ground or cold water pipe with properly bypassed water meter should be used. Provide a separate earth ground, if water mains are non-conductive.

Run signal wires separately. Most supervised circuits use voltage or current sensing circuits which are very sensitive to induced voltages on the sensor wiring. Therefore, under no circumstances run AC power, speaker, public address, intercom, or switch control wiring with inductive loads in the same conduit or in the immediate vicinity of the control wiring.

Do not overlook adequate lightning protection. Lightning damage commonly occurs from three sources:

1. Through alarm loop wiring
2. Through AC power inputs
3. Through earth ground or power ground connections

The 1500 System has substantial lightning protection incorporated in all three areas. However, proper lightning protection for AC power must be accomplished where the wire enters the building. Arrestor circuitry and earth grounding should be in accordance with Article 250 of the National Electrical Code.

There is no known protective device available which is capable of protecting equipment from damage caused by “direct hit” strikes of lightning due to the extremely high energy released (10 million to 100 million volts @ 10,000 to 30,000 amps). However, line surges from indirect strikes can be minimized.

Additional protection is suggested in areas subject to above-average lightning activity or induced voltage spikes and fluctuations due to power line load switching.

Field Wiring Checkout Procedures

Note: Make sure that AC and battery power are disconnected before proceeding.

1. Test all field wiring before connecting any equipment.
 - A. Make sure no unwanted voltages are present on circuit conductors and ground. They are a hazard and may prevent proper system operation.
 - B. All wiring except those intentionally and permanently grounded must be tested for isolation from ground using an insulation testing device such as a “Megger”.

Note: Caution must be exercised when using voltage generating test instruments such as a “Megger”. Damage to equipment could result if the equipment is connected (wired) during wiring tests.
 - C. All wiring, other than those intentionally connected together, must be tested for conductor-to-conductor isolation using an insulation testing device.
2. With each circuit pair short-circuited at the end of the circuit, measure circuit resistance with an ohmmeter. Record the circuit resistance of each circuit and store this data with the control panel. Loop resistance must be less than 100 ohms on initiating zones.
3. Perform testing as described previously after any addition, deletion, or mechanical or electrical damage to the system has occurred.
4. A periodic test should be performed in accordance with the schedules recommended in NFPA 72, Chapter 7, or more frequently, if required by the authority having jurisdiction. Whenever possible a 100 percent test should be performed. When less than a 100 percent test is performed, a record must be maintained of the devices tested each time, so different devices are tested in subsequent tests.

Alarm Initiating Devices

This section describes how to field wire initiating devices such as smoke detectors, pull stations, and heat detectors. Refer to Figure 5 for Class A (Style D) and Figure 6 for Class B (Style B) wiring.

Two-Wire Smoke Detectors, Heat Detectors, and Manual Pull Stations

- Connect only two-wire smoke detectors UL Listed as compatible to the 1500 Series Fire Control Panel. Refer to the list of compatible detectors in Appendix A.
- Two-wire detectors receive their power direct from the zone terminals and transmit the alarm signal via the same wires. Be certain to observe polarity when installing detectors.
- All initiating devices must be wired sequentially for proper supervision with the end-of-line resistor (2.7K Ohm 1/2 W) installed after the last device. ESL has detectors available with EOL built in.

Four-Wire Smoke Detectors

- Four-wire detector power is shared with indicating circuits; **do not** exceed total power requirements of 1.5 Amps.
- Always supervise four-wire detector power with an end-of-line power supervisory device (ESL model 204-12/24V) after the last unit.

See Figure 5 for Class A (Style D) wiring and Figure 6 for Class B (Style B) connection to the panel.

Sprinkler System Waterflow and Supervisory Devices

Normally open contact type waterflow alarm devices may be connected, along with conventional manual alarm stations or heat detectors. All zones to which waterflow alarm devices are connected may be programmed so that the system alarm indicating devices cannot be silenced. See *Programming*.

Supervisory signals for status reporting of waterflow control valves, supplies, etc. must be connected to a separate zone, and programmed for supervisory status. Only Zone 2 can be programmed for this feature. See *Programming*.

Alarm Indicating Devices

Use only polarized UL Listed signaling devices rated for 24 VDC (see the list of devices in Appendix A). See Figure 5 for Class A (Style Z) wiring and Figure 6 for Class B (Style Y) connection to the panel.

Note: Maximum indicating current per circuit is 1 Amp; however, total operating current cannot exceed 1.5 Amps. Choose the correct wire size for maximum voltage drop of 2 VDC at the furthest device on the circuit (see Table 3). Supplementary Alarm and Trouble Contacts are for power limited applications only.

Connecting Supplementary Contacts

Note: Supplementary Alarm and Trouble Contacts are for power limited applications only (see *Installation Recommendations/Precautions*). When supplementary contacts are connected to a power limited circuit, these outputs meet power limited code and do not require separation.

Supplementary Alarm Contacts

Dry, Form C contacts are provided for controlling supplementary alarm functions from the BMB. Contacts are rated 2A @ 30 VDC resistive. Terminals are ALM COM, ALM NC, and ALM NO. Contacts transfer in alarm.

Supplementary Trouble Contacts

Dry, Form C contacts are provided for controlling supplementary fault functions from the BMB. Contacts are rated 2A @ 30 VDC resistive. Terminals are TRB COM, TRB NC, and TRB NO. The trouble relay is normally energized and will activate even if both AC and battery power are removed.

Optional Zone Relay Module (ZRM)

Additional relays may be added using the optional ZRM-5. Make electrical connections using Figure 8. After connections are made, use directions in *Installing Optional ZRM and Snap Track* to finish the installation.

Installing Optional ZRM and Snap Track

- 1 Remove the protective tape from the adhesive mounting strip on the snap track supplied with the unit.
- 2 Mount the snap track on the lower, right side of the cabinet. See Figure 9.
- 3 Using the slots in the snap track as a template, drill two holes through the cabinet side wall, one near each end of the snap track, using a #13, #14, #15, or 3/16" diameter drill and deburr.
- 4 Install the supplied push rivets from the outside of the cabinet through both the cabinet side wall and the snap track, driving the push pins flush with the rivet head. In semi-flush mounting installations, install the push rivets from the inside of the cabinet.
- 5 Complete electrical connections between the ZRM and the BMB before mounting it to the snap track. Then snap the connected ZRM into the snap track with the terminals toward the front of the cabinet.
- 6 Dress wire leads to comply with the requirements of the National Electrical Code, Article 760, Section C.

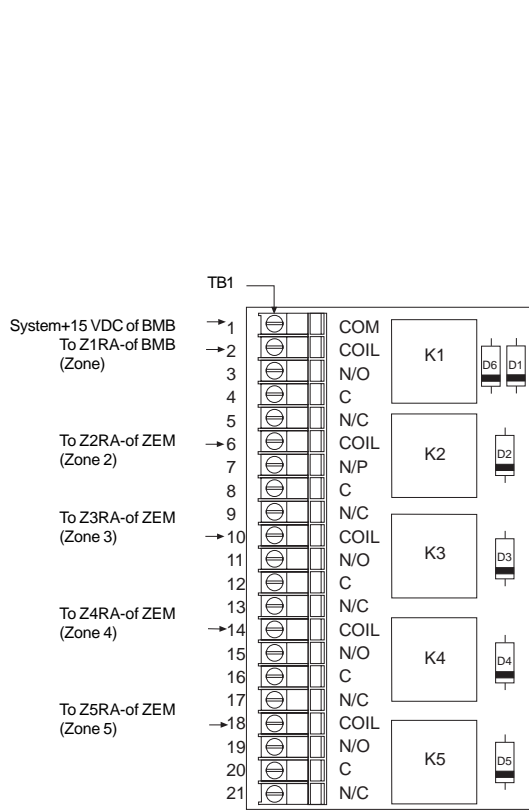

Figure 8. Zone Relay Module (ZRM) Wiring Diagram

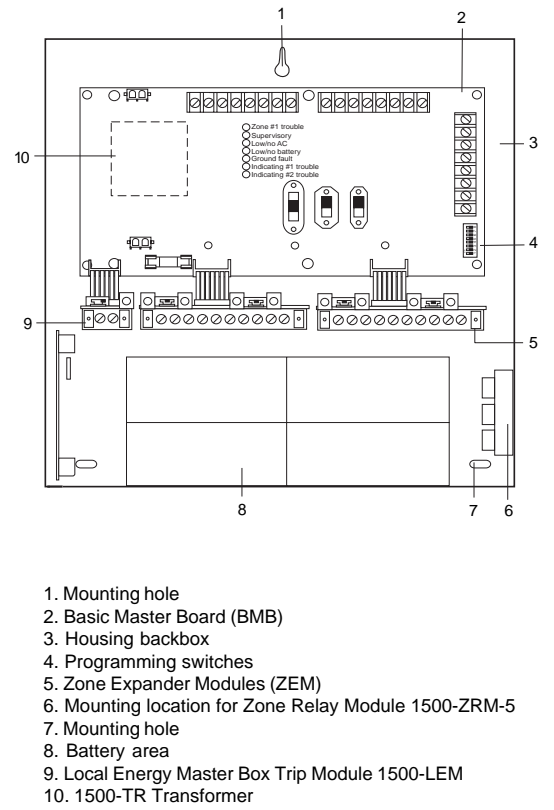

Figure 9. Zone Relay Module (ZRM) Placement

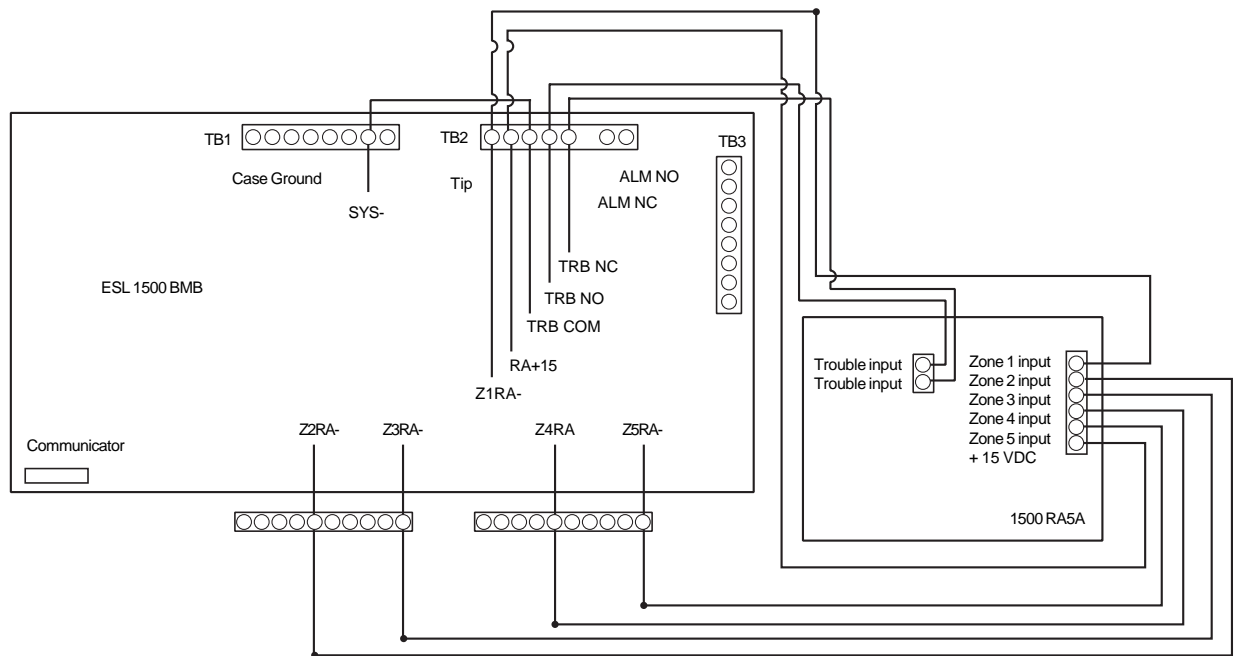

Figure 10. Terminal Connections

Connecting Optional Remote Notification Devices

1500-RA-5A

Note: When using remote annunciators other than the ESL 1500-RA-5A, be sure all circuits have a series resistance of at least 1K ohm. Maximum current should be 15mA per zone.

The control unit can properly power one remote annunciator. When a remote annunciator is used, both the BMB and ZEM must be programmed to provide supervision. See *Programming*. The remote annunciator circuit is supervised as long as no other devices are connected to the same terminals; otherwise, the devices will not be supervised. See Figure 10 for the wiring diagram.

1500-LEM

The Local Energy Module (LEM) trip circuit is designed to interface to a Listed Master Box with a local energy trip mechanism. This optional module provides a supervised trip circuit from the 1500 system that activates the Master Box upon a system alarm. Make connections as detailed in Figure 11.

For systems which include remote annunciation 1500-RA-5A, use Figure 10. **Remove all power from the system before beginning procedure.**

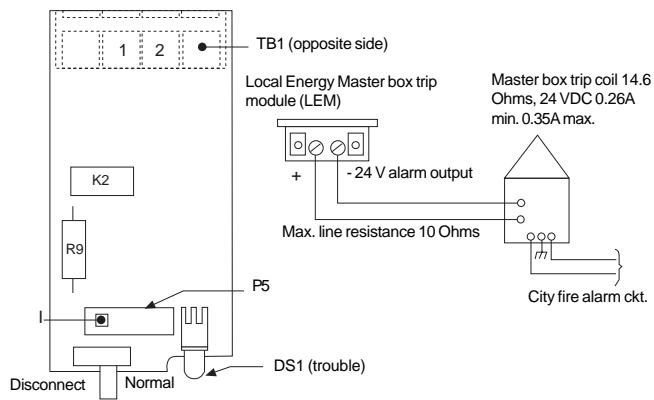

Figure 11. Local Energy Module (LEM) Wiring Diagram

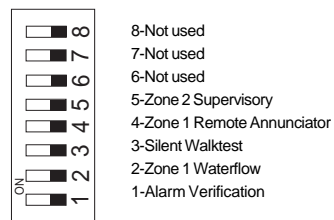

Figure 12. BMB Default Settings

Programming

BMB Programming

All programming selections are controlled by switches located in the lower right corner of the BMB. Table 5 shows default (factory) programming along with a description of each feature.

Table 5. BMB Programming Features

Switch #	Factory Position	Feature	Description
8,7,6	off	not used	not used
5	off	zone 2 supervisory	Disables fire alarm signal and provides distinctive audible and visual supervisory signals. Must also program ZEM zone 2 switches 3, 4, 5, & 6. See <i>ZEM Programming</i> .
4	off	zone 1 remote	Provides supervised annunciator connection to remote alarm indicator.
3	off	silent walktest	Silences indicating circuits 1 & 2 during walktest mode. See <i>Zone Disconnect/Walktest</i> .
2	off	zone 1 waterflow*	Disables alarm disconnect switch. Signals cannot be silenced.
1	off	alarm verification	Two consecutive alarm input signals required for alarm output. See <i>Alarm Verification</i> .

* Do not program zone for waterflow in conjunction with walktest because the communicator or optional LEM module may transmit an alarm condition. In addition, the system alarm relay will be activated.

ZEM Programming

All programming selections are controlled by switches located in the front right center of the ZEM. Table 6 shows default (factory) programming along with a description of each feature.

Table 6. ZEM Programming Features

Switch #	Factory Position	Feature	Description
8	off	zones 3 & 5 waterflow*	Alarm disconnect switch enabled. Signals can be silenced.
7	off	zones 2 & 4 waterflow*	Alarm disconnect switch enabled. Signals can be silenced.
6	off	zone 2 supervisory	Fire alarm signal enabled. Yellow supervisory LED on 1500-BMB is disabled. See <i>Supervisory Functions</i> .
5	off	zone 2 supervisory	Fire alarm signal enabled. Yellow supervisory LED on 1500-BMB is disabled. See <i>Supervisory Functions</i> .
4	on	zone 2 supervisory	Fire alarm signal enabled. Yellow supervisory LED on 1500-BMB is disabled. See <i>Supervisory Functions</i> .
3	on	zone 2 supervisory	Fire alarm signal enabled. Yellow supervisory LED on 1500-BMB is disabled. See <i>Supervisory Functions</i> .
2	on	zone 3 & 5 Remote Annunciator	Connection to remote indicator not supervised.
1	on	zone 2 & 4 Remote Annunciator	Connection to remote indicator not supervised.

* Do not program zones for waterflow in conjunction with walktest because the communicator or optional LEM module may transmit an alarm condition. In addition, the system alarm relay will be activated.

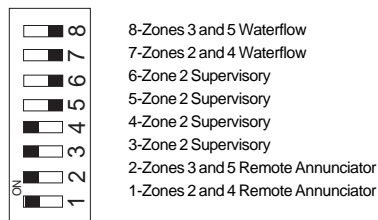

Figure 13. ZEM Default Settings

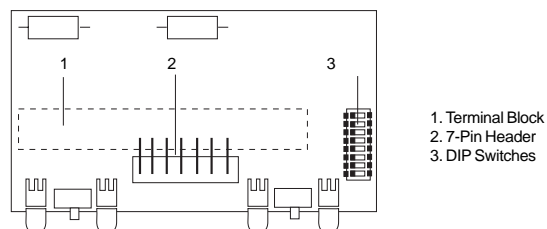

Figure 14. ZEM Programming Switches Location

Testing and System Checkout

Following installation and programming of the unit, a complete test of the entire system must be conducted to assure proper operation. NFPA 72, National Fire Alarm Code should serve as the guide. Follow the recommended procedures, restoring all switches and wiring to normal before proceeding to the next step.

Notify all building personnel and the fire department and monitoring facilities before and after system testing.

After testing all systems and restoring the panel to its normal operating condition, remove, and mount the 1500 Series Operating Instructions, Appendix C, in a visible position near the control unit. In a household fire warning system, test weekly. Disconnect the AC power source during testing. If after testing low battery conditions exists, replace the batteries.

Maintenance

Batteries

The 1500 Series control unit uses two sealed lead-acid batteries as the secondary power source. The batteries must be replaced if the Low Battery LED remains on for more than 48 hours (indicates one or more of the battery cells are dead or the batteries will not hold a charge). If the batteries are dead, replace with batteries of the same size and electrical rating, with a maximum size of 12V, 12 Amp hours and dimensions of 4" x 4" x 6" (10cm x 10cm x 15cm).

Note: When replacing batteries, always replace both batteries, even if only one appears dead. Typical battery life is 3 to 5 years, depending on usage. See the manufacturer's specifications for the particular battery used. The battery charging circuit drops out if the charge falls below 15 VDC at batteries.

Fuses

The fuse located in the lower left corner of the BMB is provided for overcurrent protection. The fuse can be tested with an ohmmeter or visually inspected. If the fuse is blown, replace with a type 3AG, 1 1/4" (3cm) x 1/4" (0.6cm), 6 Amp Fast Blow fuse.

Troubleshooting

Table 7 provides a quick reference troubleshooting guide that will aide in diagnosing and locating most system faults quickly and efficiently. If you cannot resolve the fault with the assistance of this guide, call Technical Support at 800.648.7424.

Table 7. Troubleshooting Guide

Trouble indicators	Possible cause	Corrective action
Zone 1-5 trouble LED System trouble LED Trouble sounder slow intermittent	End-of-line resistor value incorrect or missing	Meter circuit to verify proper resistance
	Loss of power to power supervision relay	Meter voltage on circuit
	Polarity reversal relay wired incorrectly	Check circuit diagram to confirm wiring
	Loose connection or broken wire	Check for opens in circuit
	Disconnect/Walktest switch not in normal position	Put Disconnect/Walktest switch in normal position
	Faulty waterflow switch	Repair or replace waterflow switch
	Initiating device missing from circuit	Check for any devices that may have been removed from the initiating circuit
	“Class A” wires crossed in circuit	Make sure polarity is observed completely through circuit
	“Class B” wires connected to wrong terminals	Make sure wires are connected to “Class B” terminals
	Incompatible two wire detector	Check UL compatibility listing to verify the detector is listed for use with the panel
Overcurrent or lightning damage	Check for burn marks or other signs of overcurrent damage. Return to factory for service. Replace board if traces are damaged.	
Supervisory trouble LED Rapid trouble beep Zone 2 alarm LED Remote annunciator zone 2	Zone 2 supervisory device tripped	Check initiating device on zone 2
System trouble LED Zone 2 trouble LED Rapid trouble beep	Open in zone 2 circuit	Check zone 2 for broken wires or opens in circuit
	Disconnect/Walktest switch not in normal position	Put Disconnect/Walktest switch in normal position
Low/No AC power System trouble LED Trouble sounder slow intermittent	Loss of AC (line voltage)	If line voltage is too low, upgrade or move to new circuit
	Low AC power Less than 94 VAC at transformer primary-no load Less than 102 VAC with maximum load Less than 22 VAC at transformer secondary-no load	If secondary shows less than 22 VAC replace transformer
	Damaged transformer or loose connection	Check for loose or broken connections
Low/No battery LED System trouble LED Trouble sounder slow intermittent	Battery low Less than 24 VDC	Replace batteries
	Battery missing or less than 20 VDC	Replace batteries
	Blown fuse	If fuse is blown, determine why fuse was blown, correct problem, and replace fuse
	Open in battery harness	If there is an open or break in the battery harness, replace it
Ground fault LED System trouble LED Trouble sounder slow intermittent	Ground on any circuit, other than alarm or trouble contacts	Remove one wire at a time until ground fault LED and system trouble LED goes out. Repair circuit causing fault condition.
	Ground in transformer	Remove AC input from board, if ground fault LED goes out, there is a ground in the transformer-replace transformer
Indicating 1-2 trouble LED System trouble LED	End-of-line resistor value incorrect or missing	Meter circuit to verify proper resistance
	Polarity reversed in circuit	Check circuit diagram to confirm wiring and polarity
	Loose connection or broken wire	Check for opens in circuit
	Indicating device missing from circuit	Check for any devices that may have been removed from the indicating circuit
	Style “Z” wires crossed in circuit	Make sure polarity is observed completely through circuit
	Style “Y” wire connected to wrong terminals	Make sure wires are connected to style “Y” terminals
	Overcurrent or lightning damage	Check for burn marks or other signs of overcurrent damage. Return to factory for service. Replace board if traces are damaged.
System trouble LED Trouble sounder slow intermittent (with no other indicators)	Bad ZEM connection	Check connector pins where ZEM connects to the BMB
	ZEM malfunction	Check for signs of damage to the BMB or ZEM
	BMB malfunction	Return to factory for service or replace boards.

Specifications

General

Operating temperature..... 0° to 49°C (32° to 120°F)

Housing

Type.....Steel with hinged/removable, locking door

Size.....14.0 in. x 14.0 in. x 4.5 in.(35.6cm x 35.6cm x 11.4cm)

Finish.....Red, sand textured, enamel

Weight..... 15 lbs. max. w/o battery

1500-BMB- Basic Master Board

Power

Input power.....120 VAC, 60Hz, 56 V A

Standby power..... 24 VDC

Auxiliary power output..... 24 VDC FWR, 1.0 A max.

.....(32.1 VDC max. - no load)

Note: Auxiliary power output supply is shared with power for indicating circuit. Consider total requirements.

$$(I_{aux} + I_{IND\#1} + I_{IND\#2} = 1.5 A)$$

Optional standby battery..... 24 Volt

Battery charger rate..... 700 mA max.

Battery charge voltage..... 29 V max.

Alarm initiating circuits

Number of circuits..... One - model 1501

Three - model 1503

Five - model 1505

Type..... Class A or B, Latched (Style B or D)

End-of-line..... 2.7 K Ohms, 1/2 Watt

Loop powered device current..... 2.0 mA

Alarm current..... 15 mA

Maximum current..... 60 mA

Maximum voltage..... 17 Volts

Normal circuit voltage..... 14.7 Volts

Minimum voltage..... 13.5 Volts

Maximum ripple voltage..... 500 Millivolts AC

Maximum line resistance.....100 Ohms(Compatibility Ident.C01)

Ohms(Compatibility, Ident.C01A)

Alarm indicating circuits

Number of circuits Two Class A or B (Style Y or Z)

Maximum current per circuit..... 1.0 Amps

Maximum total current 1.5 Amps

Output voltage 24 VDC, FWR

End-of-line 2.7 K Ohms, 1/2 Watt

Supplementary alarm/trouble contacts

System trouble 2.0 A @ 30 VDC resistive

System alarm 2.0 A @ 30 VDC resistive

Sounder output

Alarm.....Constant output

Fault -0.25 sec. on; 2.5 sec. off

Supervisory -0.25 sec. on; 0.25 sec. off

Remote indicator

Voltage 12 VDC

Current 15 mA max.

1500-ZEM - Zone Expander Module

Initiating circuits

Number of circuits Two

Type Class A or B, latched (Style B or D)

End-of-line..... 2.7 K Ohms, 1/2 Watt

Loop powered device current..... 2.0 mA

Alarm current 15 mA

Maximum current 60 mA

Maximum voltage 17 Volts

Normal circuit voltage 14.7 Volts

Minimum voltage 13.5 Volts

Maximum ripple voltage 500 Millivolts AC

Maximum line resistance

100 Ohms(Compatibility Ident. C01)

50 Ohms (Compatibility Ident. C01A)

Remote Indicator

Voltage 12 VDC

Current 15 mA max.

1500-LEM - Local Energy Module

Output characteristics

Standby 2 VDC (no load)

Alarm 24 VDC FWR

Trouble 0 VDC

Alarm current 320 mA max.

Standby current 1 mA

1500-ZRM-5 - Zone Relay Module

Output characteristics

Voltage 12 VDC

Standby current 0 mA per circuit

Alarm current 15 mA per circuit

Contact ratings 3 A @ 30 VAC/DC

1500-RA-5A - Remote Annunciator

Output Characteristics

Number of zones 5 alarm, 1 trouble

Voltage 12 VDC

Standby current 0 mA per circuit

Trouble current 50 mA

Alarm current 15 mA per circuit

Appendix A, Compatible Equipment

The equipment listed here is compatible with the ESL 1500 Series Fire Control Panel. Use **ONLY UL Listed compatible equipment with the 1500 Series to assure proper operation.** Should you have any questions about compatibility, call technical support at 800.648.7424.

Initiating Devices

Compatible Equipment:

- All UL Listed non-coded manual alarm stations and heat detectors, including ESL Series 103 and 104.
- Compatible indicating devices shown in Table 8.
- UL Listed two-wire smoke detectors shown in Table 9.
- UL Listed four-wire smoke detectors shown in Table 10.

Table 8. Compatible Indicating Devices

Manufacturer	Part Number
Amseco	SLB24-75C
Amseco	SLB24G-75C
Amseco	SMS1-3A
EST	G1(R)-HOV110
EST	G1(R)-HOV15
EST	G1(R)-HOV75
EST	G1(R)-V15
EST	G1(R)-V75
EST	G1(R)-HO
EST	G1(R)-H
EST	G1(R)-P
EST	G1M
EST	G1M-RM
Gentex	ST24-15/75WR
Gentex	GES24-15/75WR
Gentex	HS24-15/75WR
Gentex	GEC24-15/75WR
Gentex	HS24-110WR
Gentex	GEC24-110WR
System Sensor	S241575
System Sensor	S24110
System Sensor	P241575
System Sensor	P24110
System Sensor	SC241575
System Sensor	PC241575
System Sensor	SP2R241575
System Sensor	SP2R24110
System Sensor	MDL
Wheelock	NS-24MCW
Wheelock	NS4-24MCW
Wheelock	RSS-24MCW-FR
Wheelock	RSS-24MCW-FW
Wheelock	RSSP-24MCW-FR
Wheelock	ET70-24MCW-FR
Wheelock	ET70-R
Wheelock	MPS-100
Wheelock	MPS-400X
Wheelock	SM-12/24-R
Wheelock	DSM-12/24-R

Table 9. Two-Wire Smoke Detector Compatibility

Detector Series	Detector Models	Maximum Line Resistance (Ohms)	Control Unit Compatibility Identifier	Compatiblity Identifier	Number per Circuit
ESL 400 Series Self-Diagnostic	429C, 429CT	100	C01	S10A	20
	429CRT, 429CST	100	C01	S11A	20
ESL 500 Series and ESL 500N Series	521B, 521NB	100	C01	DIP SW 1 ON S09A DIP SW 1 OFF S10A	20
	521BXT, 521NBXT	100	C01	DIP SW 1 ON S09A DIP SW 1 OFF S10A	20
	521CRXT, 521NCRXT	100	C01	S11A	20
	521NCSXT	100	C01	S10A	20
	521NCSRXT	100	C01	S11A	20
ESL 700 Series (Heads) With 700 Series Bases	711U, 711UT, 712U, 713-5U, 721UT,741UT	100	C01	S10A	20
	702U, 702E, 702U mounting base	100	C01	S00	NA
	731U 4 wire	100	C01	S11A	20
	702RE, 702RU mounting base	100	C01	S00	NA

Table 10. Four-Wire Smoke Detector Compatibility

ESL Series	Suffix Letters
449	C, CT, CRT, CST, CSRT, CSRH, and CTE
541	C, CXT, NB, NBXT, NCSRH, NCRXT, NCXTE NCSXT, NCSRXT, NCSXTE
741UT with 702U base	U

Appendix B

ESL 1500 Series Standby Battery Power Worksheet

1500 Series System Components	Standby Current Per Device	Total Standby Current	Alarm Current Per Device	Total Alarm Current
1500-BMB (Zone 1)		100 mA		200 mA
Indicating Circuit #1		5 mA	1 Amp = 1000 mA	mA
Indicating Circuit #2		5 mA	1 Amp = 1000 mA	mA
Auxiliary System Power		mA	1 Amp = 1000 mA	mA
1500-ZEM (Zone 2)	8 mA	mA	70 mA	mA
1500-ZEM (Zone 3)	8 mA	mA	70 mA	mA
1500-ZEM (Zone 4)	8 mA	mA	70 mA	mA
1500-ZEM (Zone 5)	8 mA	mA	70 mA	mA
1500-LEM	1 mA		320 mA	
1500-ZRM-5	0 mA		75 mA	
1500-RA5A	0 mA	mA	75 mA	mA
		mA		mA
		mA		mA
		mA		mA
		mA		mA
Total Current Requirements		mA		mA

mA X .001 Amp/mA X _____ hours = _____ Ah **Standby AMP - Hours**

Total Standby Current	Conversion Factor	Required # of Hours in Standby
-----------------------	-------------------	--------------------------------

+

mA X .001 Amp/mA X _____ minutes X .0167 hour/min = _____ Ah **Alarm Amp - Hours**

Total Alarm Current	Conversion Factor	Required # of Minutes in Alarm	Conversion Factor
---------------------	-------------------	--------------------------------	-------------------

=

Total Standby Battery Power = _____ Ah X 1.15 = _____ Ah

Examples of 12 Ah Maximum Loading

	24 hour standby 15 minute alarm	60 hour standby 15 minute alarm
Maximum standby current (mA)	416	167
Maximum alarm current (mA)	1500	1500
Maximum battery capacity (Ah)	12	12

Battery Capacity Derating Coefficient	12 Ah Maximum
---------------------------------------	---------------

Appendix C

1500 Series Operating Instructions

Refer to the 1500 Series Installation Manual for more information

Normal Standby Condition

- Green “AX POWER” LED “ON”
- All other LEDs “OFF”
- All switches in “NORMAL” position

Alarm Condition

- Red local zone alarm LED “ON”
- Integral sounder sounds a steady signal
- Auxiliary alarm relay contacts transfer and latch
- Supervised remote annunciator indication is “ON”
- Indicating circuits turn “ON”

Alarm Disconnect Switch Operated (Prior to Alarm Condition) For Maintenance Use Only

- Disconnects local zone alarm from the auxiliary alarm relay
- Disconnects local zone alarm from the alarm indicating circuits
- Red local zone alarm LED turns “ON”
- Supervised remote annunciator indication is “ON”
- Alarm signal from any other zone is **not** affected

Alarm Disconnect Switch Operated (After Alarm Condition) For Maintenance Use Only

- Auxiliary alarm relay contacts remain latched
- Alarm indicating circuits are turned “OFF”
- Red local zone alarm LED remains “ON”
- Supervised remote annunciator indication remains “ON”
- Alarm signal from any other zone is **not** affected

Reset Switch Operated

- Initiating circuit power removed (smoke detectors reset)
- Indicating circuits turn “OFF”
- Integral sounder sounds steady signal
- Auxiliary alarm relay is reset

Reset Switch Released

- System restored to normal unless initiating devices are **not** reset

Trouble Condition

- Yellow system trouble LED is “ON”
- Yellow diagnostic LED is “ON”
- Integral sounder sounds a slow intermittent signal
- System trouble relay contacts transfer

Sounder Silence Switch Operated

- Integral sounder is “OFF” when system trouble is present
- Integral sounder is “ON” when system is in normal standby condition
- System trouble relay contacts are **not** affected
- Will **not** silence supervisory alarm, supervisory trouble, or system alarm signals

Supervisory Alarm Signal

- Integral sounder sounds a fast intermittent signal
- Zone #2 red local zone alarm LED is “ON”
- Zone #2 supervised remote annunciator indication is “ON”
- Auxiliary alarm relay contact do **not** transfer
- Indicating circuits are **not** activated
- Yellow supervisory LED is “ON”

Supervisory Trouble Signal

- Indicating sounder sounds a fast intermittent signal
- Zone #2 yellow local zone trouble LED is “ON”
- System trouble relay contacts transfer
- Yellow supervisory LED is “ON”

Remote Test (Fire Drill)

- Indicating circuits turn “ON”
- Integral sounder sounds a slow intermittent signal
- Auxiliary alarm relay contacts do **not** transfer
- LEM module does **not** transmit
- Keying the test switch will pulse the indicating circuits

Testing - Disconnect the AC power source during testing. If, after testing, a low battery condition exists, replace the batteries.

“This equipment should be installed in accordance with the National Fire Protection Association’s Standard 72 (NFPA, Batterymarch park, Quincy, MA 02269). Printed information describing proper installation, operation, testing, maintenance, evacuation planning, and repair service is to be provided with this equipment.”

Warning:

Owner’s instruction notices: “Not to be removed by anyone except occupant.”

For Service Contact:

GE Security, 12345 SW Leveton Dr., Tualatin, OR 97062 Sales: 800.547.2556 Technical Support: 800.648.7424

Remove this page, frame, and mount adjacent to control unit.



GE Security

GE Security
12345 SW Leveton Drive
Tualatin, OR 97062
503-692-4052
USA & Canada: 800-547-2556

Tech Support
800-648-7424
FaxBack: 800-483-2495
www.GESecurity.com

12603 Rev. J 04/04
64812687 Rev. J