



MPE™-S2 MA Series Mic Pre-Amp Module

DESCRIPTION:

The MPE-S2 is an electronically balanced microphone pre-amp module for the MMA Series of Peavey Architectural Acoustics mixer/amplifiers. It has screwdriver-adjustable pre-amp gain and low-cut filter, Phoenix-style connector for permanent installation wiring, switchable phantom power, three muting options, and an inverting mute function that mutes the master mic when no signal is present. The electronic balancing affords a good Common Mode Rejection Ratio (CMRR) at a low cost for short to medium mic-level cable runs. For extremely long runs, use the MPT Series of transformer-coupled mic pre-amp modules.

FEATURES:

- Modular construction
- Economical electronically balanced input circuitry
- Screwdriver adjustable pre-amp gain
- Screwdriver adjustable low-cut filter
- Phoenix-style connector
- Switchable 24 VDC phantom power
- Mute master function selectable between two mute buses
- Mute slave function selectable between two mute buses
- Mute slave inversion function to mute a master mic with no signal present

APPLICATIONS:

- Retail outlets
- Auditoriums
- Gymnasiums
- Paging systems
- Foreground music systems
- Background music systems
- Hotel meeting rooms
- Houses of worship
- Conference centers
- Civic centers

AUDIO SPECIFICATIONS

Frequency Response:

20 Hz – 20 kHz, +0/-1 dB

Total Harmonic Distortion:

</= 0.05% @ 1 kHz

Equivalent Input Noise (EIN):

</= -128 dBu

Input CMRR (Common Mode Rejection Ratio):

>60 dB 20 Hz — 20 kHz

Range of Input Level for Normal Out (100 mV):

(0.25 mV to 100 mV) MIC input

(2.5 mV to 1 V) Line input

Minimum Source Impedance:

150 Ω

Input Impedance:

2.2 kΩ

CONTROL SPECIFICATIONS

Pre-amp Gain Control:

0 dB to 53 dB (screwdriver adjustable)

Low-cut control:

Adjustable shelving type, low-cut filter with a corner frequency of 125 Hz

Mute Functions:

- Mute master select for mute bus 1 and mute bus 2 (PC board jumper)
- Mute slave select for mute bus 1 and mute bus 2 (PC board jumper)
- Mute slave inversion is used to reverse the slave operation of the module (see Inverting Slave Mode on the back page).

Phantom Power:

Switchable 24 VDC (PC board jumper)

GENERAL SPECIFICATIONS

Dimensions:

3.07" H x 1.38" W x 3.46" D

(77.97 mm x 35.05 mm x 87.88 mm)

Net Weight:

2.6 oz. (4.55 g.)

Power consumption:

336 mW (14 mA @ 24 VDC) supplied by the MMA mixer/amplifier

Finish:

Grey powder-coat painted steel on mounting panel

MPE S2 Block Diagram

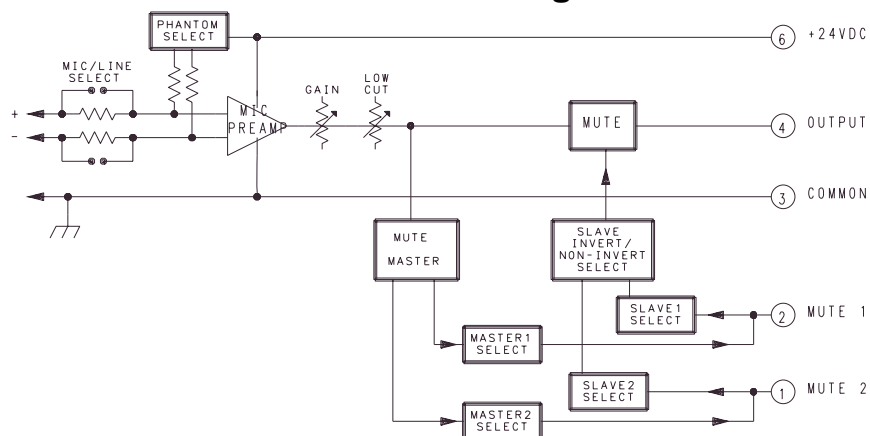

Front Panel:

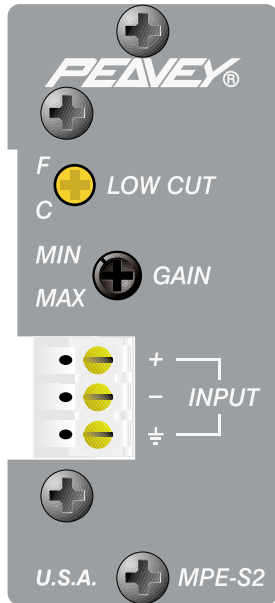

Call-Outs for MPE-S2 Jumper Settings:

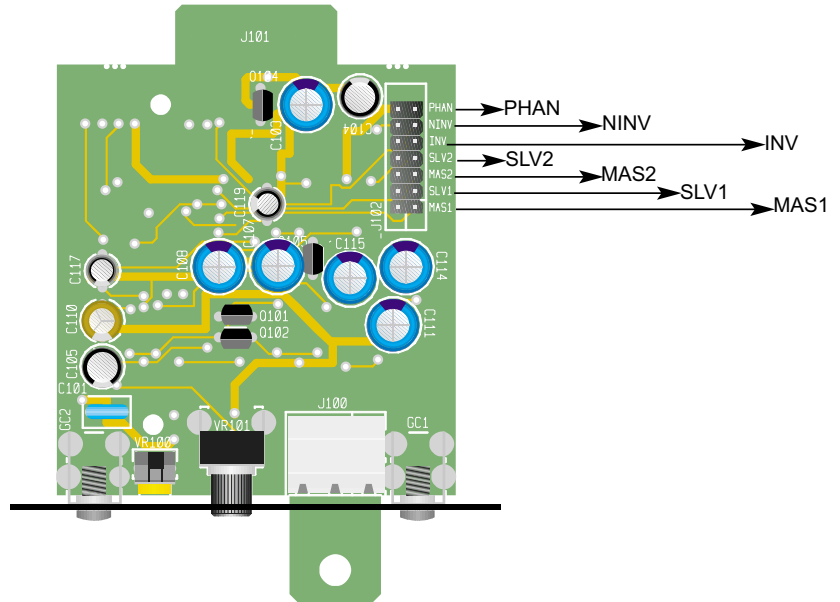

MUTE FEATURES:

An important feature of the MMA Series of mixers/package amps is simultaneous operation of two separate mute buses. The MPE-S2 has been designed to take full advantage of both mute buses with a wide variety of programming options.

PHAN (Phantom Power):

With jumper means 24 VDC at both the + and - signal input terminals.

MASTER:

The MPE-S2 can be "master" on Mute 1 and/or Mute 2. Being assigned "master" means that the MPE-S2 would have muting control of the selected bus. For example, three modules used for music or speech are assigned as slaves on the Mute 1 bus. The MPE-S2 is assigned as master on Mute 1 as an emergency signal source. When the emergency signal is activated, the slave modules are muted and only the MPE-S2 is heard. To assign the MPE-S2 as master on Mute 1 or Mute 2, simply install the supplied jumper on the two pins labeled MAS 1 or MAS 2.

SLAVE:

The MPE-S2 can be "slave" on Mute 1 and/or Mute 2. Being assigned "slave" means that any signal from a master source on the corresponding bus would mute the MPE-S2. To assign the MPE-S2 as a slave on Mute 1 and/or Mute 2, simply install a supplied jumper on the two pin labeled SLV 1 and/or SLV 2. The MPE-S2 slave function can operate in one of the two modes: as a normal non-inverting slave or as an inverting slave.

Non-Inverting Slave:

This is the normal slave mode of the MPE-S2. When a jumper is on this position's pins, a signal from a master source on the selected mute bus will mute the MPE-S2. Install a jumper on the two pins labeled NINV to activate this mode for either mute bus (or both, if both are selected).

Inverting Slave Mode*:

A new feature of the MPE-S2 is its ability to invert the slave operation. This simply means that instead of muting when a mute signal is on the bus, the module is muted when the mute signal is absent. This can be used to set up a MMA system for automatic or push-button activated paging.

Automatic: To use the module in this way, it must be assigned as a master and a slave on the same bus. Other modules on the bus must be assigned as non-inverting slaves. In this mode, the master module used to page would normally be muted, while all other modules would be un-muted. When signal is applied to the master module, it un-mutes and all of the other slave modules would mute.

Push-Button: In the push-button mode, the settings are identical to those of the automatic mode with two exceptions: (1) The module does not have to be assigned as a master to the bus, and (2) A push-button would be wired across the external mute terminal of the mixer/package amp to ground. Rather than the signal source triggering the mute and page, the push-button does the activation. This would be a more reliable method if a soft-talker were using the system. ***NOTE:** The module must be assigned as either inverting or non-inverting for proper operation even if it is not assigned as a slave.

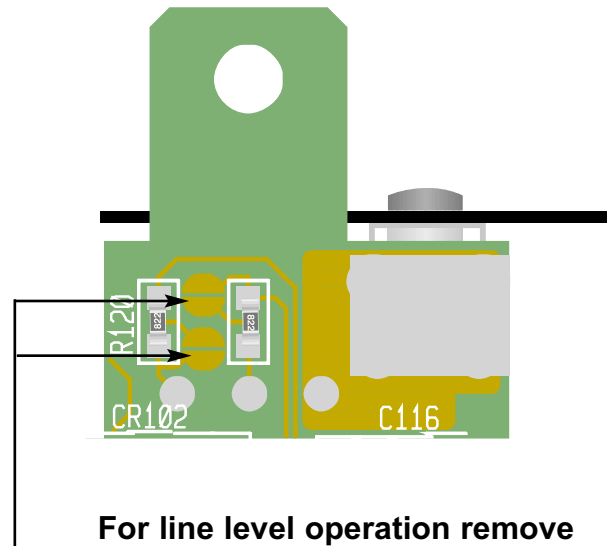

For line level operation remove solder from the two pads.



Features and specifications subject to change without notice.

Peavey Electronics Corporation • 711 A Street • Meridian • MS • 39301
(601) 483-5365 • FAX (601) 486-1278 • www.aa.peavey.com



80304655

Printed in the U.S.A. 4/00