



REZNOR *Thomas & Betts*

Model Series XE, RGB, CRGB, RPB Packaged Duct Furnace Assemblies

INSTALLATION FORM RZ-NA 403 (Version B)

Obsoletes Form RGM 403 (Version A)

APPLIES TO: **Installation/Operation/Service**

Table of Contents	Paragraph No.	Page No.
Installation and Operation	1-29	1-28
Check Installation and Start-Up	30	29-30
Optional Accessories	31-36	30-40
Service/Maintenance/Troubleshooting	37-40	41-44

Index by Page Number

Adjusting Blower Speed	23	Disconnect Switch	16	Optional Equipment/Accessories	30
Optional Air Flow Proving Switch	23	Duct Connections	14	100% Outside Air Hood	30
Belts	23	Optional Ductstat	25	Outside Air Hood for 30% Outside Air Opening	31
Blocked Vent Switch (Indoor)	24	Electrical Supply and Connections	16	Pilot and Ignition Systems	27
Blower Motors	23	Optional Electronic Modulation	25	Reverse Flow, Limit Control	24
Blower Rotation	23	Optional Evaporative Cooling Module ..	31	Roof Curb Assembly and Installation	9
Burner Air Adjustment	28	Fan Control	23	SERVICE	41
Burner Rack Removal	41	Optional Dirty Filter Switch	37	Optional 4-foot Stack Extension	13
Burners	28	Optional Filter Rack and Filters	36	Start-Up	29
Carryover System	28	Filter Arrangements	36	Suspending Furnaces	8
Check Installation and Start-Up	29	Gas Piping and Pressures	14	Troubleshooting (General)	42
Chlorine	7	GENERAL	1	Troubleshooting an Optional Evaporative Cooling Module	43
Cleaning Pilot and Main Burners	41	HAZARD INTENSITY LEVELS	2	Optional Two-Stage Operation	24
Cleaning the Heat Exchanger	41	Optional High Ambient Limit Control	23	Uncracking	2
Clearances	7	Ignition Controller	28	Valve	24
Combustion Air Requirements	7	Installation Codes	2	Vent Cap Installation	12
Condensate Drain	13	Limit Control	23	Optional Power Venting	12
Control Locations	17	Location of Standard and Optional Controls	17	Venting	10
Optional Cooling Coil Cabinet	6, 38	MAINTENANCE	41	Optional Vertical Flue Discharge	13
Optional Dampers and Controls	35	Optional Mechanical Modulation	25	Warranty	2
Dimensions	3	Mounting Furnaces (Indoor)	8	WIRING DIAGRAMS	18-22
Optional Direct Digital Control Interface ..	27	Mounting Outdoor Models	8		
Discharge Damper Connections	39				

Service REFERENCES: Replacement Parts for Outdoor Units, **Form RZ-NA 707**
Replacement Parts for Indoor Units, **Form RZ-NA 705**

FOR YOUR SAFETY

If you smell gas:

1. Open windows.
2. Don't touch electrical switches.
3. Extinguish any open flame.
4. Immediately call your gas supplier.

WARNING: Gas-fired appliances are not designed for use in hazardous atmospheres containing flammable vapors or combustible dust, in atmospheres containing chlorinated or halogenated hydrocarbons, or in applications with airborne silicone substances. See Hazard Levels, Page 2.

WARNING: Improper installation, adjustment, alteration, service, or maintenance can cause property damage, injury or death. Read the installation, operation, and maintenance instructions thoroughly before installing or servicing this equipment.

FOR YOUR SAFETY

The use and storage of gasoline or other flammable vapors and liquids in open containers in the vicinity of this appliance is hazardous.

GENERAL

Installation should be done by a qualified agency in accordance with the instructions in this manual and in compliance with all codes and requirements of authorities having jurisdiction. The instructions in this manual apply to the packaged systems listed below.

Model Series Designation	Characteristics			
	Installation	Vent	CFM	Thermal Efficiency
XE	Indoor	Gravity	Standard	80%
HXE			High	
RGB	Outdoor		Standard	78%
CRGB			Standard	80%
HRGB			High	78%
HCRGB			High	80%
RPB		Power	Standard	80%
HRPB	High			

HAZARD INTENSITY LEVELS

- 1. DANGER: Failure to comply will result in severe personal injury or death and/or property damage.**
- 2. WARNING: Failure to comply could result in severe personal injury or death and/or property damage.**
- 3. CAUTION: Failure to comply could result in minor personal injury and/or property damage.**

1. Approval and Installation Codes

The models covered in this manual are design certified or approved duct furnaces that are factory assembled with air handling components, creating a unified packaged furnace/blower system. The packaged systems are design-certified to ANSI and CGA Standards by the Canadian Standards Association for installation in the United States and Canada. The furnaces are approved for use with either natural or propane gas. The type of gas for which the furnace is equipped and the correct firing rate are shown on the rating plate attached to the unit. Electrical characteristics are shown on both the motor nameplate and the unit rating plate. These units must be installed in accordance with local building codes. In the absence of local codes, in the United States, the unit must be installed in accordance with the National Fuel Gas Code (latest edition). A Canadian installation must be in accordance with the CAN/CGA B149.1 and B149.2 Installation Code for Gas Burning Appliances and Equipment. These codes are available from CSA Information Services, 1-800-463-6727. Local authorities having jurisdiction should be consulted before installation is made to verify local codes and installation procedure requirements.

Special Installations (Aircraft Hangars/Garages)

Installations in aircraft hangars should be in accordance with ANSI/NFPA No. 409 (latest edition), Standard for Aircraft Hangars; in public garages in accordance with ANSI/NFPA No. 88A (latest edition), Standard for Parking Structures; and for repair garages in accordance with ANSI/NFPA No. 88B (latest edition), Standard for Repair Garages. ANSI/NFPA-88 (latest edition) specifies overhead heaters must be installed at least eight feet above the floor. In Canada, installations in aircraft hangars should be in accordance with the requirements of the enforcing authorities, and in public garages in accordance with CAN/CGA B149 codes.

WARNING: To ensure safety, follow the lighting instructions located on the outlet box cover plate in the heater section of the packaged furnace assembly.

2. Warranty

Refer to limited warranty information on the warranty card in the "Owner's Envelope".

WARRANTY: Warranty is void if.....

- a. Packaged furnaces are used in atmospheres containing flammable vapors or atmospheres containing chlorinated or halogenated hydrocarbons or any contaminant (silicone, aluminium oxide, etc.) that adheres to the spark ignition flame sensing probe on furnaces equipped with optional spark pilot.
- b. Wiring is not in accordance with the diagram furnished with the heater.
- c. Unit is installed without proper clearances to combustible materials or without proper ventilation and air for combustion. (See Paragraphs 5 and 6.)
- d. Furnace air throughput is not adjusted within the range specified on the rating plate.

3. Uncrating and Preparation

This furnace was test operated and inspected at the factory prior to crating and was in operating condition. If the equipment has incurred any damage in shipment, document the damage with the carrier and contact your Reznor distributor.

Check the rating plate for the gas specifications and electrical characteristics of the furnace to be sure that they are compatible with the gas and electric supplies at the installation site. Read this booklet and become familiar with the installation requirements of your particular model. If you do not have knowledge of local requirements, check with the local gas company or any other local agencies who might have requirements concerning this installation. Before beginning, make preparations for necessary supplies, tools, and manpower.

Check to see if there are any field-installed options that need to be assembled to the furnace prior to installation.

Option Parts -- Some gas control options will have parts either shipped loose with the heater or shipped separately. If your unit is equipped with any of the following gas control options, be sure these parts are available at the job site.

Heating -- Gas Control Option	Option AG7 Thermostat, P/N 48033
Makeup Air -- Gas Control Options	Option AG3, AG6, AG8 or AG13 Control Switch, P/N 29054
(If an optional remote console is ordered, the control switch is mounted on the console.)	Option AG9 Remote Temperature Selector, P/N 48042 Control Switch, P/N 29054
	Option AG15 Remote Temperature Selector, P/N 115848 Stage Adder Module, P/N 115849 Control Switch, P/N 29054
	Option AG16 Remote Temperature Selector, P/N 115848 Stage Adder Module, P/N 115849 Remote Display Module, P/N 115852 Control Switch, P/N 29054
	Option AG39 Remote Temperature Selector, P/N 174849

Other shipped-separate options could include a roof curb, a cooling coil cabinet, a gas shutoff valve, a condensate drain fitting, a thermostat, a different control switch, a power venter, a remote console, a manual fan switch, a vertical vent terminal, a gas supply regulator, a screened outside air hood, or a disconnect switch.

4. Dimensions

Figure 1A - Dimensions (inches and mm) of Indoor/Gravity Vented Model

Dimensions of Model (H)XE with Standard Blower Cabinet (Standard blower cabinet has "full open" end and will not accommodate dampers. An optional cabinet is available with a smaller horizontal inlet that will accommodate dampers; see dimensional drawing below. An optional bottom inlet will also accommodate dampers.)

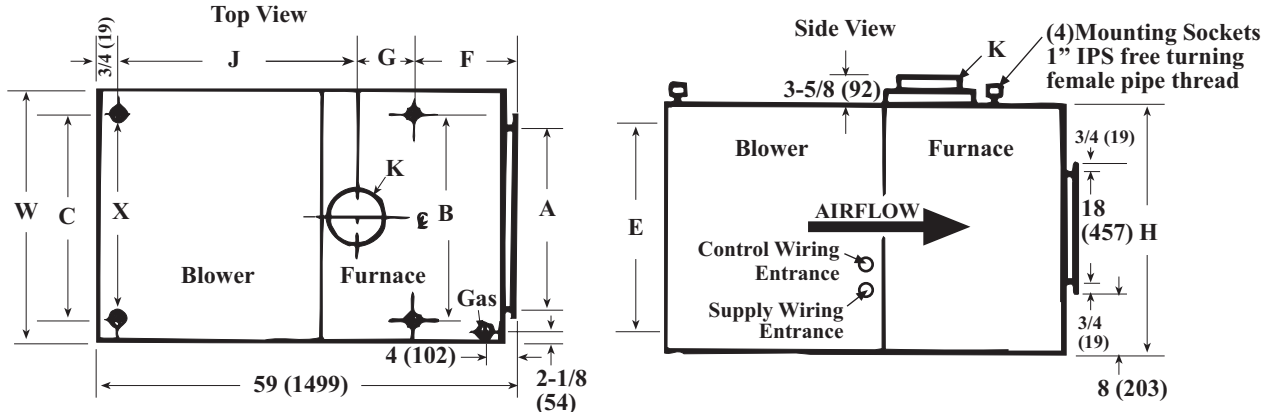

Dimensions of Model (H)XE with Optional Blower Cabinet (Optional blower cabinet has a horizontal inlet that will accommodate dampers. The cabinet also has a bottom inlet that is shipped with a cap; the bottom inlet will accommodate dampers.)

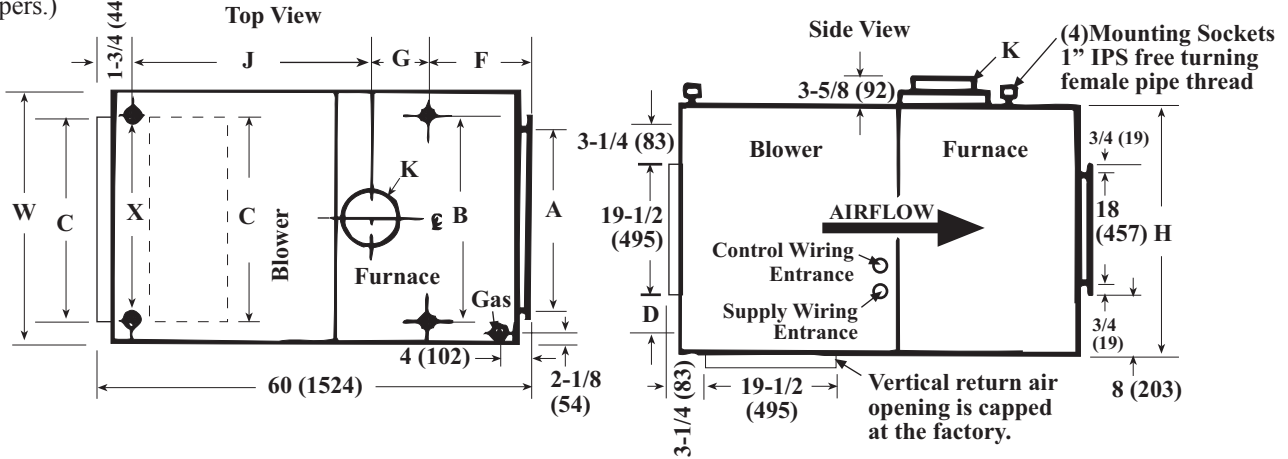

Dimension Key:		C x E = Return Air Opening with Standard Cabinet
A x 18" (457mm) = Discharge Opening		C x 19-1/2" (495mm) = Return Air Openings with Optional Cabinet
B = Hanger Centerline - Furnace Section		X = Hanger Centerline - Standard and Optional Blower Cabinet

Dimensions (inches and mm) - Gravity-Vented/Indoor Models

Size		A	B	C	D	E	F	Gas Connection		G	H	J	K	W	X
								Natural	Propane						
75	inches	12-1/2	13-1/2	17-3/8	9-1/2	27-3/4	18	1/2	1/2	3-3/4	32-1/4	36-1/2	5 Rd	22	16-1/4
	mm	318	343	441	241	705	457	13	13	95	819	927	127 Rd	559	413
100	inches	12-1/2	13-1/2	17-3/8	9-1/2	27-3/4	18	1/2	1/2	3-3/4	32-1/4	36-1/2	6 Rd	22	16-1/4
	mm	318	343	441	241	705	457	13	13	95	819	927	152 Rd	559	413
125	inches	15-1/4	16-1/4	17-3/8	9-1/2	27-3/4	18	1/2	1/2	3-3/4	32-1/4	36-1/2	7 Ov	22	16-1/4
	mm	387	413	441	241	705	457	13	13	95	819	927	178 Ov	559	413
150,	inches	20-3/4	21-3/4	23	9-1/2	27-3/4	19-3/8	1/2	1/2	2-3/8	32-1/4	36-1/2	8 Ov	27-1/2	21-3/4
	mm	527	552	584	241	705	492	13	13	60	819	927	203 Ov	699	552
200,	inches	26-1/4	27-1/4	28-3/8	12-1/2	30-3/4	18	1/2	1/2	2-1/4	35-1/4	38	8 Rd	33	27-1/4
	mm	667	692	721	318	781	457	13	13	57	895	965	203 Rd	838	692
250	inches	34-1/2	35-1/2	36-5/8	12-1/2	30-3/4	18	1/2	1/2	2-1/4	35-1/4	38	10 Ov	41-1/4	35-1/2
	mm	876	902	930	318	781	457	13	13	57	895	965	254 Ov	1048	902
300	inches	34-1/2	35-1/2	36-5/8	12-1/2	30-3/4	18	3/4	1/2	2-1/4	35-1/4	38	10 Ov	41-1/4	35-1/2
	mm	876	902	930	318	781	457	19	13	57	895	965	254 Ov	1048	902
350	inches	40	41	42-1/8	12-1/2	30-3/4	19-3/8	3/4	1/2	7/8	35-1/4	38	12 Ov	46-3/4	41
	mm	1016	1041	1070	318	781	492	19	13	22	895	965	305 Ov	1187	1041
400	inches	45-1/2	46-1/2	47-5/8	12-1/2	30-3/4	18	3/4	1/2	2-1/4	35-1/4	38	12 Ov	52-1/4	46-1/2
	mm	1156	1181	1210	318	781	457	19	13	57	895	965	305 Ov	1327	1181

4. Dimensions (cont'd)

Figure 1B - Dimensions, Outdoor/Gravity- Vented Model Series RGB	Model	Size		A	B	C	D	Vent Cap			Gas Connection	
								I.D.	Height	Extension	Natural	Propane
(H)RGB, (H)CRGB	75, 100	inches	28-5/8	17-3/8	25-7/8	12-1/2	6	9	None	1/2	1/2	
		mm	727	441	657	318	152	229	None	13	13	
	125	inches	28-5/8	17-3/8	25-7/8	15-1/4	8	11-1/2	None	1/2	1/2	
		mm	727	441	657	387	203	292	None	13	13	
	150, 175	inches	34-1/8	22-7/8	31-3/8	20-3/4	8	11-1/2	None	1/2	1/2	
		mm	867	581	797	527	203	292	None	13	13	
	200, 225	inches	39-5/8	28-3/8	36-7/8	26-1/4	10	15	None	1/2	1/2	
		mm	1006	721	937	667	254	381	None	13	13	
	250	inches	47-7/8	36-5/8	45-1/8	34-1/2	10	15	None	1/2	1/2	
		mm	1216	930	1146	876	254	381	None	13	13	
	(H)RGB	300	inches	47-7/8	36-5/8	45-1/8	34-1/2	12	14-1/8 plus	12	3/4	1/2
			mm	1216	930	1146	876	305	359 plus	305	19	13
(H)CRGB	300	inches	47-7/8	36-5/8	45-1/8	34-1/2	10	15	None	3/4	1/2	
		mm	1216	930	1146	876	254	381	None	19	13	
(H)RGB, (H)CRGB	350	inches	53-3/8	42-1/8	50-5/8	40	12	14-1/8 plus	12	3/4	1/2	
		mm	1362	1070	1286	1016	305	359	305	19	13	
(H)RGB, (H)CRGB	400	inches	58-7/8	47-5/8	56-1/8	45-1/2	12	14-1/8 plus	12	3/4	1/2	
		mm	1470	1210	1426	1156	305	359	305	19	13	
Air Opening Dimensions	Standard Horizontal Air Inlet									19-1/2 (495) x B		
	Optional Return Air Opening (bottom)									19-1/2 (495) x B		
	Standard Horizontal Discharge Air Opening									18 (457) x D		
	Optional Vertical Discharge Air Opening (Option AQ5 or AQ8 Downturn Plenum****)									19-1/2 (495) x B		

**** for downturn plenum with cooling coil cabinet, see page 6.

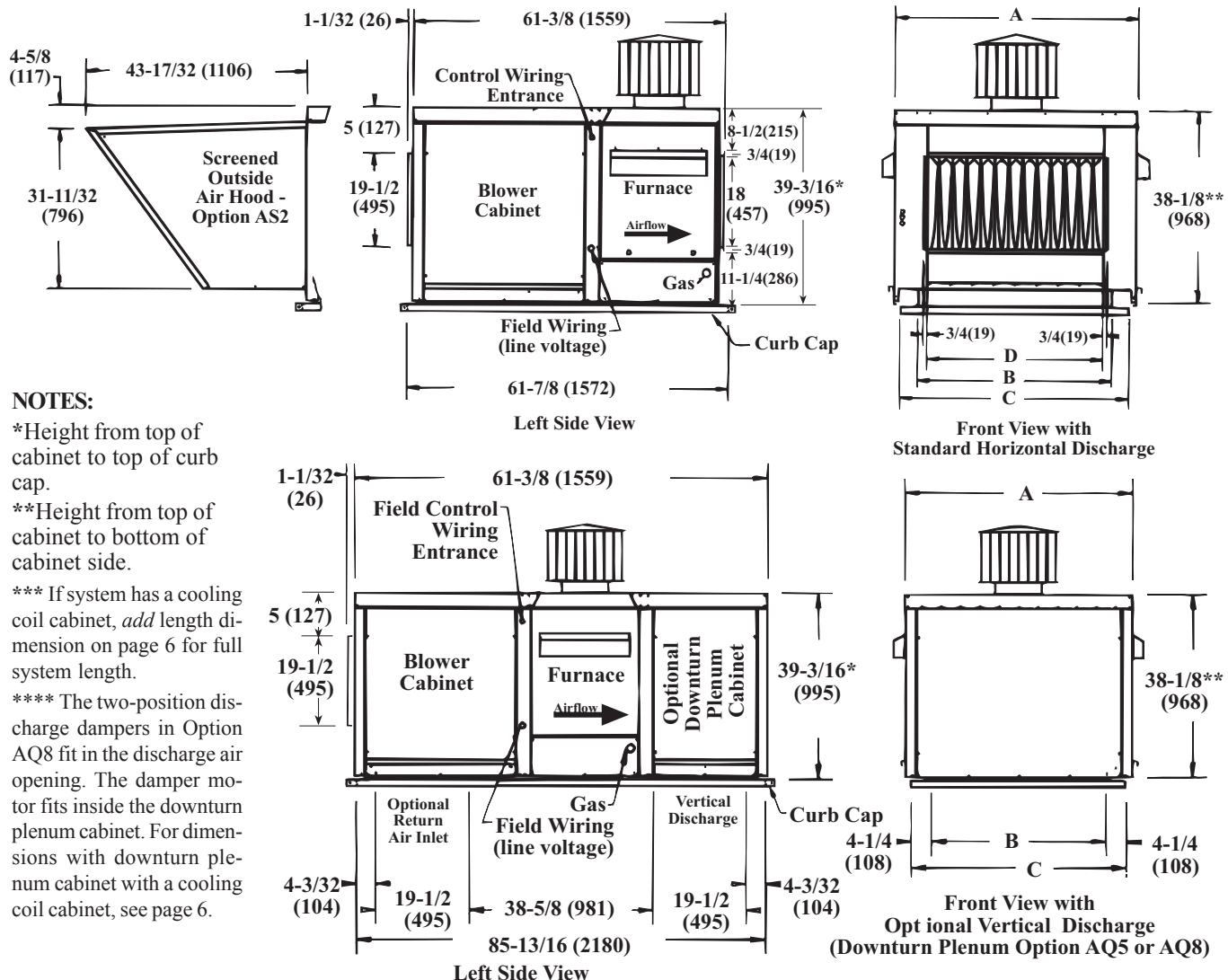

NOTES:

*Height from top of cabinet to top of curb cap.

**Height from top of cabinet to bottom of cabinet side.

*** If system has a cooling coil cabinet, *add* length dimension on page 6 for full system length.

**** The two-position discharge dampers in Option AQ8 fit in the discharge air opening. The damper motor fits inside the downturn plenum cabinet. For dimensions with downturn plenum cabinet with a cooling coil cabinet, see page 6.

Figure 1C - Dimensions, Outdoor/ Power-Vented Model Series RPB

Model	Size		A	B	C	D	Gas Connection	
							Natural	Propane
(H)-RPB	125	inches	28-5/8	17-3/8	25-7/8	15-1/4	1/2	1/2
		mm	727	441	657	387	13	13
	150, 175	inches	34-1/8	22-7/8	31-3/8	20-3/4	1/2	1/2
		mm	867	581	797	527	13	13
	200, 225	inches	39-5/8	28-3/8	36-7/8	26-1/4	1/2	1/2
		mm	1006	721	937	667	13	13
	250	inches	47-7/8	36-5/8	45-1/8	34-1/2	1/2	1/2
		mm	1216	930	1146	876	13	13
	300	inches	47-7/8	36-5/8	45-1/8	34-1/2	3/4	1/2
		mm	1216	930	1146	876	19	13
	350	inches	53-3/8	42-1/8	50-5/8	40	3/4	1/2
		mm	1362	1070	1286	1016	19	13
	400	inches	58-7/8	47-5/8	56-1/8	45-1/2	3/4	1/2
		mm	1470	1210	1426	1156	19	13

Air Openings:	Dimensions
Standard Horizontal Air Inlet	19-1/2 (495) x B
Optional Return Air Opening (bottom)	19-1/2 (495) x B
Standard Horizontal Discharge Air Opening	18 (457) x D
Optional Vertical Discharge Air Opening (with Option AQ5 or AQ8 Downturn Plenum****)	19-1/2 (495) x B

****for downturn plenum with cooling coil cabinet, see page 6.

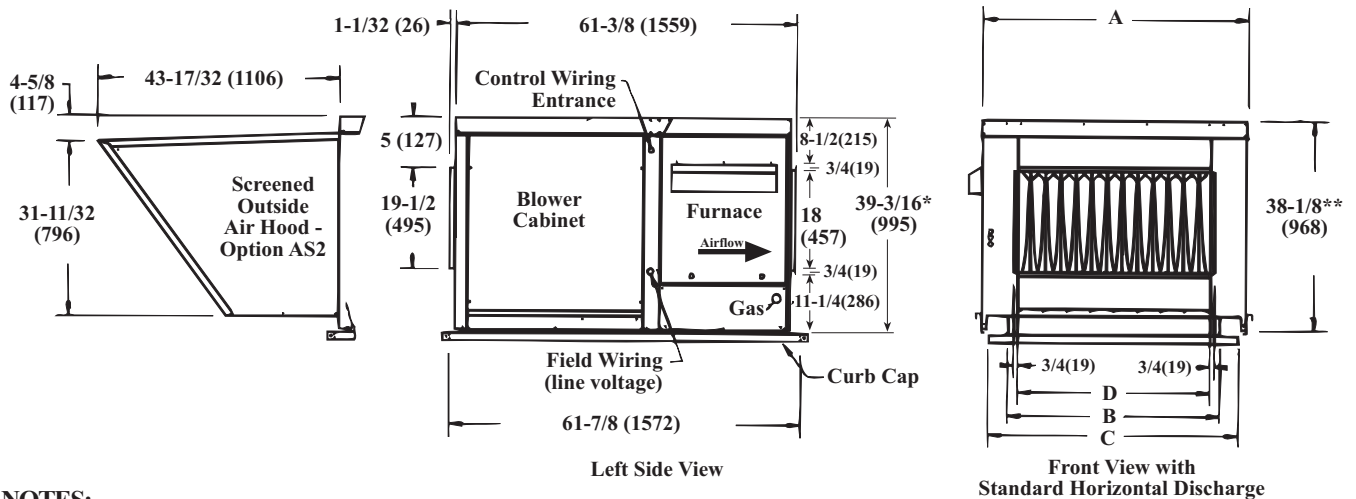

NOTES:

*Height from top of cabinet to top of curb cap.

**Height from top of cabinet to bottom of cabinet side.

*** If system has a cooling coil cabinet, *add* length dimension on page 6 for full system length.

**** The two-position discharge dampers in Option AQ8 fit in the discharge air opening. The damper motor fits inside the downturn plenum cabinet. For dimensions with downturn plenum cabinet with a cooling coil cabinet, see page 6.

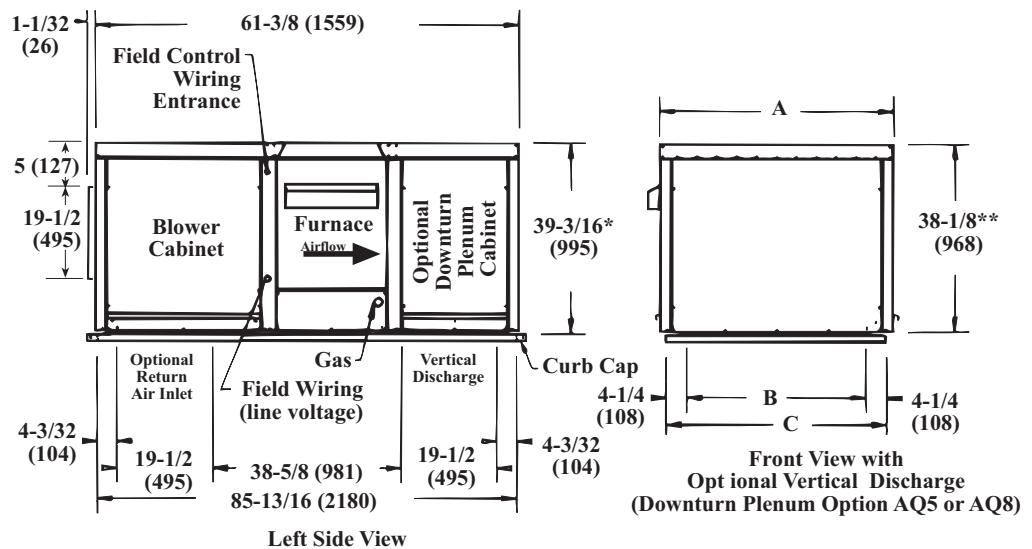

4. Dimensions (cont'd)

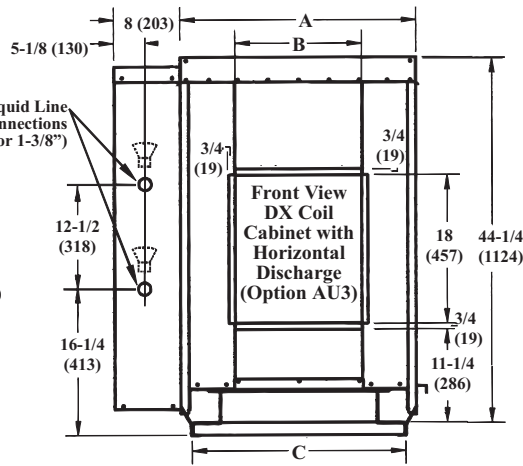
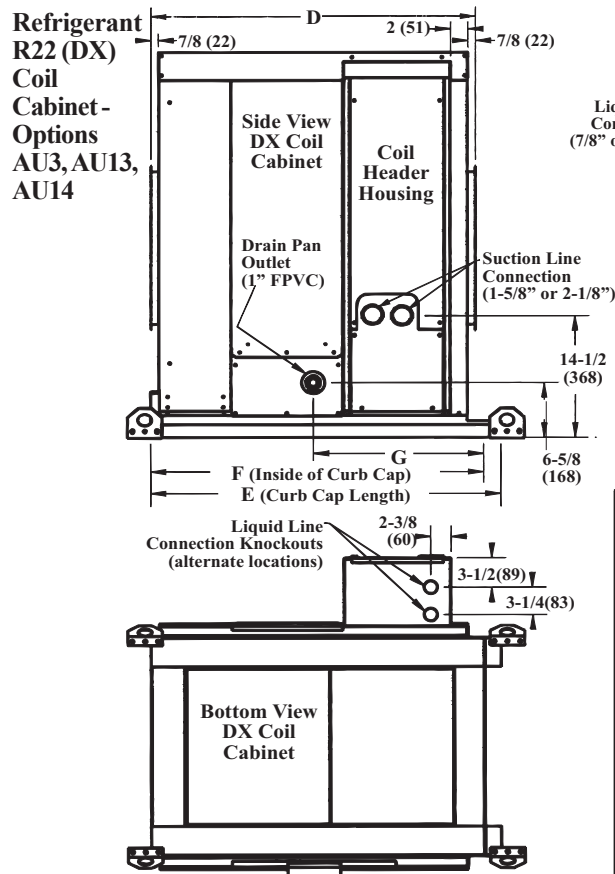

**Figure 1D -
Optional Cooling
Coil Cabinets with
DX or Chilled
Water Coil, with
and without
Downturn Plenum
Cabinet**

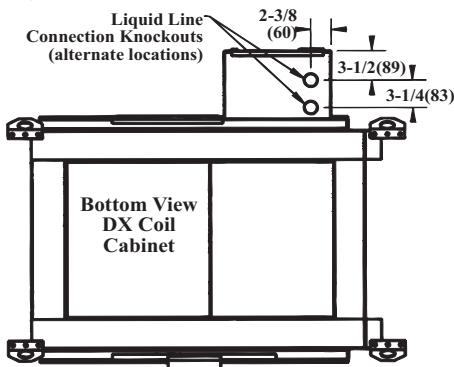

Chilled Water Cooling Coil Cabinet in Options AU2, AU11, AU12

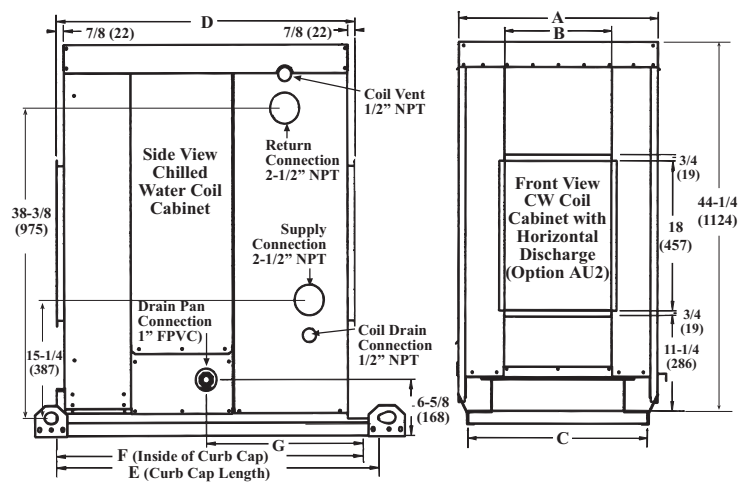

**Downturn Plenum Cabinet (factory attached to
either type of Cooling Coil Cabinet)**

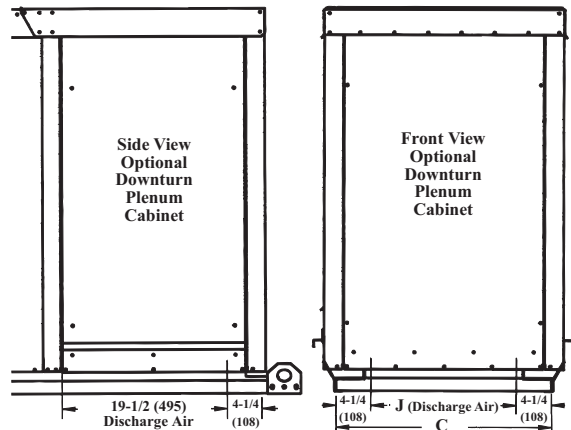

Discharge Damper Note: Optional two-position discharge dampers in Option AU12 or AU14 fit in the discharge air opening. The damper motor fits inside the downturn cabinet. See field wiring instructions in Paragraph 31.

Dimensions (inches \pm 1/8; mm \pm 3)

Furnace Size		75, 100, 125	150, 175	200, 225	250, 300	350	400	
A	inches	28-1/2	34	39-1/2	47-3/4	53-1/4	58-3/4	
	mm	724	864	1003	1213	1353	1492	
B	inches	15-1/4	20-3/4	26-1/4	34-1/2	40	45-1/2	
	mm	387	52	667	876	1016	1156	
C	inches	25-7/8	31-3/8	36-7/8	45-1/8	50-5/8	56-1/8	
	mm	657	797	937	1146	1286	1426	
D	inches	37-1/8	42-5/8	48-1/8	56-3/8	62	67-3/8	
	mm	943	1083	1222	1432	1575	1711	
E	Without Downturn	inches	40	45-5/8	51	59-3/8	64-7/8	70-3/8
		mm	1016	1159	1295	1508	1648	1788
	With Downturn	inches	64	69-5/8	75	83-3/8	88-7/8	94-3/8
		mm	1626	1768	1905	2118	2257	2397
F	Without Downturn	inches	38-1/8	43-5/8	49-1/8	57-3/8	63	68-3/8
		mm	968	1108	1248	1457	1600	1737
	With Downturn	inches	62-1/8	67-5/8	73-1/8	81-3/8	87	92-3/8
		mm	1578	1718	1857	2067	2210	2346
G	inches	19-1/2	22-1/4	25	29-1/8	31-7/8	34-5/8	
	mm	495	565	635	740	810	879	
J	inches	17-3/8	22-7/8	28-3/8	45-1/8	50-5/8	56-1/8	
	mm	441	581	721	1146	1286	1426	

NOTE: For the length of a system with a cooling coil cabinet, see the table on the left. Cooling coil cabinet is shipped separately and attached in the field. See page 10 for roof curb dimensions.

(H)RGB, CRGB, RPB	Width of Cabinets (<i>not curb</i>)				Length of All System Cabinets (<i>not curb</i>)			
	w/Chilled Water Coil Cabinet		w/DX Coil Cabinet		w/Cooling Coil Cabinet only		w/Cooling Coil Cabinet w/Downturn	
	inches	mm	inches	mm	inches	mm	inches	mm
75, 100, 125	29-1/8	740	37-1/8	943	98-1/2	2502	121-5/8	3069
150, 175	34-5/8	879	42-5/8	1083	104	2642	127-1/2	3229
200, 225	40-1/8	1019	48-1/8	1222	109-1/2	2781	132-5/8	3369
250, 300	47-1/8	1197	55-1/8	1400	117-3/4	2991	140-7/8	3578
350	53-3/8	1356	61-3/8	1559	123-3/8	3134	146-1/2	3721
400	58-7/8	1495	66-7/8	1698	128-3/4	3270	151-7/8	3858

5. Clearances

Provide clearance to combustibles as shown in the table. Clearance to combustibles is defined as the minimum distance from the heater to a surface or object that is necessary to ensure that a surface temperature of 90°F above the surrounding ambient temperature is not exceeded. Clearance is also required to sides of furnace for combustion air space and for convenient installation and burner control system service.

REQUIRED CLEARANCES					
Model	Top	Sides		Bottom	
		Control	Opposite	To Combustibles	To Non-Combustibles
XE	6" (152mm)	Width of furnace plus 6"	6" (152mm)	3" (76mm)	0
RPB, (C)RGB	36" (915mm)		6" (152mm)	0 *	0
(C)RGB	30' (9M) radius from center of vent cap to obstructions such as walls, parapets or cupolas				
* When installed on a roof curb on a combustible roof, the roof area enclosed within the curb must be either ventilated, left open, or covered with non-combustible material which has an "R" value at least 5.0. See Figure 8, page 10.					

6. Combustion Air Requirements

6A. Indoor, Gravity-Vented Models

These duct furnaces are designed to take combustion air from the space in which the furnace is installed. The air that enters into the combustion process is vented to the outdoors. Sufficient air must enter the equipment location to replace the air exhausted through the vent system. Modern construction methods involve the greater use of insulation, improved vapor barriers and weather-stripping, with the result that buildings generally are much tighter structurally than they have been in the past. The combustion air supply for gas-fired equipment can be affected by these construction conditions because infiltration that would have existed in the past may not be adequate. Extensive use of exhaust fans aggravates the situation. In the past the filtration of outside air assumed in heat loss calculations (one air change per hour) was assumed to be sufficient. However, current construction methods may now require the introduction of outside air through wall openings or ducts.

Requirements for combustion air and ventilation air depend upon whether the unit is located in a confined or unconfined space. An "unconfined space" is defined as a space whose volume is not less than 50 cubic feet per 1000 BTUH of the installed appliance. Under all conditions, enough air must be provided to ensure there will not be a negative pressure condition within the equipment room or space. A positive seal must be made in all return-air connections and ducts. Even a slight leak can create a negative pressure condition in a confined space and affect combustion.

WARNING: These gravity-vented, indoor furnaces are designed to take combustion air from the space in which the furnace is installed and are not designed for connection to outside combustion air intake ducts. Use of outside air ducts voids the warranty and could cause hazardous operation. See Hazard Levels, page 2.

Indoor, Gravity-Vented Furnace Located in a Confined Space

Do not install a unit in a confined space without providing wall openings leading to and from the space. Provide openings near the floor and

Figure 2 - Confined Space: A space whose volume is less than 50 cubic feet per 1000 BTUH of the installed appliance input rating

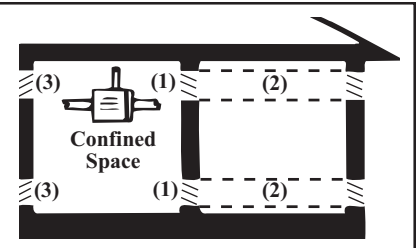

ceiling for ventilation and air for combustion as shown in Figure 2, depending on the combustion air source as noted in Items 1, 2 and 3.

Add total BTUH of all appliances in the confined space and divide by figures below for square inch free area size of each (top and bottom) opening.

1. Air from inside the building -- openings 1 square inch free area per 1000 BTUH. Never less than 100 square inches free area for each opening. See (1) in Figure 2.

2. Air from outside through duct -- openings 1 square inch free area per 2000 BTUH. See (2) in Figure 2.

3. Air direct from outside -- openings 1 square inch free area per 4000 BTUH. See (3) in Figure 2.

NOTE: For further details on supplying combustion air to confined space, see National Fuel Gas Code ANSI Z223.1a (latest edition) 5.3.3.

6B. Combustion Air for Gravity-Vented, Outdoor Models

Combustion air enters through the screened air intakes located in the furnace section access doors.

6C. Combustion Air for Power-Vented, Outdoor Models

The combustion air and flue gas openings are carefully designed screened openings located on the side of the unit just above the control access panel. Location of the flue opening directly above the air intake is designed to discourage recirculation of combustion products. See Figure 3.

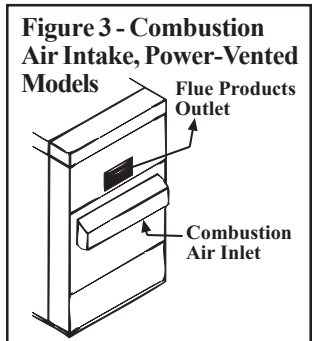

6D. Chlorine -- All Models

The presence of chlorine vapors in the combustion air of gas-fired heating equipment presents a potential corrosion hazard. Chlorine will, when exposed to flame, precipitate from the compound, usually freon or degreaser vapors, and go into solution with any condensation that is present in the heat exchanger or associated parts. The result is hydrochloric acid which readily attacks all metals including 300 grade stainless steel.

Care should be taken to separate these vapors from the combustion process. This may be done by wise location of the furnace with regard to exhausters or prevailing wind direction. Remember, chlorine is heavier than air. This fact should be kept in mind when determining installation locations of heating equipment and building exhaust systems.

7. Suspending/Mounting

7A. Suspending/Mounting Indoor, Gravity-Vented Model

Location - Before suspending the furnace, check the supporting structure to verify that it has sufficient load-carrying capacity to support the weight of the unit.

Approximate Net Weight - Indoor Furnaces							
Size	75-100	125	150-175	200-225	250-300	350	400
lbs	233	295	332	386	494	515	576
kg	106	134	151	175	224	234	261

7A. Suspending/Mounting Indoor, Gravity-Vented Model (cont'd)

WARNING: Avoid installing a unit in an extremely drafty area. Extreme drafts can shorten the life of the heat exchanger and/or cause safety problems.

Suspending Furnaces

These indoor, packaged furnace/blower systems have four-point suspension. See hanger dimensions in Paragraph 4, Figure 1A. At each suspension point, the unit is factory-equipped with a free-turning, female, 1" (NPT) pipe hanger. Suspend by connecting the pipe hanger to a 1" threaded pipe. See the suspension method on the left in Figure 4. As an alternative method, the factory-installed pipe hanger may be removed and the heater suspended as illustrated on the right in Figure 4.

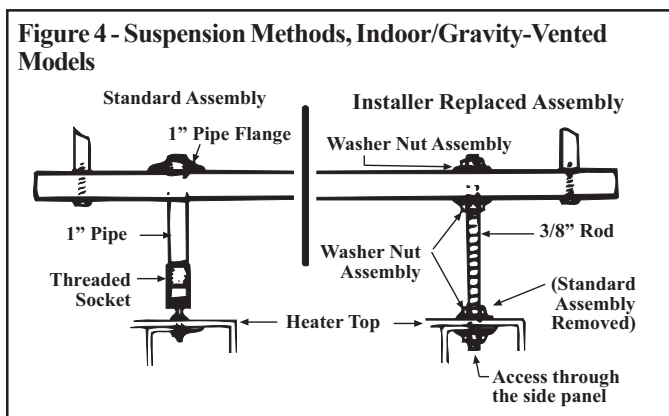

WARNING: Unit must be level for proper operation. Do not place or add additional weight to the suspended unit. See Hazard Levels, page 2.

Mounting Furnaces

Indoor packaged systems require six support locations. See Figure 5. All supports must be non-combustible.

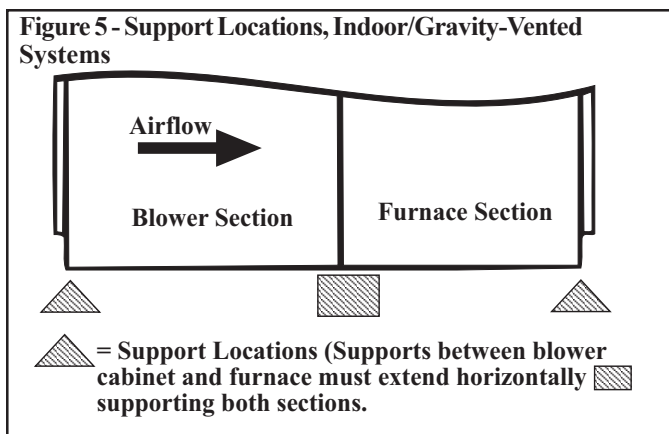

WARNING: Do not support an indoor/gravity-vented system with four corner support legs. The system requires additional support as illustrated in Figure 5. Bottom clearance to combustibles must be observed.

7B. Mounting Outdoor Models

Rigging - Lifting holes are provided for rigging. Use spreader bars when lifting to prevent chains or cables from damaging the unit. If the unit is being mounted on a roof curb, apply caulking to the roof curb

prior to lifting the unit to the roof and setting it on the curb. See Figure 8, page 10. If the system includes an outside air hood or a shipped-separate cooling coil cabinet, attach them after the unit is in place.

Approximate Net Weight (lbs/kg) - Outdoor Systems (blower and furnace sections only)								
Size		75-100	125	150-175	200-225	250-300	350	400
(C)RGB	lbs	439	472	510	529	573	624	655
	kg	199	214	231	240	260	283	297
RPB	lbs	--	482	520	534	588	630	662
	kg	--	219	236	242	267	286	300

If the system includes a cooling coil cabinet, the cooling coil cabinet must be lifted to the roof separately, set on the roof curb or supports, and attached to the furnace.

Approximate Net Weight (lbs/kg) - Optional Cooling Coil Cabinet (includes approximate weight of a coil with 12ft)							
Size		75-100-125	150-175	200-225	250-300	350	400
DX	lbs	377	464	551	661	753	848
	kg	171	269	250	300	342	385
DX w/ Downturn	lbs	497	593	689	813	914	1018
	kg	225	269	313	369	415	462
Chilled Water	lbs	369	457	544	654	746	841
	kg	167	207	247	297	338	381
Chilled Wtr w/Dwntrn	lbs	490	586	682	806	907	1011
	kg	222	266	309	366	411	459

Location - When selecting a location for an outdoor installation, position the unit so that the air inlet will not be facing into the prevailing wind.

When the unit is mounted on a roof over 20' high, has parapet walls or obstructions within 30', or is subject to winds over 25 mph, installation of a power-vented unit (Model RPB) is recommended.

Curb Cap Base

Outdoor systems are equipped with a load bearing curb cap which forms an integral part of the unit. This curb cap has welded joints and has a "skirt" which fits over a roof curb to provide a weatherproof installation. Four holes are provided at the curb cap corners for lifting the unit. These holes do not interfere with unit weatherproofing. The **curb cap is not designed to be placed directly on the roof surface.** The system may be mounted on an optional roof curb purchased with the unit, a field-supplied roof curb, or field-supplied supports. If the system has a downturn plenum and/or a bottom return air opening, a roof curb is recommended to provide a weatherproof installation as well as more workable clearances for ductwork. If the unit has an optional cooling coil cabinet, the cabinet is shipped separately and attached in the field. The cooling coil cabinet has a curb cap base that "matches and extends" the length of the system base.

Mounting on Field-Supplied Supports (without a roof curb) - Prior to installation, be sure that the method of support is in agreement with all local building codes and is suited to the climate. If considering this type of installation in snow areas, it is recommended that the 4x4 wooden rails underneath the system be on cross-support structure at least 12" higher than the roof surface (see cross support locations in Figure 6B).

Whether the supports are being mounted directly on the roof or being placed "up" on additional structure, the horizontal length of the system should be supported by two 4x4 treated wooden rails. Cut the rails to the appropriate length (Dimension "A") in Figure 6A. (NOTE: Although dimensions are included for units with a downturn plenum cabinet, it is strongly recommended that a full roof curb be used on an installation with a downturn plenum cabinet and/or a bottom return air duct.)

Space the 4x4 wooden rails (See "B" Dimension, Figure 6A) so that the curb cap "skirt" will fit over the edge of the boards with the rails setting inside the horizontal length of the curb cap.

If the rails are being laid directly on the roof, position them as shown in Figure 6A. Set the system on the rails, leaving the "ends" underneath open for ventilation.

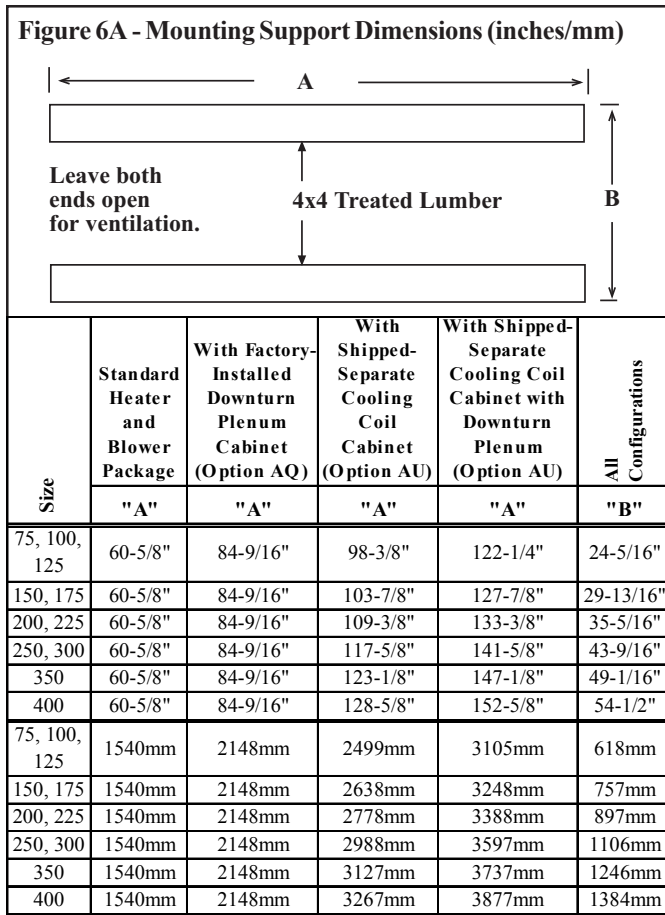

If the treated wooden rails are not being placed directly on the roof surface, cross-supports should be placed underneath the rails at the ends of the unit and at all cabinet "joints" (between the blower cabinet and the furnace section; between the furnace and the optional downturn plenum or coil cabinet; and between a coil cabinet and a downturn plenum). See Figure 6B.

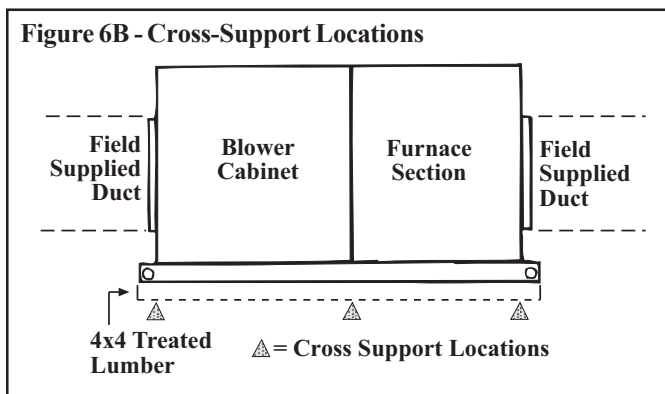

The field-supplied, weather-resistant cross-support structure must be adequate for the weight of the system (including air conditioning coil if applicable), and all cross-supports should run the entire width of the system supporting the 4x4 wooden rails at the recommended locations.

Mounting on a Roof Curb - Whether using an optional roof curb available with the system or a field-supplied curb, the curb must be secure, square and level. The top surface of the roof curb must be caulked with 1/4" x 1-1/4" sealant tape or two 1/4" beads of suitable sealant. The unit must be sealed to the curb to prevent water leakage into the curb area due to wind blown rain and capillary action. Except for the curb assembly details which are specific to the optional roof

curb available with the system, the information and requirements in this section apply to all curbs. See Figure 8, page 10, and the curb installation instructions below.

Bottom Duct Connections - The blower section and optional downturn plenum have duct flanges for connection to return air and supply air ducts. Duct opening sizes and curb spacing shown in Figure 7 is for currently manufactured curbs that are available from the system manufacturer.

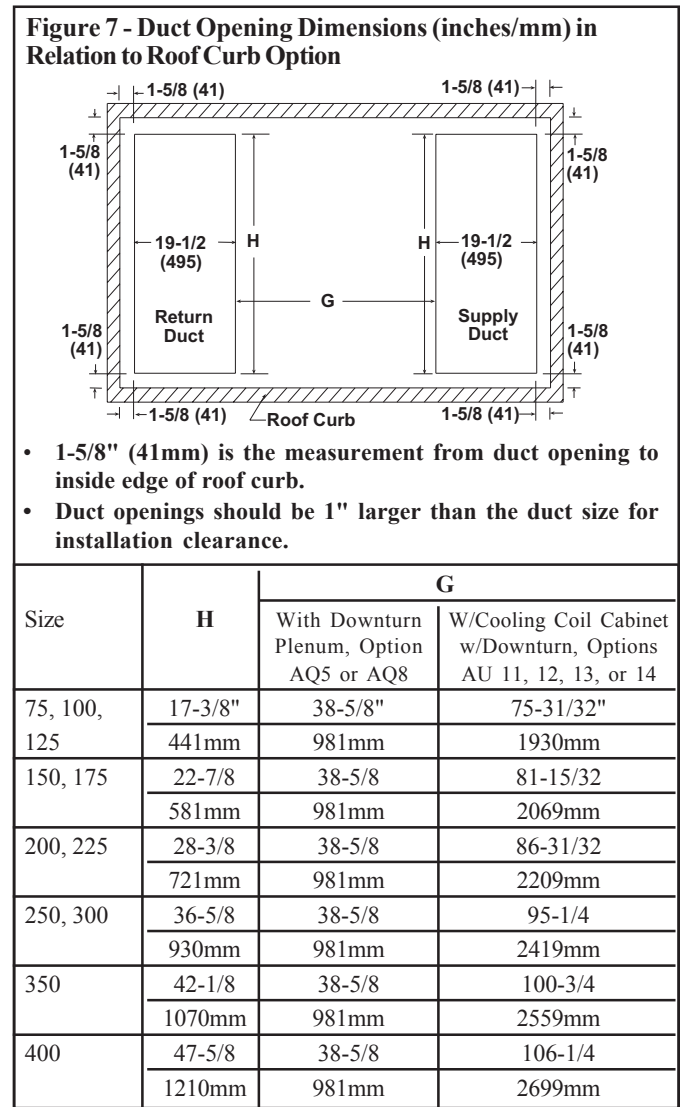

- 1-5/8" (41mm) is the measurement from duct opening to inside edge of roof curb.
- Duct openings should be 1" larger than the duct size for installation clearance.

Roof Curb Assembly and Installation Instructions (Refer to Figure 8, page 10)

Curbs are shipped unassembled. Field assembly and mounting on the roof are the responsibility of the installer. All required hardware necessary to complete the assembly is supplied.

Before installing roof curb, verify that the size is correct for the system being installed.

1. Position curb cross rails and curb side rails as illustrated in Figure 8, page 10. If there are two side pieces to a side, fasten them with splice plates and hardware as illustrated in the splicing detail drawing. Join the corners as illustrated in the corner detail.
2. Check the assembly for squareness. Adjust the roof curb so that the diagonal measurements are equal within a tolerance of + or - 1/8".
3. Level the roof curb. To ensure a good weather tight seal between the curb cap and the roof curb, the roof curb must be leveled in both directions with no twist end to end. Shim level as required and secure curb to roof deck before proceeding with flashing.

7B. Mounting Outdoor Models on a Roof Curb (cont'd)

Roof Curb Assembly and Installation Instructions (Refer to Figure 8) (cont'd)

- Install field-supplied flashing.
- Before placing the unit into position, apply furnished 1/4" x 1-1/4" foam sealant tape to top surface of curb, making good butt joint at corners. The unit must be sealed to the curb to prevent water leakage into the curb area due to blown rain and capillary action.

Figure 8 - Optional Roof Curb

***Optional Downturn Plenum**

Lift Holes (4 corners)

1-1/2\" (38mm)

1-7/8\" (48mm)

1-7/8\" (48mm)

16\" (406mm)

IMPORTANT: Area enclosed by the roof curb must comply with clearance to combustible materials. If roof is constructed of combustible materials, area within curb must be either ventilated, left open, or covered with non-combustible material which has an "R" value of at least 5.0. If area within curb is left open, higher radiated sound levels may result.

IMPORTANT: Top surface of curb **MUST** be sealed. See instructions above.

* Illustration is shown with an Option AQ5 or AQ8 downturn plenum. The system can have a variety of configurations which affect installation.

- If the system does not have a downturn plenum, the discharge is horizontal.
- Downturn plenum **Options AQ5 and AQ8** are factory installed to be **lifted to the roof** and set on the roof curb as part of the packaged system.
- If the system has an Option AU2 or AU3 cooling coil cabinet, the discharge is horizontal. If the system has an AU11, AU12, AU13, AU14 cooling coil cabinet, there is a downturn plenum with vertical discharge. **Options AU2, AU3, AU11, AU12, AU13, and AU14 are not factory installed. Options AU2, AU3, AU11, AU12, AU13, and AU14 must be lifted to the roof separately from the packaged system, set on the roof curb, and attached to the furnace.**

Splicing Detail

For top two holes at both joints, from *inside* the curb insert (4) 5/16" x 1" lag screws and (4) 5/16" lockwashers.

For bottom six holes at both joints, from *outside* of the curb insert (12) 5/16-18 x 3/4" long cap screws. Attach with (12) 5/16" lockwashers and (12) 5/16-18 hex nuts.

Curb Section

1-7/8" (48mm)

16" (406mm)

4" (102mm)

2 x 6 Wood Nailer

1-1/2 x 3 lb Fiberglass

Flashed by the installer (flashing must be under lip of curb)

Lag Screw

Cap Screws

Corner Detail

Typical Curb Detail

Cabinet

MUST be sealed between curb cap and roof curb

Curb Side

2 x 6 Wood Nailer

16" (406mm) Curb Height

Insulation

Counter Flashing (by installer)

Cant Strip (by installer)

Roofing Felts (by others)

Weld, bolt, or lag screw curb to deck structure.

Roof Curb Dimensions (inches)

Size	75, 100, 125	150, 175	200, 225	250, 300	350	400
Option CJ1 - Roof Curb for RGB/RPB**						
A	60-5/8	60-5/8	60-5/8	60-5/8	60-5/8	60-5/8
B	24-5/16	29-13/16	35-5/16	43-9/16	49-1/16	54-1/2
C***	56-15/16	56-15/16	56-15/16	56-15/16	56-15/16	56-15/16
D***	20-9/16	26-1/16	31-9/16	39-13/16	45-5/16	50-13/16
Option CJ2 - Roof Curb for RGB/RPB** with Factory-Installed Downturn Plenum Option AQ5 or AQ8						
A	84-9/16	84-9/16	84-9/16	84-9/16	84-9/16	84-9/16
B	24-5/16	29-13/16	35-5/16	43-9/16	49-1/16	54-1/2
C***	80-13/16	80-13/16	80-13/16	80-13/16	80-13/16	80-13/16
D***	20-9/16	26-1/16	31-9/16	39-13/16	45-5/16	50-13/16
Option CJ4 - Roof Curb for RGB/RPB** with Field-Installed*** Cooling Coil Cabinet Option AU2 or AU3						
A	98-3/8	103-7/8	109-3/8	117-21/32	123-5/32	128-21/32
B	24-5/16	29-13/16	35-5/16	43-9/16	49-1/16	54-1/2
C***	94-5/8	100-1/8	105-5/8	113-29/32	119-13/32	124-29/32
D***	20-9/16	26-1/16	31-9/16	39-13/16	45-5/16	50-13/16
Option CJ5 - Roof Curb for RGB/RPB** with Field-Installed*** Cooling Cabinet and Downturn Plenum Option AU11, AU12, AU13, or AU14						
A	122-3/8	127-7/8	133-3/8	141-21/32	147-5/32	152-21/32
B	24-5/16	29-13/16	35-5/16	43-9/16	49-1/16	54-1/2
C***	118-5/8	124-1/8	129-5/8	137-29/32	143-13/32	148-29/32
D***	20-9/16	26-1/16	31-9/16	39-13/16	45-5/16	50-13/16

**Applies to Models with prefix "C", "H", and "HC"

***C and D are roof opening dimensions.

**** Field installed means that the cooling coil cabinet with or without the downturn is factory assembled and shipped separately. The roof curb is sized to accommodate the complete length of the system. The shipped-separate cooling coil cabinet with or without a downturn must be lifted to the roof separately from the packaged system, set on the roof curb, and attached to the furnace section (see instructions on page 38).

Roof Curb Dimensions (mm)

Size	75, 100, 125	150, 175	200, 225	250, 300	350	400	Size	75, 100, 125	150, 175	200, 225	250, 300	350	400
Option CJ1 - Roof Curb for RGB/RPB**							Option CJ4 - Roof Curb for RGB/RPB** with <i>Field-Installed****</i> Cooling Coil Cabinet Option AU2 or AU3						
A	1540	1540	1540	1540	1540	1540	A	2499	2638	2778	2988	3128	3267
B	618	757	897	1106	1246	1384	B	618	757	897	1106	1246	1384
C***	1446	1446	1446	1446	1446	1446	C***	2403	2543	2683	2893	3033	3173
D***	522	662	802	1011	1151	1291	D***	522	662	802	1011	1151	1291
Option CJ2 - Roof Curb for RGB/RPB** with <i>Factory-Installed</i> Downturn Plenum Option AQ5 or AQ8							Option CJ5 - Roof Curb for RGB/RPB** with <i>Field-Installed****</i> Cooling Cabinet and Downturn Plenum Option AU11, AU12, AU13, or AU14						
A	2148	2148	2148	2148	2148	2148	A	3108	3248	3388	3598	3738	3877
B	618	757	897	1106	1246	1384	B	618	757	897	1106	1246	1384
C***	2053	2053	2053	2053	2053	2053	C***	3013	3153	3292	3503	3643	3759
D***	522	662	802	1011	1151	1291	D***	522	662	802	1011	1151	1291

**Applies to Models with prefix "C", "H", and "HC"

***C and D are roof opening dimensions.

**** Field installed means that the cooling coil cabinet with or without the downturn is factory assembled and shipped separately. The roof curb is sized to accommodate the complete length of the system. The shipped-separate cooling coil cabinet with or without a downturn must be lifted to the roof separately from the packaged system, set on the roof curb, and attached to the furnace section (see instructions on page 38).

8. Venting

8A. Gravity-Vented Indoor Models

Furnaces have the following vent outlet sizes:

Model Size	75	100	125	150, 175	200, 225	250, 300	350, 400
Flue Collar Diameter/Configuration	5" Round	6" Round	7" Oval	8" Oval	8" Round	10" Oval	12" Oval

DANGER: Failure to provide proper venting could result in death, serious injury, and/or property damage. This furnace must be installed with a vent connection and proper vent to the outside of the building. Install vent in accordance with Part 7, Venting of Equipment, of the National Fuel Gas Code, ANSI Z223.1 (latest edition) or applicable provision of national, state or local codes. A Canadian installation must be in accordance with the CAN/CGA B149.1 and B149.2, Installation Code for Gas Burning Appliances and Equipment, and applicable local codes. Also, follow venting recommendations listed below.

Safe operation of any gravity-vented gas-fired equipment requires a properly operating vent system, correct provision for the combustion air (See Paragraph 6) and regular maintenance and inspection. See Hazard Levels, page 2.

Venting Requirements - All Models

1. Provide a minimum clearance of 18" between the drafthood relief opening and any obstruction. Do not expose the relief opening to wind drafts from any source such as from an overhead door or adjacent air handling equipment.
2. The unit is equipped with a built-in draft diverter, consequently an external draft diverter **MUST NOT** be installed in the vent connector or any internal alterations made. Do not install a manual damper or other fixed restriction in the vent connector.
3. Vent pipe should be a minimum of 24 gauge galvanized steel or other noncorrosive material. Double wall, Type B vent is recommended. Where it is necessary to run the vent pipe through an exterior wall of combustible materials, a suitable thimble must be used. The vent pipe shall have a clearance of at least six inches from combustible materials, or as is specified by the double-wall vent pipe manufacturer.
4. The horizontal vent pipe run should have a uniform rise of at least 1/4" per foot of horizontal run in the direction of discharge. The length of the lateral run must not exceed lengths showing in the vent tables of the National Fuel Gas Code or the Canadian Installation Code for Gas Burning Appliances. See Tables 1 and 2 on the right.

Vertical Height of Vent	Vent Diameter											
	5"		6"		7"		8"		10"		12"	
	ft	M	ft	M	ft	M	ft	M	ft	M	ft	M
6' (1.8M)	6	1.8	6	1.8	6	1.8	6	1.8	6	1.8	6	1.8
8' (2.4M)	8	2.4	8	2.4	16	4.9	16	4.9	16	4.9	16	4.9
10' (3.0M)	10	3.0	16	4.9	20	6.1	20	6.1	20	6.1	20	6.1
15' (4.6M)	16	4.9	16	4.9	30	9.1	30	9.1	30	9.1	30	9.1
20' (6.1M)	20	6.1	30	9.1	30	9.1	30	9.1	30	9.1	30	9.1
30' (9.1M)	20	6.1	40	12.2	40	12.2	40	12.2	40	12.2	40	12.2

Vertical Height of Vent	Vent Diameter											
	5"		6"		7"		8"		10"		12"	
	ft	M	ft	M	ft	M	ft	M	ft	M	ft	M
6' (1.8M)	2	0.6	2	0.6	2	0.6	2	0.6	2	0.6	2	0.6
8' (2.4M)	5	1.5	5	1.5	10	3.0	10	3.0	10	3.0	10	3.0
10' (3.0M)	5	1.5	10	3.0	15	4.6	15	4.6	15	4.6	15	4.6
15' (4.6M)	5	1.5	10	3.0	15	4.6	20	6.1	20	6.1	20	6.1
20' (6.1M)	N.R.		10	3.0	15	4.6	20	6.1	20	6.1	20	6.1

8. Venting (cont'd)

Venting Requirements - All Model (cont'd)

- Lateral runs should be supported every six feet using a non-combustible material, such as strap steel or chain. Do not rely on the drafthood or heater for support of either horizontal or vertical vent pipe.
- Vent connectors serving Category I heaters (heater with non-positive vent pressure and with a vent gas temperature at least 140°F above its dew point) shall not be connected into any portion of a mechanical draft system operating under positive pressure.
- Where it is necessary to use a long run of vent pipe, or where the vent pipe is exposed to cold air, condensation within the pipe may occur. There are two ways to overcome or eliminate this problem.
 - Prevent condensation by insulating the pipe so that the temperature of the flue products never drops below 250°F.
 - Use double-wall, Type B vent pipe which is recommended for the reduction or elimination of condensate problems. Where extreme conditions are present and condensate is anticipated, install a trap for collecting condensate.
- The vent connection may be made into a suitable permanent chimney or into a gas vent. The effective area of the vent connector, gas vent or chimney when connected to a single appliance shall not be less than the area of the appliance drafthood outlet or in accordance with approved venting methods. The effective area of the gas vent or chimney when connected to more than one appliance shall not be less than the area of the largest vent connector plus 50% of the areas of additional vent connectors or in accordance with approved venting methods.
Minimum permissible height of the vertical vent is five feet providing no horizontal vent pipe connector is used. If a horizontal vent connector is necessary, consult Tables 1 and 2 or the National Fuel Gas Code or the Canadian Installation Code for Gas Burning Appliances, for the maximum permissible length of a horizontal pipe run (vent connector) for a given vertical height of gas vent.
The gas vent or chimney should extend at least three feet above the highest point where it passes through a roof of a building and at least two feet higher than any portion of a building or obstruction within a horizontal distance of ten feet. A suitable weather cap should be installed on the end of the vent pipe to prevent rain or snow from entering the open end.
- If the unit heater is installed in a space served by a large exhaust fan, be sure that the exhaust fan does not affect the operation of the heater or the satisfactory venting of its products of combustion.
If a negative pressure exists, as evidenced by a downdraft, a factory-designed mechanical motor drive venter (Option CA) should be installed. In severe negative pressure conditions, makeup air equipment may be necessary.

Optional Power Venting (Option CA)

To install a gravity-vented furnace in an area where horizontal venting is required or where negative building pressure inhibits gravity venting, include an optional power venter in the application. Use only a power venter provided by the furnace manufacturer and carefully follow the instructions included in the optional venter package. Use the venter adapter provided to connect the power venter to the heater. **Do not install the power venter without the venter adapter.**

With an Option CA power venter installed, the furnace may be vented either horizontally or vertically. Do not exceed the maximum vent lengths shown in Table 3.

Vent Pipe Diameter	75 - 150		175		200		225		250		300		350		400	
	ft	M	ft	M	ft	M	ft	M	ft	M	ft	M	ft	M	ft	M
4"	100	30	75	23	50	15	35	11	30	9	15	4.6	-	-	-	-
6"	-	-	-	-	-	-	-	-	100	30	100	30	100	30	92	28

8B. Venting - Gravity-Vented, Outdoor Models

The appropriate size of gravity vent cap is supplied with the furnace. **The gravity vent cap requires field installation.**

Model	Size	Vent Cap Size	Extension Required
(H)-RGB/CRGB	75, 100	6"	No
(H)-RGB/CRGB	125, 150, 175	8"	
(H)-RGB/CRGB	200, 225, 250	10"	
(H)-CRGB	300	10"	Yes (packed inside cap)
(H)-RGB	300	12"	
(H)-RGB/CRGB	350, 400	12"	

WARNING: This gravity-vented furnace should be located on a roof or slab with at least 30-foot (9M) radius between the center of the vent cap and obstructions such as walls, parapets or cupolas. See Hazard Levels, page 2.

Vent Cap Installation Instructions:

IMPORTANT REQUIREMENT

For proper operation of the gravity vent cap, position the holes so that the solid side panel of the cap will face the control compartment access panel side of the furnace. See Figure 9B.

1) Furnaces that *do not* require a Vent Cap Extension

All Sizes 75-250 and high efficiency Size 300, align holes and attach the vent cap to the furnace flue collar with sheetmetal screws. (See Important Requirement above.)

2) Furnaces that *require* a Vent Cap Extension (packed inside the vent cap) - See Figures 9A and 9B

Standard (78%) efficiency furnace Size 300 and all Sizes 350 and 400 require a 12" extension to raise the vent cap above the top of the furnace.

a) Remove the extension from the inside of the cap.

b) Attach the extension to the furnace flue collar --

- With 3/8" centerline clearance holes at the bottom, wrap extension around flue collar on the top of the furnace.
- Align holes in the extension with holes in the flue collar.
- Secure with No. 10-1/2" sheetmetal screws.

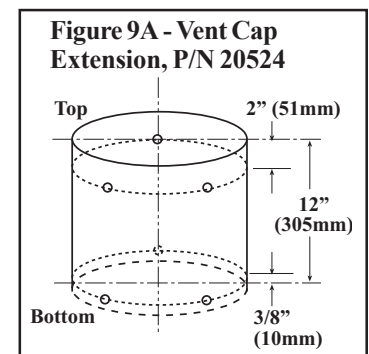
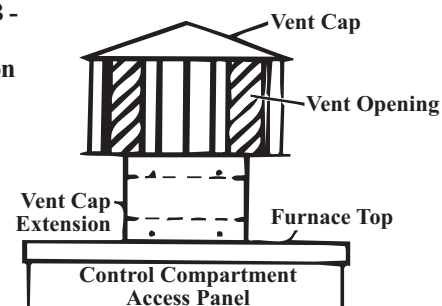

Figure 9B - Vent Cap Installation



c) Attach the vent cap to the extension --

- 1) Position vent cap *into* top of extension. (See **Important Requirement** above)
- 2) Align holes and push cap into extension.
- 3) Secure with No. 10-1/2" sheetmetal screws.

Optional 4-foot (1.2M) Stack Extension for Outdoor, Gravity Vent Models (Option ZZ)

Outdoor, gravity-vented furnaces that are factory-built with Option ZZ are designed to release flue gases four feet above the top of the furnace. A field-provided 4-ft (1.2M) vent extension must be installed between the top of the furnace and the bottom of the vent cap. (See Figure 9C). Furnaces with Option ZZ (factory-installed restrictor plus field-provided 4-ft stack) may be installed adjacent to fresh air inlet(s) when local code requires that release of flue gases be above an adjacent fresh air inlet that is not part of the furnace.

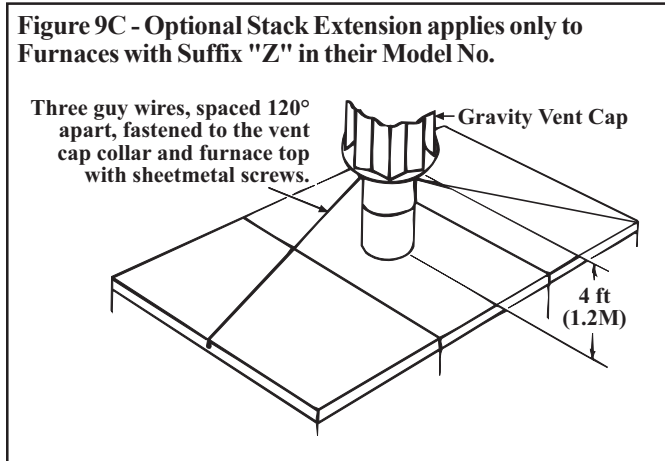

8C. Venting - Power Vented, Outdoor Models

Locate power-vented furnaces so that flue discharge is not directed at fresh air inlets.

Flue Gas and Combustion Air Openings

These screened openings are located on the side of the furnace just above the control access panel. See Figure 10. The position of these openings discourages recirculation of combustion products and provides for furnace operation in all normal weather conditions.

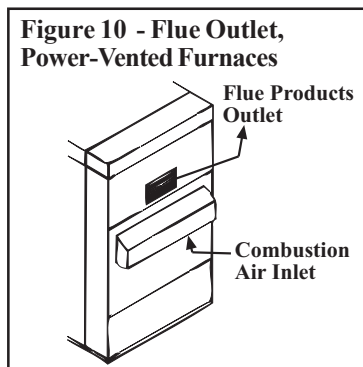

Optional Vertical Flue Discharge (Option CC3)

These power vented furnaces are certified with four feet of vertical pipe attached as shown in Figures 11A and 11B. The distance is measured from the top of the unit to the bottom of the vent cap. The option package includes the 5" vent cap, the adapter assembly and the seal plate. The vent pipe and supports are field supplied. **The straight pipe connecting the furnace to the 90° elbow must be at least 18" in length.**

Optional vertical vent piping provides compliance with local codes that require either 10-ft horizontal or 4-ft vertical clearance between the flue outlet and fresh air intake of the heating system and/or the building.

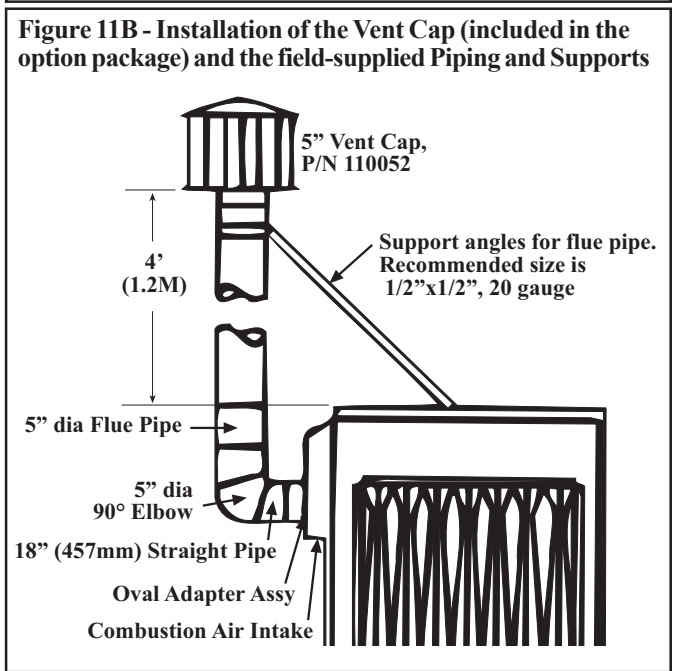
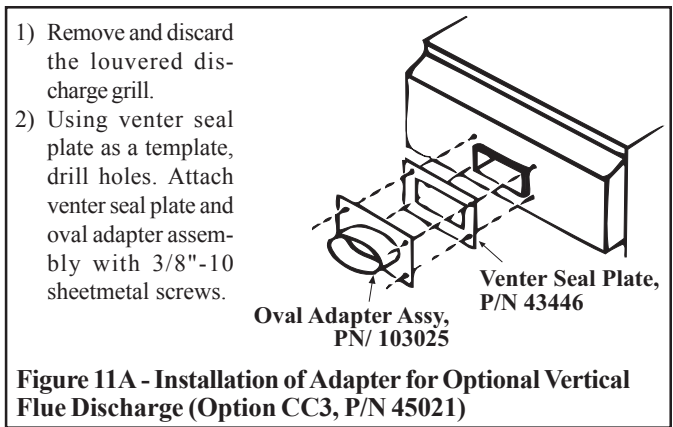

9. Condensate Drain

9A. Indoor Models

Condensate can form in the heat exchanger of furnaces installed as makeup air units or when installed downstream from a cooling coil. Under these conditions, a drain flange, Option CS1, may be installed on the furnace bottom as shown in Figure 12. When using Option CS1, seal all corners and the four square holes in the bottom pan edge.

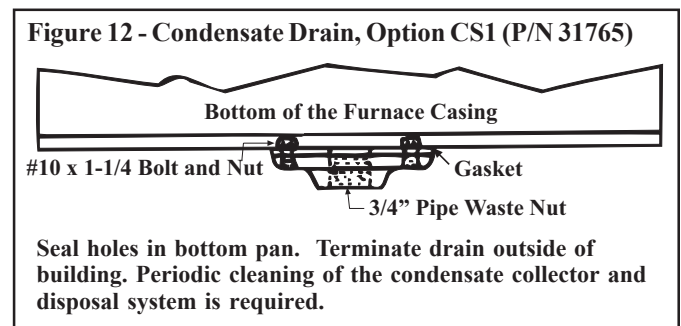

9B. Outdoor Models

A hole is provided in all four corners of the furnace bottom to drain off condensation to the outside of the curb cap to the roof.

10. Duct Connections

Requirements and Suggestions for Connecting and Installing Ducts

- **Type of Ductwork** - The type of duct installation to be used depends in part on the type of construction of the roof (whether wood joist, steelbar joist, steel truss, pre-cast concrete) and the ceiling (whether hung, flush, etc.).
- **Ductwork Material** - Rectangular duct should be constructed of not lighter than No. 26 U.S. gauge galvanized iron or No. 24 B & S gauge aluminum.
- **Ductwork Structure** - All duct sections 24 inches or wider, and over 48 inches in length, should be cross broken on top and bottom and should have standing seams or angle-iron braces. Joints should be S and drive strip, or locked.
- **Through Masonry Walls** - No warm air duct should come in contact with masonry walls. Insulate around all air duct through masonry walls with not less than 1/2" (1" is recommended) of insulation.
- **Through Unheated Space** - Insulate all exposed warm air ducts passing through an unheated space with at least 1/2" (1" is recommended) of insulation.
- **Duct Supports** - Suspend all ducts securely from adjacent buildings members. Do not support ducts from unit duct connections.
- **Duct Sizing** - Proper sizing of the supply air ductwork is necessary to ensure a satisfactory heating installation. The recognized authority for such information is the Air Conditioning Contractors Association, 1228 17th Street N.W., Washington, D.C. 20036. A manual covering duct sizing in detail may be purchased directly from them.

CAUTION: An external duct system static pressure not within the limits shown on the rating plate, or improper motor pulley or belt adjustment, may overload the motor. See Hazard Levels, page 2.

- **Removable Panels** - The ducts should have removable access panels on both upstream and downstream sides of the furnace. These openings must be accessible when the furnace is in service and should be a minimum of 6" x 10" in size so smoke or reflected light may be observed inside the casing to indicate the presence of leaks in the heat exchanger. The covers for the openings must be attached in such a manner as to prevent leakage. See Figure 14, page 14.
- **Horizontal Discharge Duct Length** - On indoor, gravity-vented Model XE, a **minimum** horizontal duct length of 18" is required at the furnace discharge before any vertical rise is made in front of the draffhood relief opening. This is required to prevent interference with the built-in draffhood. For all installations with a horizontal discharge, a minimum horizontal duct run of 24" is recommended before turns or branches are made in the duct system to reduce losses at the furnace outlet.

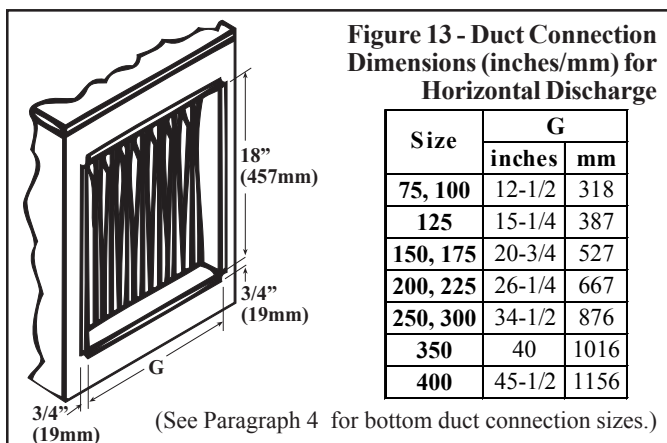

- **Supply Air Duct/Furnace Horizontal Connection** - The seal between the furnace and the duct must be mechanical. Duct connection should be made with "U" type flanges on the top and bottom of the connecting duct. Slide the duct over the flanges of the heater giving an airtight fit. Provide "U" type channels for the other side flanges to ensure tight joints. Use sheetmetal screws to fasten ducts and "U" channels to the furnace flange. See Figures 14 and 15.

CAUTION: Joints where supply air ducts attach to the furnace must be sealed securely to prevent air leakage into draffhood or burner rack area. Leakage can cause poor combustion, pilot problems, shorten heat exchanger life and cause poor performance. See Hazard levels, page 2.

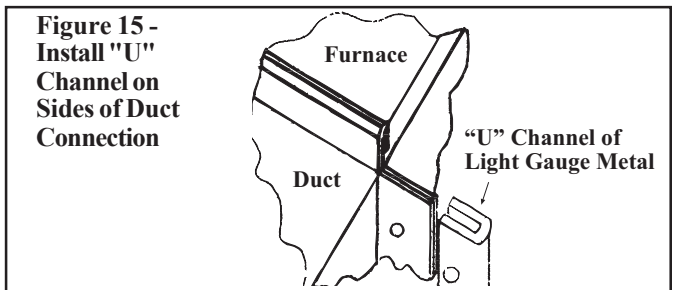
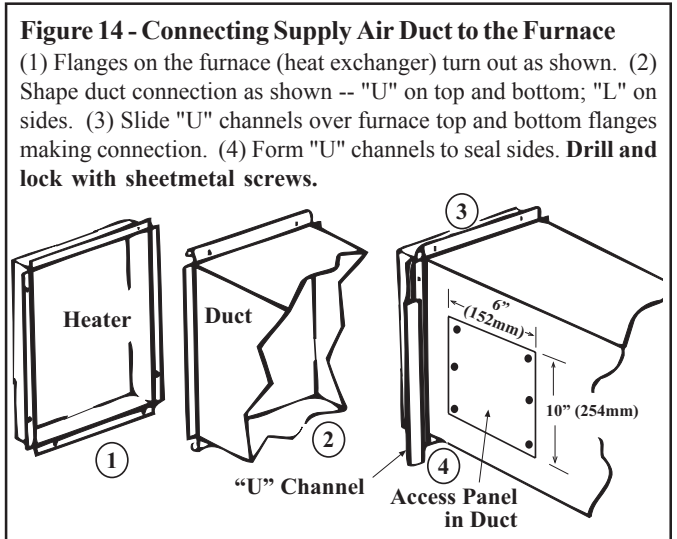

- **Bottom Duct/Furnace Connections** - On outdoor models, insert ducts from below roof deck through roof opening into the heater. Form 1" flanges, fold over, and fasten with sheetmetal screws inside heater. Gain access to the unit by removing side panels from the blower and downturn plenum sections. Ducts must be attached and sealed to provide airtight connections.
- **Return Air Duct/Furnace Connection** - All return air ducts should be attached and sealed to return air flanges to provide airtight connection.
- **Return Air Duct/Grill Size** - Make certain that return air ducting or grills have a free area equal to the return duct size connection.

11. Gas Piping and Pressures

All piping must be in accordance with requirements outlined in the National Fuel Gas Code ANSI/Z223.1a (latest edition) or CAN/CGA-B149.1 and B149.2 (See Paragraph 1). Gas supply piping installation should conform with good practice and with local codes.

Duct furnaces for natural gas are orificed for operation with gas having a heating value of 1000 (+ or - 50) BTUH per cubic ft. If the gas at the installation does not meet this specification, consult the factory for proper orificing.

WARNING

This appliance is equipped for a maximum gas supply pressure of 1/2 pound, 8 ounces, or 14 inches water column. Supply pressure higher than 1/2 pound requires installation of an additional service regulator external to the unit.

PRESSURE TESTING SUPPLY PIPING

Test Pressures Above 1/2 PSI: Disconnect the heater and manual shutoff valve from the gas supply line which is to be tested. Cap or plug the supply line.

Test Pressures Below 1/2 PSI: Before testing, close the manual valve on the heater.

Gas Connection to Single-Stage Valve (Not Gas Supply Line Size)					
Size	Natural	Propane	Size	Natural	Propane
75-250	1/2"	1/2"	300-400	3/4"	1/2"

Pipe joint compounds (pipe dope) shall be resistant to the action of liquefied petroleum gas or any other chemical constituents of the gas being supplied.

Install a ground joint union and manual shutoff valve upstream of the unit control system, as shown in Figures 16 and 17. The 1/8" plugged tapping in the shutoff valve provides connection for supply line pressure test gauge. The National Fuel Gas Code requires the installation of a trap with a minimum 3" drip leg. Local codes may require a minimum drip leg longer than 3" (typically 6").

After all connections are made, disconnect the pilot supply at the control valve and bleed the system of air. Reconnect the pilot line and leak-test all connections by brushing on a soap solution.

WARNING: All components of a gas supply system must be leak tested prior to placing equipment in service. NEVER TEST FOR LEAKS WITH AN OPEN FLAME. Failure to comply could result in personal injury, property damage or death.

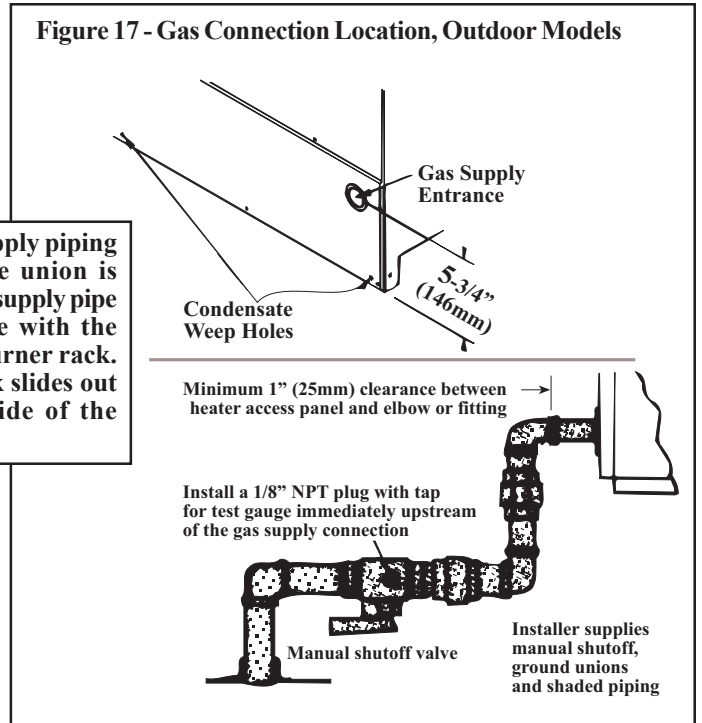
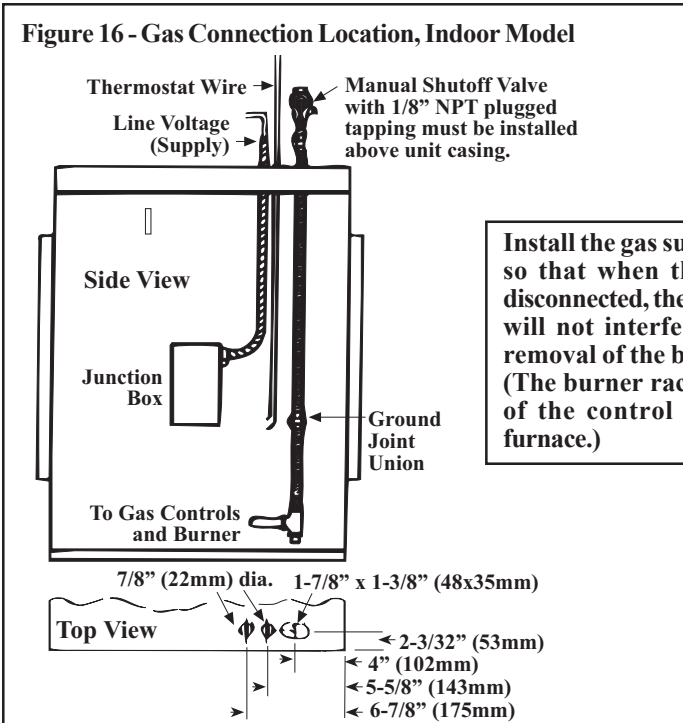

Install the gas supply piping so that when the union is disconnected, the supply pipe will not interfere with the removal of the burner rack. (The burner rack slides out of the control side of the furnace.)

Sizing Gas Supply Lines

Capacity of Piping												
Cubic Feet per Hour based on 0.3" w.c. Pressure Drop												
Specific Gravity for Natural Gas -- 0.6 (Natural Gas -- 1000 BTU/Cubic Ft)												
Specific Gravity for Propane Gas -- 1.6 (Propane Gas -- 2550 BTU/Cubic Ft)												
Length of Pipe	Diameter of Pipe											
	1/2"		3/4"		1"		1-1/4"		1-1/2"		2"	
	Natural	Propane	Natural	Propane	Natural	Propane	Natural	Propane	Natural	Propane	Natural	Propane
20'	92	56	190	116	350	214	730	445	1100	671	2100	1281
30'	73	45	152	93	285	174	590	360	890	543	1650	1007
40'	63	38	130	79	245	149	500	305	760	464	1450	885
50'	56	34	115	70	215	131	440	268	670	409	1270	775
60'	50	31	105	64	195	119	400	244	610	372	1105	674
70'	46	28	96	59	180	110	370	226	560	342	1050	641
80'	43	26	90	55	170	104	350	214	530	323	990	604
90'	40	24	84	51	160	98	320	195	490	299	930	567
100'	38	23	79	48	150	92	305	186	460	281	870	531
125'	34	21	72	44	130	79	275	168	410	250	780	476
150'	31	19	64	39	120	73	250	153	380	232	710	433
175'	28	17	59	36	110	67	225	137	350	214	650	397
200'	26	16	55	34	100	61	210	128	320	195	610	372

Note: When sizing supply lines, consider possibilities of future expansion and increased requirements. Refer to National Fuel Gas Code for additional information on line sizing.

11. Gas Pressures (cont'd)

Manifold or Orifice Pressure Settings

Measuring manifold gas pressure cannot be done until the heater is in operation. It is included in the "Check-Test-Start" section, Paragraph 28. The following instructions apply.

WARNING: Manifold gas pressure must never exceed 3.5" w.c. for natural gas and 10" w.c. for propane gas.

For Natural Gas: High fire manifold gas pressure is regulated by the combination valve to 3.5" w.c. Inlet pressure to the valve must be a minimum of 5" w.c. or **as noted on the rating plate** and a maximum of 14" w.c. **NOTE: Always check the rating plate for minimum gas supply pressure.** Minimum supply pressure requirements vary based on size of burner and gas control option. Most units require a minimum of 5" w.c. of natural gas as stated above, but Sizes 350 and 400 with electronic modulation require a minimum of 6" w.c. natural gas supply pressure. Sizes 300 and 350 with mechanical modulation require 7" w.c. **For Propane Gas:** High fire manifold gas pressure is regulated by the combination valve to 10" w.c. Inlet pressure to the valve must be a minimum of 11" w.c. and a maximum of 14" w.c.

Before attempting to measure or adjust manifold gas pressure, the inlet (supply) pressure must be within the specified range for the gas being used both when the heater is in operation and on standby. Incorrect inlet pressure could cause excessive manifold gas pressure immediately or at some future time.

Instructions to Check Manifold Pressure:

- 1) With the manual valve (on the combination valve) positioned to prevent flow to the main burners, connect a manometer to the 1/8" pipe outlet pressure tap in the valve. **NOTE:** A manometer (fluid-filled gauge) is recommended rather than a spring type gauge due to the difficulty of maintaining calibration of a spring type gauge.
- 2) Open the valve and operate the heater. Measure the gas pressure to the manifold. Normally adjustments should not be necessary to the factory preset regulator.

If adjustment is necessary, set pressure to correct settings by turning the regulator screw IN (clockwise) to increase pressure. Turn regulator screw OUT (counterclockwise) to decrease pressure. Consult the valve manufacturer's literature provided with the furnace for more detailed information.

12. Electrical Supply and Connections

All electrical wiring and connections, including electrical grounding **MUST** be made in accordance with the National Electric Code ANSI/NFPA No. 70 (latest edition) or, in Canada, the Canadian Electrical Code, Part I-C.S.A. Standard C22.1. In addition, the installer should be aware of any local ordinances or gas company requirements that might apply.

Check the rating plate on the heater for the supply voltage and current requirements. A separate line voltage supply with fused disconnect switch should be run directly from the main electrical panel to the furnace, making connection to leads in the junction box. All external wiring must be within approved conduit and have a minimum temperature rise of 60°C. Conduit from the disconnect switch must be run so as not to interfere with the service panels of the furnace.

CAUTION: If any of the original wire as supplied with the appliance must be replaced, it must be replaced with wiring material having a temperature rating of at least 105°C, except for blocked vent, energy cutoff, and sensor lead wires which must be 150°C. See Hazard Levels, page 2.

If the heater has field-installed options that require electrical connections, consult the instruction sheet and wiring diagram supplied in the option package. Specific wiring diagrams that include standard and factory-installed options are included with the heater. **Typical wiring diagrams are on pages 18-22.**

WARNING: If you turn off the power supply, turn off the gas. See Hazard Levels, page 2.

Disconnect Switch

A disconnect switch is a required part of this installation. Switches are available, as options or parts, or may be purchased locally. When ordered as an optional component, the disconnect switch is shipped separately.

The disconnect switch may be fusible or non-fusible. When providing or replacing fuses in a fusible disconnect switch, use dual element time delay fuses and size according to 1.25 times the maximum total input amps.

When installing, be careful that the conduit and switch housing are clear of furnace panels and inspection plates. Allow at least four feet of service room between the switch and removable panels. See Figure 18 for suggested locations.

Field-Supplied Wiring Size from Disconnect to Electrical Box for Connection to Motor Contactor or Starter

Voltage/Phase	Motor HP	Wire Gauge	BX Cable
120/1	1/4 - 1/2	14	3/8"
	1	12	3/8"
208-230/1	1 - 1.5	14	3/8"
208-230/3	1/4 - 3	14	3/8"
	5	12	3/8"
460/3	1/4 - 5	14	3/8"
575/3	1/2 - 5	14	3/8"

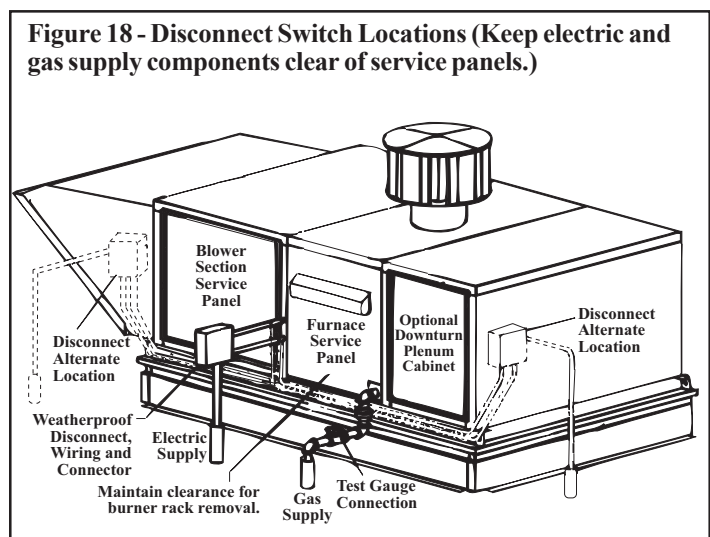

Convenience Outlet Option

When a convenience outlet option is included, an individual power supply must be provided to the receptacle. This circuit **MUST BE** on a ground fault breaker to meet requirements. All wiring to the convenience outlet must meet National Electrical Code ANSI/NFPA No. 70 (latest edition) and any local or utility codes that apply.

Figure 19 - Location of Standard and Optional Controls -- Outdoor Systems

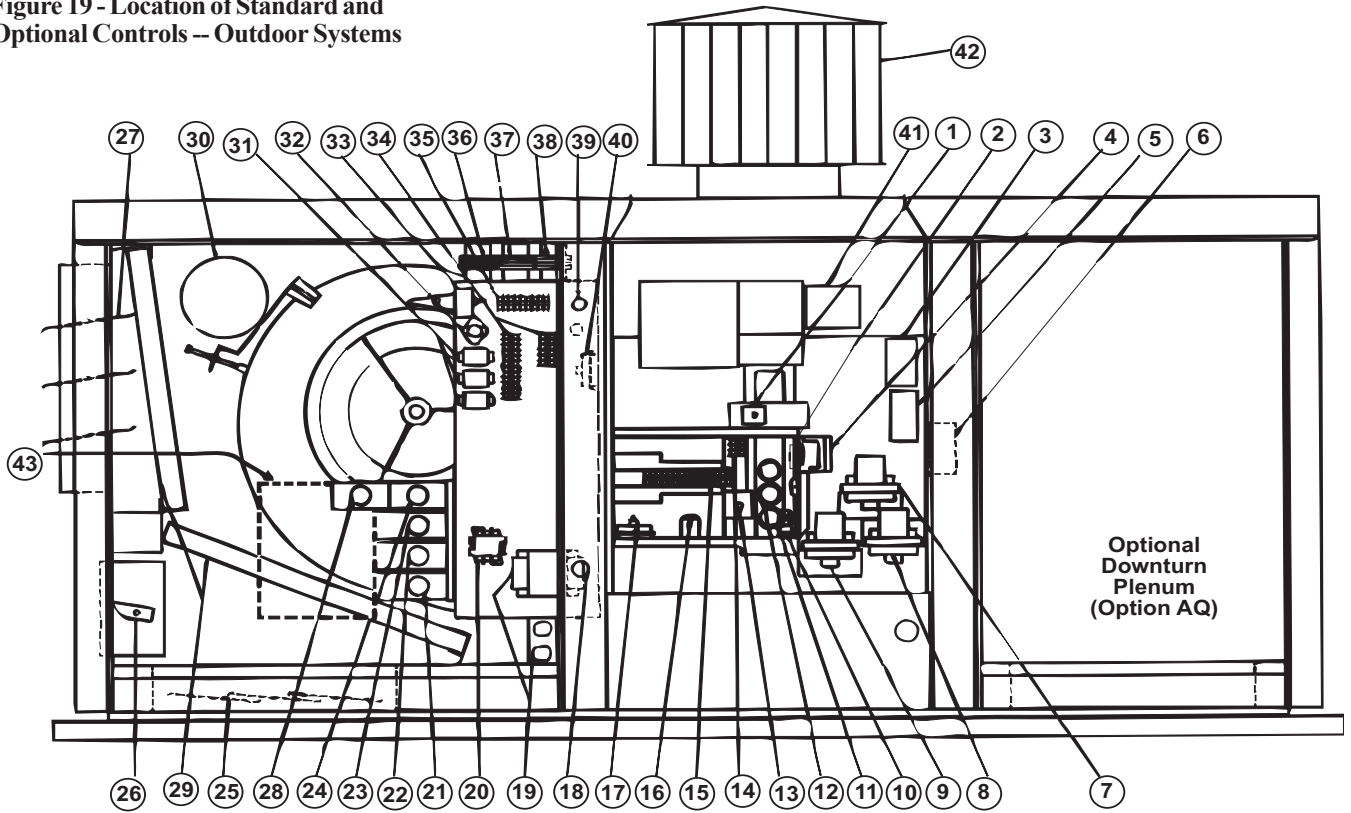

1. Optional Auto Reset Freezestat	10. Time Delay Relay (power-vented)	21. Optional High Ambient Limit Control	32. Auto Reset Reverse Flow Limit
2. Combustion Air Pressure Switch (power-vented)	11. Limit Control	22. Optional Outside Air or Return Air Controller	33. Optional Return Air Firestat
3. Optional Discharge Air Firestat	12. Fan Control	23. Optional Mixed Air Controller	34. Low Voltage Terminal Strip
4. Ignition Controller	13. Optional Freezestat Time Delay Relay	24. Optional Potentiometer	35. Line Voltage Terminal Strip
5. Optional Maxitrol Discharge Air Sensor (Opt AG8 or 9)	14. Line Voltage Terminal Block	25. Optional Return Air Dampers	36. Control Transformer
6. Optional Two-Stage Controller (Opt AG3) or Maxitrol Amplifier (Opt AG7, 8, or 9)	15. Low Voltage Terminal Block	26. Optional Two Position or Modulating Damper Motor	37. Control Transformer (as required)
7. Optional Main Low Gas Pressure Switch	16. Freezestat Relay	27. Optional Outside Air Damper	38. Optional Damper Motor Transformer
8. Optional Pilot High Gas Pressure Switch	17. Optional Dirty Filter Pressure Switch	28. Optional Potentiometer	39. Low Voltage Connection (field)
9. Optional Main High Gas Pressure Switch	18. Line Voltage Connection (field)	29. Optional Filters	40. Optional Air Proving switch
	19. Optional Convenience Outlet and Outlet Transformer	30. Blower Motor	41. Venter Assembly (power-vented)
	20. Blower Motor Contactor or Starter	31. Optional Control Relays (as required, 8 maximum)	42. Vent Cap (gravity-vented)
			43. Optional DDC interface Control

Thermostat & Other Optional Controls

A thermostat is not standard equipment but is an installation requirement. Use either an optional thermostat available with the system or a field-supplied thermostat. Install according to the thermostat manufacturer's instructions.

A 24 volt thermostat must be used to actuate low voltage gas controls. If line voltage from the thermostat to the unit is desired, consult the factory representative.

Thermostats should be located five feet above the floor on an inside wall, not in the path of warm or cold air currents and not in corners where air may be pocketed. Do NOT install on cold air walls. For specific connection details, refer to instruction packet with the thermostat.

CAUTION: Make sure the thermostat has an adequate VA rating for the total requirements. Add coil rating of all relays and match thermostat rating. See Hazard Levels, page 2.

24 Volt Controls - Maximum Amps

Single-Stage Valve - .6	Maxitrol System - .5
Fan Control Heater - .12	Relay Coil - .12
Two-Stage Valve - .6	Spark Ignition System - .1
Time Delay Relay Heater - .1	Motor Contactor Coil - .33

If more than one unit is cycled from one thermostat, separately activated relays must be substituted at unit thermostat connections.

There are a variety of optional controls available as part of the gas and air control options. Check the wiring diagram and literature supplied with the unit for operation of factory-installed optional controls. See Figure 19 for location of standard and optional controls on outdoor systems.

Optional shipped-separate heating and makeup air controls could include a single or two-stage thermostat, system switches, selectrastat, freezestat, an automatic night setback device, a Maxitrol temperature selector, a potentiometer, a pressure null switch, or a combination of these controls. Install controls according to the manufacturer's instructions packaged with the heater.

A selection of remote consoles are available with certain appropriate combinations of controls factory mounted. All consoles include indicator lights for the blower and burner, an off/on system switch, and terminal block wiring.

Typical Wiring Diagrams (Refer to the diagram supplied with the furnace for alternate controls or optional equipment details.)

Indoor, Gravity-Vented Furnace with Match-Lit Pilot and Standard Single-Stage Gas Valve

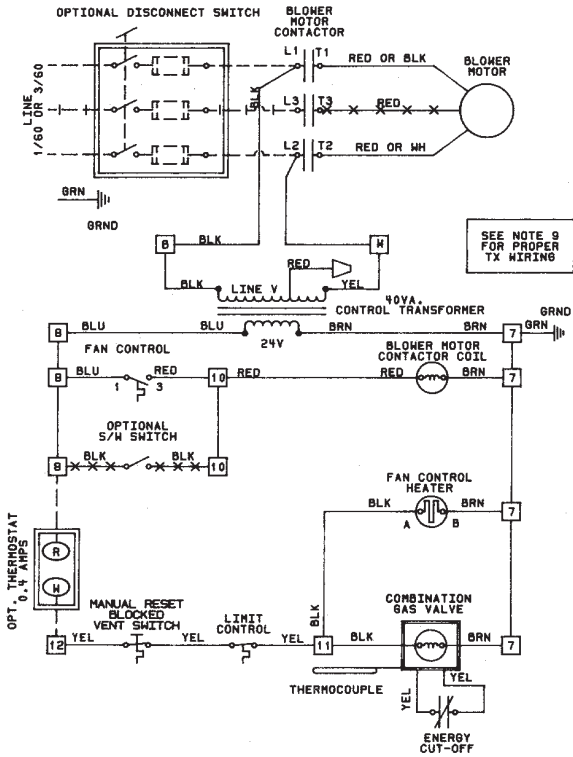

Indoor, Gravity-Vented Furnace with Optional Spark Ignition and Standard Single-Stage Gas Valve

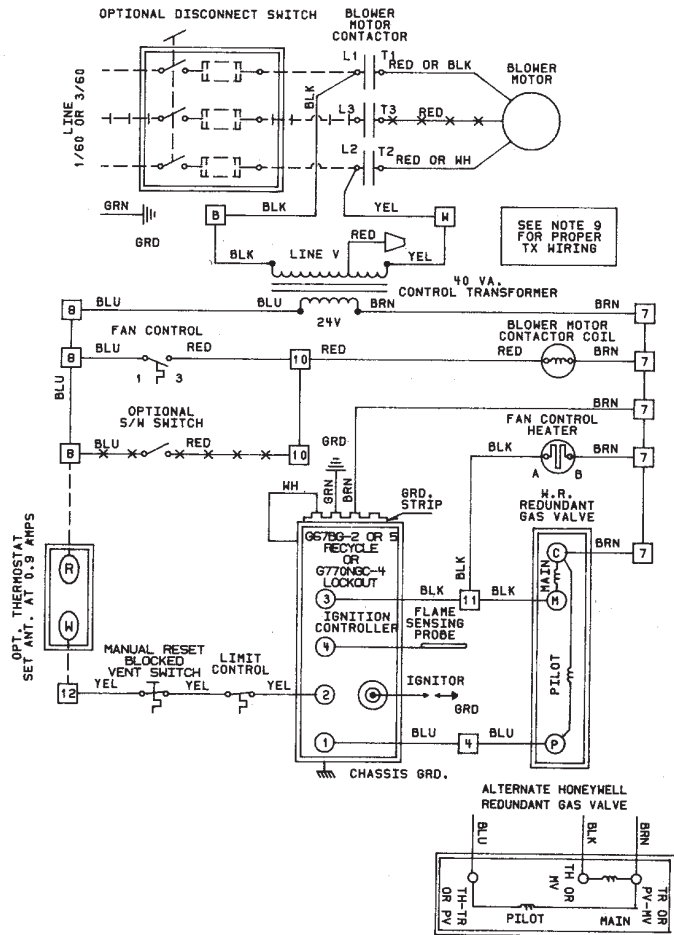

Field Control Wiring - Length and Gauge		
Total Wire Length	Distance from Unit to Control	Minimum Recommended Wire Gauge
150 ft (46M)	75 ft (23M)	#18 gauge
250 ft (76M)	125 ft (38M)	#16 gauge
350 ft (107M)	175 ft (53M)	#14 gauge

Wiring Notes

- The following controls are field installed options: Thermostat and Disconnect Switch
- Dotted wiring installed by others.
- CAUTION:** If any of the original wiring as supplied with the appliance must be replaced, it must be replaced with wiring material having a temperature rating of at least 105°C, except for energy cutoff, blocked vent switch, or sensor lead wiring which must be 150°C.
- Line and blower motor branch circuit wire sizes should be of a size to prevent voltage drops beyond 5% of supply line voltage.
- Use 14 Ga. wire for line wiring to the furnace.
- Use 12 Ga. wire for line and motor wiring on single phase unit (1HP or less).
- Use 10 GA. wire for line and motor wiring on single phase unit (1-1/2HP).
- Use 18 Ga. wire for 24 volt control wiring on the furnace.
- On 208-230V units, the control transformer has a dual voltage primary. For 230V units, use black and yellow leads (cap red). For 208V units, use black and red leads (cap yellow). On 115V or 460V units, the control transformer is a single voltage primary. For 115V or 460V units, use black and yellow leads. Secondary side of all transformers (24V), use blue and brown leads.

Typical Wiring Diagrams (cont'd)

Outdoor, Gravity-Vented Furnace with Standard Single-Stage Gas Valve

Operating Sequence -

1. Set the thermostat at its lowest setting.
2. Turn on power and manual gas valve to unit.
3. Set thermostat at desired setting.
 - a) Firing rate is controlled by the single-stage thermostat.
 - b) Blower motor operates from heat exchanger temperature.

Firing Sequence -

1. On call for heat by the thermostat.
2. The pilot gas valve and spark gap are energized to produce a pilot flame on each operating cycle. The sensing probe proves the presence of the pilot flame and energizes the safety switch portion of the control. The switch action de-energizes the spark gap and energizes the main valve. The main gas ignites and the unit fires at full rate.
3. If the flame is extinguished during main burner operation, the safety switch closes the main valve and re-cycles the spark gap. On units equipped with the G770NG-4 lockout control, if pilot is not established

within 120 seconds (approx.), unit locks out and must be reset by interrupting power to the control circuit (see Lighting Instructions.).

Wiring Notes

1. The following controls are factory supplied for field installation: None
 2. The following controls are field installed options: Thermostat & Disconnect Switch
 3. Dotted wiring installed by others.
 4. **CAUTION:** If any of the original wiring as supplied with the appliance must be replaced, it must be replaced with wiring material having a temperature rating of at least 105°C, except for sensor lead wiring which must be 150LC.
 5. Line and blower motor branch circuit wire sizes should be of a size to prevent voltage drops beyond 5% of supply line voltage.
 6. Use 14 Ga. wire for line and motor wiring on 3-phase unit.
 7. Use 12 Ga. for line and motor wiring on single phase unit.
 8. Use 18 Ga. wire for 24 volt control wiring on the furnace.
 9. On 208-230V units, the control transformer has a dual voltage primary.
 - For 230V units, use black and yellow leads (cap red)
 - For 208V units, use black and red leads (cap yellow)
- On 115V or 460V units, the control transformer is a single voltage primary.
 For 115V or 460V units, use black and yellow leads.
 Secondary side of all transformers (24V), use blue and brown leads.

Field Control Wiring - Length and Gauge		
Total Wire Length	Distance from Unit to Control	Minimum Recommended Wire Gauge
150 ft (46M)	75 ft (23M)	#18 gauge
250 ft (76M)	125 ft (38M)	#16 gauge
350 ft (107M)	175 ft (53M)	#14 gauge

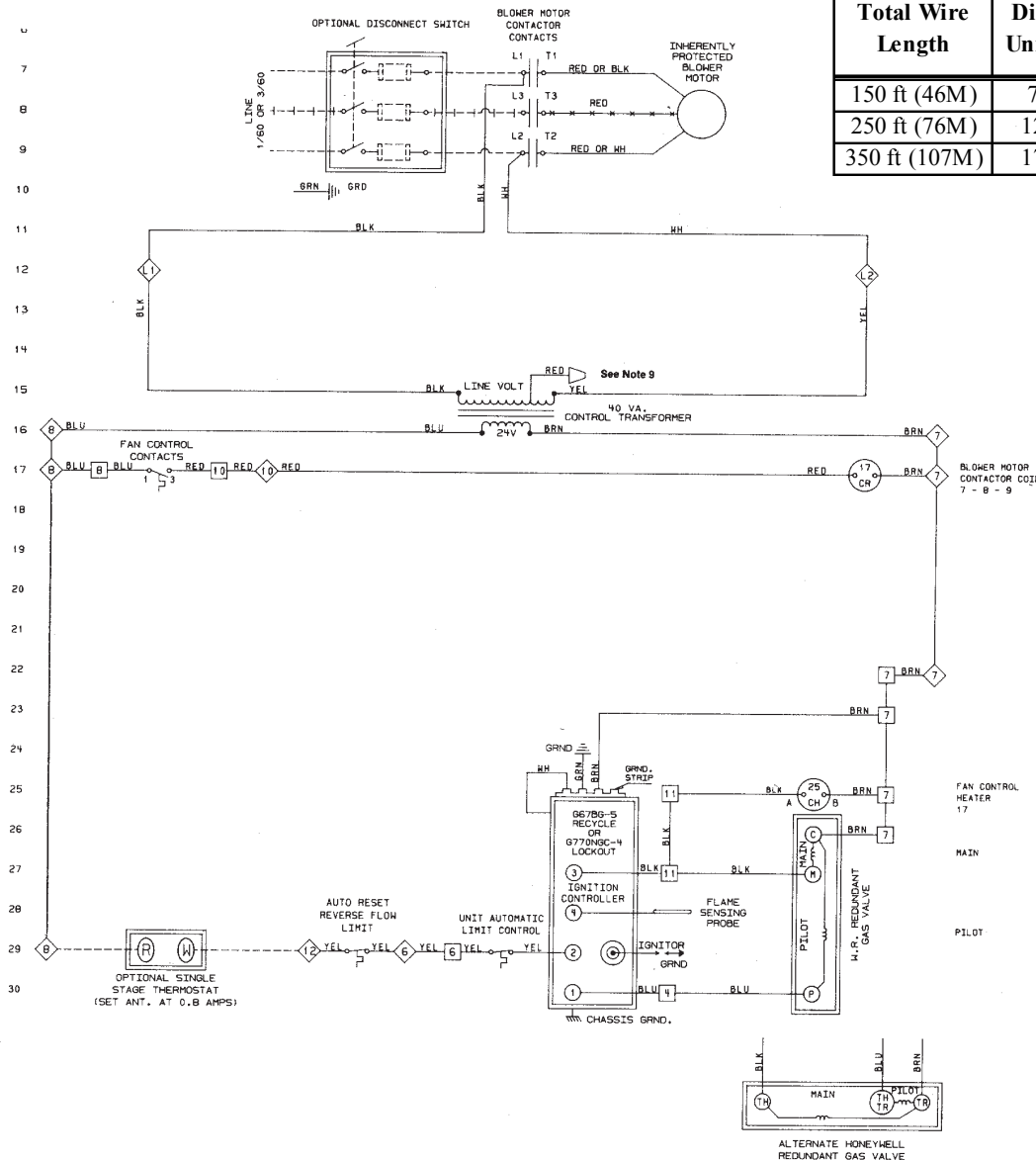

W.D. 106902

Outdoor, Power-Vented Furnace with Standard Single-Stage Gas Valve

Operating Sequence -

1. Set the thermostat at lowest setting.
2. Turn on power and manual gas valve.
3. Set thermostat at desired setting.
- (a) Firing rate is controlled by the single stage thermostat
- (b) Blower motor operates from the exchanger temperature

Firing Sequence

1. On a call for heat by the thermostat, the venter motor is energized after a 15 second (approx.) delay
2. Venter flow switch switches from N.C. to N.O. contacts, energizing the pilot gas valve and spark gap to produce a pilot flame on each operating cycle. The sensing probe proves the presence of the pilot flame and energizes the safety the safety switch portion of the control. The switch action de-energizes the spark gap and energizes the main valve. The main gas ignites and the unit fires at full rate.

NOTE: If the flame is extinguished during main burner operation, the safety switch closes the main valve and recycles the spark gap. On units equipped with the G770NG-4 lockout control, if pilot is not established within 120 seconds (approx.), unit locks out and must be reset by interrupting power to the control circuit (see Lighting Instructions).

Wiring Notes

1. The following controls are factory supplied for field installation: None
2. The following controls are field installed options: Thermostat and Disconnect Switch
3. Dotted wiring installed by others.
4. **CAUTION:** If any of the original wiring as supplied with the appliance must be replaced, it must be replaced with wiring material having a temperature rating of at least 105°C, except for sensor lead wiring which must be 150°C.
5. Line and blower motor branch circuit wire sizes should be of a size to prevent voltage drops beyond 5% of supply line voltage.
6. Use 18 Ga. wire for 24 volt control wiring on the furnace.
7. Use 14 Ga. wire for line and motor wiring on 3-phase unit.
8. Use 12 Ga. wire for line and motor wiring on single-phase unit.
9. On 208-230V units, the control transformer has a dual voltage primary.

For 230V units, use black and yellow leads (cap red)

For 208V units, use black and red leads (cap yellow)

On 115V or 460V units, the control transformer is a single voltage primary.

For 115V or 460V units, use black and yellow leads.

Secondary side of all transformers (24V), use blue and brown leads.

Field Control Wiring - Length and Gauge		
Total Wire Length	Distance from Unit to Control	Minimum Recommended Wire Gauge
150 ft (46M)	75 ft (23M)	#18 gauge
250 ft (76M)	125 ft (38M)	#16 gauge
350 ft (107M)	175 ft (53M)	#14 gauge

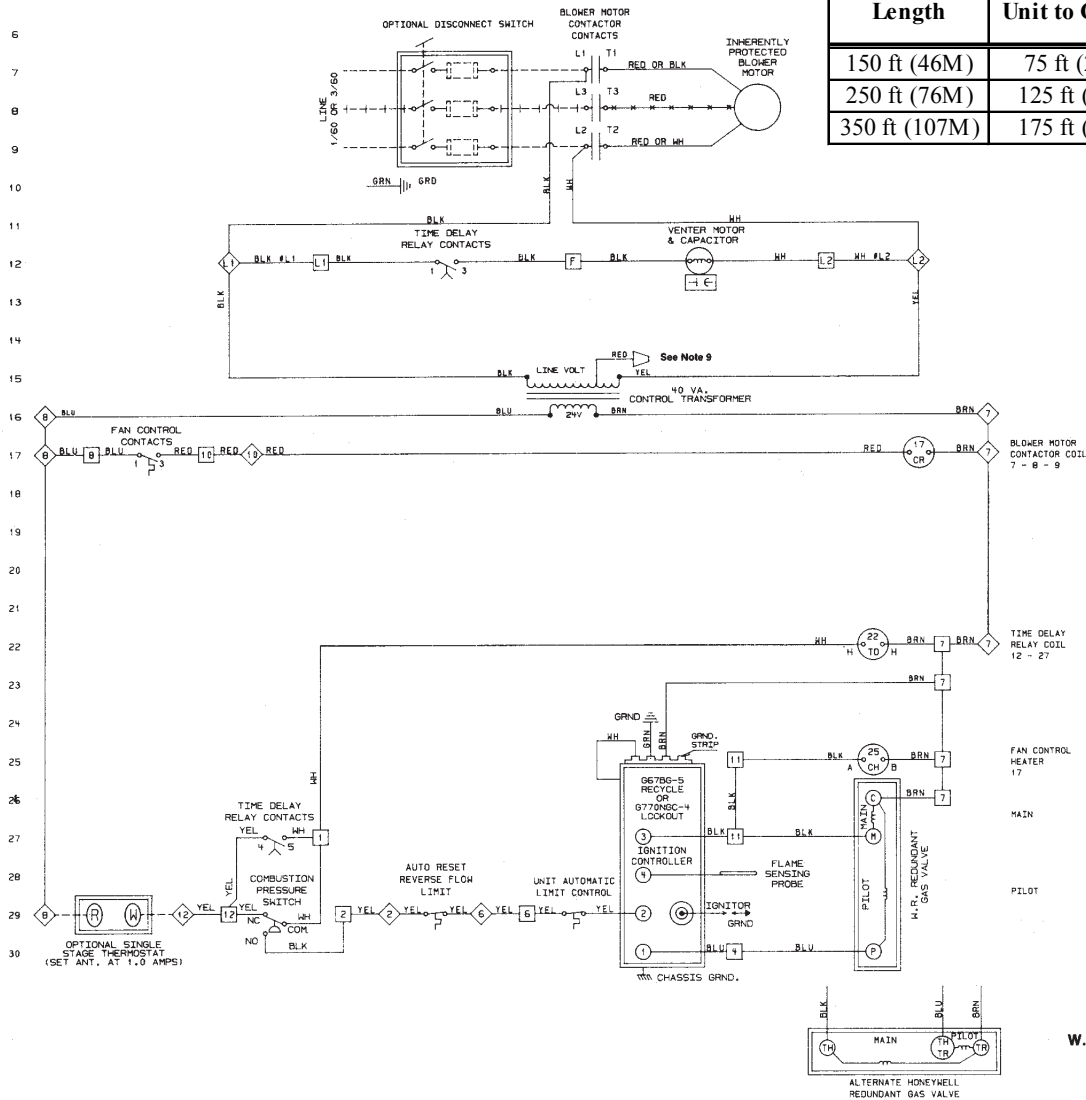

W.D. 106912

Typical Wiring Diagrams (cont'd)

Outdoor, Gravity-Vented Furnace with Optional Two-Stage Gas Valve

Operating Sequence -

1. Set control switch at "off" position.
2. Turn on power and manual gas valve.
3. Set control switch at "on" position.

(a) Energizing the blower motor.

(b) Firing rate is controlled by the two-stage temperature controller (with bulb in discharge air) and the two-stage overriding thermostat.

4. Set control switch at "off" position for shut-down. Fan control keeps blower motor on while unit is hot.

Firing Sequence

1. On a call for heat by the low stage of controller or thermostat, the pilot gas valve and spark gap are energized to produce a pilot flame on each operating cycle. The sensing probe proves the presence of the pilot flame and energizes the safety switch portion of the control. The switch action de-energizes the spark gap and energizes the main valve. The main gas ignites and the unit fires at low rate.
2. On call for heat by the high stage of controller or thermostat, unit fires at full rate.

NOTE: If the flame is extinguished during

main burner operation, the safety switch closes the main valve and recycles the spark gap. On units equipped with the G770NG-4 lockout control, if pilot is not established within 120 seconds (approx.), unit locks out and must be reset by interrupting power to the control circuit (see Lighting Instructions).

Wiring Notes

1. The following controls are supplied for field installation: Control Switch
2. The following controls are field installed options: Thermostat and Disconnect Switch
3. Dotted wiring installed by others.
4. **CAUTION:** If any of the original wiring as supplied with the appliance must be replaced, it must be replaced with wiring material having a temperature rating of at least 105°C, except for sensor lead wiring which must be 150°C.
5. Line and blower motor branch circuit wire sizes should be of a size to prevent voltage drops beyond 5% of supply line voltage.
6. Use 14 Ga. wire for line and motor wiring on 3-phase unit
7. Use 12 Ga. wire for line and motor wiring on single phase unit.
8. Use 18 Ga. wire for 24 volt control wiring on the furnace.
9. On 208-230V units, the control transformer has a dual voltage primary.

For 230V units, use black and yellow leads (cap red)

For 208V units, use black and red leads (cap yellow)

On 115V or 460V units, the control transformer is a single voltage primary. Use black and yellow leads for primary voltage.

Secondary side of all transformers (24V), use blue and brown leads.

Field Control Wiring - Length and Gauge		
Total Wire Length	Distance from Unit to Control	Minimum Recommended Wire Gauge
150 ft (46M)	75 ft (23M)	#18 gauge
250 ft (76M)	125 ft (38M)	#16 gauge
350 ft (107M)	175 ft (53M)	#14 gauge

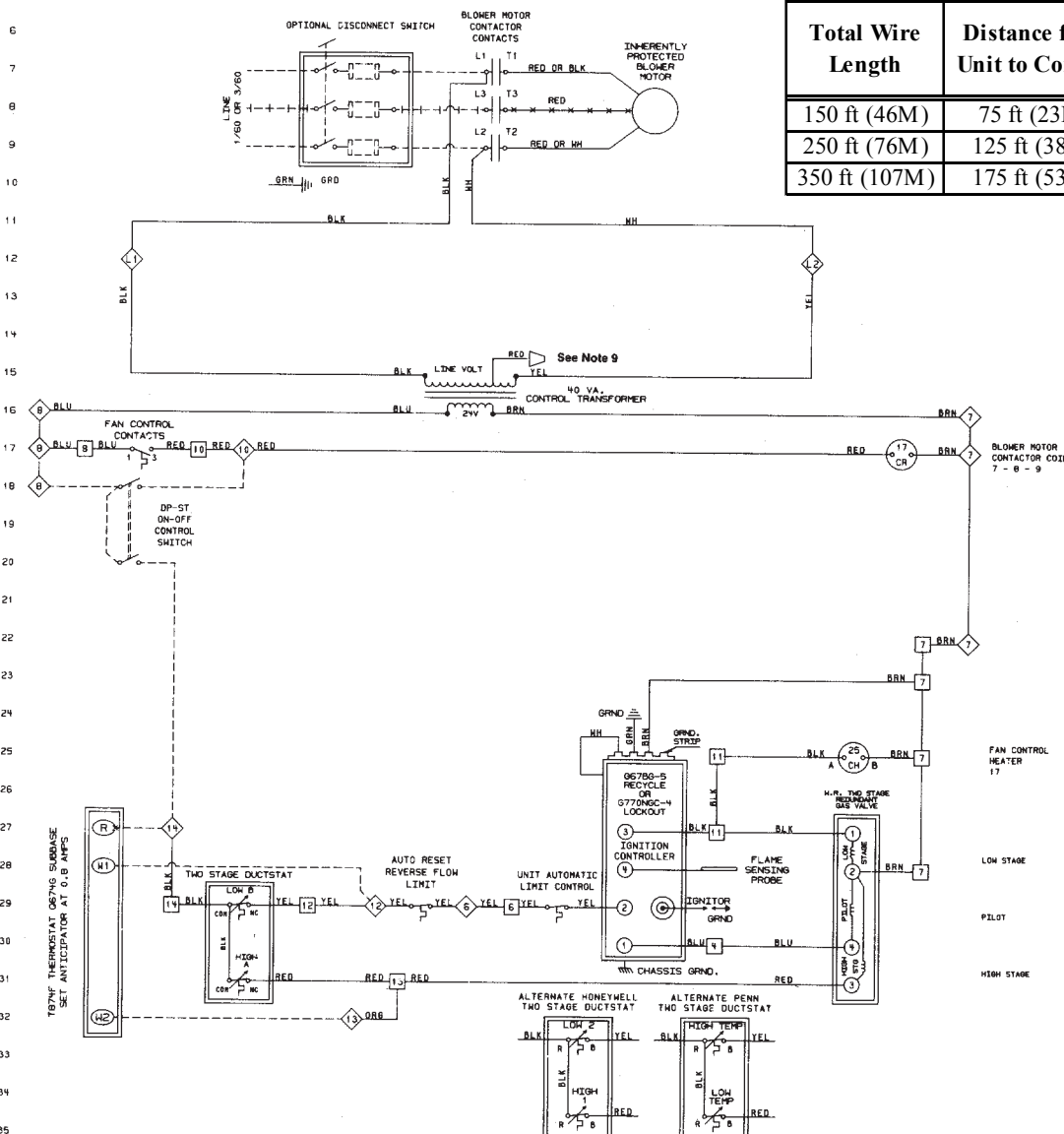

Outdoor, Power-Vented Furnace with Optional Two-Stage Gas Valve

Operating Sequence -

1. Set the control switch at "off" position.
2. Turn on power and manual gas valve.
3. Set control switch at "on" position.

(a) Energizing the blower motor.

(b) Firing rate is controlled by the two-stage temperature controller (with sensor in discharge air) and the two stage overriding thermostat.

4. Set control switch at "off" position for shutdown. Fan control keeps blower motor while unit is hot.

Firing Sequence

1. On a call for heat by the low stage controller or thermostat.

(a) The venter motor is energized after a 15 second (approximate) time delay.

(b) Venter flow switches from N.C. to N.O. contacts, energizing the pilot gas valve and spark gap to produce a pilot flame on each operating cycle. The sensing probe proves the presence of the pilot flame and energizes the safety switch portion of the control. The switch action de-energizes the spark gap and energizes the main

valve. The main gas ignites and the unit fires at low fire. **NOTE:** If the flame is extinguished during main burner operation, the safety switch closes the main valve and recycles the spark gap. On units equipped with the G770NG-4 lockout control, if pilot is not established within 120 seconds (approx.), unit locks out and must be reset by interrupting power to the control circuit (see Lighting Instructions).

2. On call for heat by the high stage of thermostat, the unit fires at full rate.

Wiring Notes

1. The following controls are supplied for field installation: Control Switch
2. The following controls are field installed options: Thermostat and Disconnect Switch
3. Dotted wiring installed by others.
4. **CAUTION:** If any of the original wiring as supplied with the appliance must be replaced, it must be replaced with wiring material having a temperature rating of at least 105°C, except for sensor lead wiring which must be 150°C.
5. Line and blower motor branch circuit wire sizes should be of a size to prevent voltage drops beyond 5% of supply line voltage.
6. Use 14 Ga. wire for line and motor wiring on 3-phase unit
7. Use 12 Ga. wire for line and motor wiring on single phase unit.
8. Use 18 Ga. wire for 24 volt control wiring on the furnace.
9. On 208-230V units, the control transformer has a dual voltage primary.

For 230V units, use black and yellow leads (cap red)

For 208V units, use black and red leads (cap yellow)

On 115V or /460V units, the control transformer is a single voltage primary. Use black and yellow leads for primary voltage.

Secondary side of all transformers (24V), use blue and brown leads.

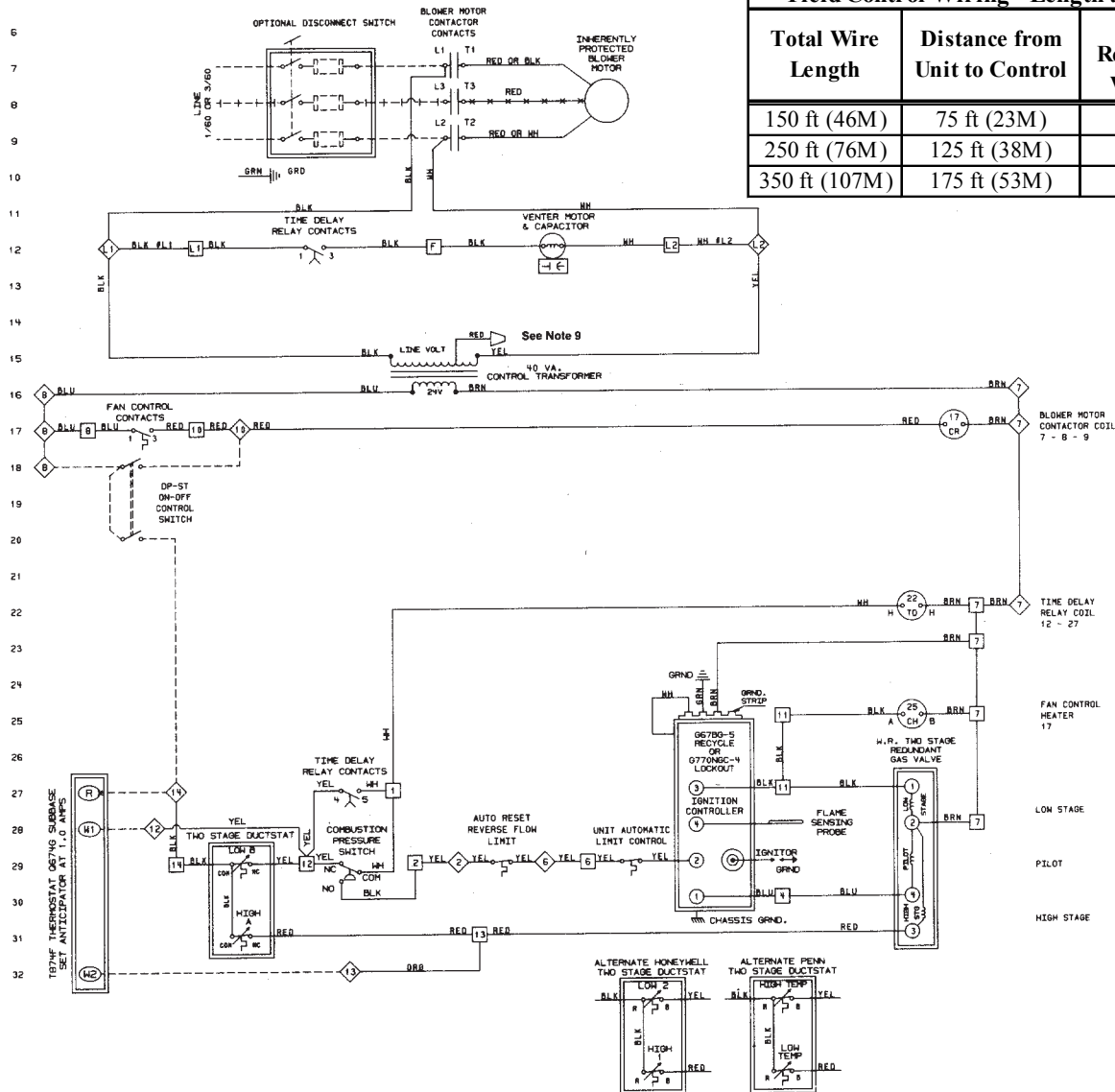

Field Control Wiring - Length and Gauge		
Total Wire Length	Distance from Unit to Control	Minimum Recommended Wire Gauge
150 ft (46M)	75 ft (23M)	#18 gauge
250 ft (76M)	125 ft (38M)	#16 gauge
350 ft (107M)	175 ft (53M)	#14 gauge

W.D. 106915

13. Blowers, Belts and Drives

Check belt tension. Proper belt tension is important to the long life of the belt and motor. A loose belt will cause wear and slippage. Too much tension will cause excessive motor and blower bearing wear.

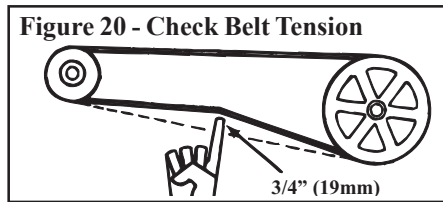

Adjust the belt tension by turning the adjusting screw on the motor base until the belt can be depressed 3/4". (See Figure 20.) After correct tension is achieved, re-tighten the locknut on the adjustment screw. Be sure that the belt is aligned in the pulleys.

Adjusting Blower Speed

The blower speed may be adjusted to achieve the desired outlet temperature, as long as the adjustment is within the temperature rise and the static pressure limits shown on the furnace rating plate. Motors are factory set between maximum and minimum blower speeds.

If the duct resistance is low, the blower may deliver too high an air volume. If the resistance is very low, the blower may deliver excess air to overload the motor, causing the overload protector to cycle the motor. Reducing the blower speed will correct these conditions. If ductwork is added to an installation, it may be necessary to increase the blower speed. Decreasing blower speed will increase outlet temperature; increasing blower speed will decrease outlet temperature.

At final adjustment, amperes should not exceed motor nameplate amp rating. The installation must be adjusted to obtain a temperature rise within the range specified on the furnace rating plate.

The belt drive on these units is equipped with an adjustable pulley which permits adjustment of the blower speed. Follow these instructions to adjust the blower speed.

1. Turn off the gas and the electric power.
2. Loosen belt tension and remove the belt.
3. Loosen the set screw on the side of the pulley away from the motor.
4. **To increase the blower speed, decreasing outlet temperature, turn the adjustable half of the pulley inward. To decrease the blower speed, increasing the outlet temperature, turn the adjustable half of the pulley outward.** One turn of the pulley will change the speed 8-10%.
5. Tighten the set screw on the flat portion of the pulley shaft.
6. Replace the belt and adjust the belt tension. Adjust tension by turning the adjusting screw on the motor base until the belt can be depressed 3/4" (Figure 20.) Re-tighten the lock nut on the adjusting screw. Be sure that the belts are aligned in the pulley grooves properly and are not angled from pulley to pulley.
7. Turn on the gas and electric. Light the heater following the instructions on the lighting instruction plate.
8. Check the motor amps with an amp meter. The maximum motor amp rating on the motor nameplate must not be exceeded.

When service is complete, check for proper operation.

Blower Rotation

Each blower housing is marked for proper rotation. Rotation may be changed on single-phase motors by re-wiring in the motor terminal box. Three-phase motors may be reversed by interchanging two wires on the 3-phase supply connections.

Optional Air Flow Proving Switch (Makeup Air only) - Outdoor Models with Option BW1

The optional air flow proving switch ensures that the circulating air blower is functionally providing an adequate amount of air flow prior to the unit being fired. The switch is a single pole/normally open device which closes when an increase in pressure, above the setpoint, is sensed in the circulating air blower. The switch is located in the blower junction box. (See Figure 19, Item 40).

Contacts are set to close at .10" w.c. (+.05" or -.02" w.c.).

14. Blower Motors

Use an amp meter to check motor amps. The following chart lists full load amps for various HP's and voltages. Amps may be adjusted downward by reducing blower RPM or increasing duct system static pressure.

This chart can be used for sizing line wiring but should not be interpreted as the exact motor amps. See the motor rating plate for exact motor specifications.

Full Load Amps - Blower Motors (Open)									
(Single Speed- Average Values)									
HP	1/4	1/3	1/2	3/4	1	1-1/2	2	3	5
115V 1PH	5.1	5.5	8.8	11.0	13.0	15.0	20.4	24.8	N/A
208V 1PH	2.1	3.2	5.1	6.3	7.5	8.3	11.3	14.0	28.0
230V 1PH	2.3	2.8	4.4	5.5	6.5	7.5	10.2	12.4	26.0
208V 3PH	1.1	1.4	2.3	2.9	3.7	5.6	7.0	9.0	13.4
230V 3PH	1.4	1.6	2.0	2.6	3.2	5.0	6.6	8.6	13.2
460V 3PH	.75	.80	1.0	1.3	1.6	2.7	3.5	4.3	6.6
575V 3PH	N/A	N/A	N/A	N/A	1.1	1.6	2.1	3.6	5.4

WARNING: If you turn off the power supply, turn off the gas. See Hazard Levels, page 2.

15. Fan Control

1. The fan control provides the following:
 - (a) A 45-second delay of blower operation to prevent the discharge of cold air.
 - (b) Blower operation as long as the unit is hot.
2. The fan control provides additional safety by keeping the blower in operation in the event that the gas valve fails to close when the thermostat is satisfied.
3. To be sure that the blower can continue to operate, the power supply to the furnace **MUST NOT** be interrupted **except** when servicing the unit.
4. If the customer wants the furnace off at night, the gas valve circuit **should be opened** by a single pole switch wired in series with the thermostat. Some thermostats are provided with this feature. Multiple units controlled from a single thermostat are shut off in the same manner. For proper operation, be sure the fan control wiring is observed.

The fan control contains a built-in heater to control delay times. For proper operation, refer to the wiring diagram furnished with the furnace. For location, see Figure 19, Item 12.

16. Limit Controls

16A. Limit and Energy Cutoff Controls - Indoor Models with Match-Lit Pilot

Indoor systems with a standard match-lit pilot are equipped with an automatic reset high limit control and are also equipped with a fusible link in the thermocouple circuit which acts to cause safety pilot drop out in case of limit control malfunction or failure of the blower motor in combination with the automatic valve failing to close. This ECO control acts as a super high limit providing redundant safety control and is calibrated to open at a much higher temperature than the standard automatic reset limit.

WARNING: An ECO circuit interruption is a major failure caused by a malfunction of the primary safety controls or miswiring, and will require correction of the cause of failure and the replacement of the fan and limit control and wiring before the unit can be returned to service. See Hazard Levels, page 2.

16. Limit Controls (cont'd)

An ECO fusible link interruption can be caused by the following combination of failures:

1. Automatic gas valve stuck in open position.
2. Restricted air flow over heat exchanger due to motor failure, broken blower belt, or defective fan control.
3. Ruptured gas pressure regulator.
4. Improper wiring.

16B. Limit Control - All Models with Spark Pilot

The heater is equipped with a non-adjustable high limit switch which shuts off the gas in the event of motor failure, lack of air due to dirty filters, or restrictions at the inlet or outlet of the unit. See Paragraph 28 for limit control check. For location, see Figure 19, Item 11.

17. Blocked Vent Switch (indoor systems)

The blocked vent switch is a heat-activated, manually reset, safety device that interrupts the electric supply to the gas valve when the vent is 100% blocked. The sensor is located near the relief opening of the draft hood; the reset button is inside the control compartment by the draft hood side.

If the sensor detects heated flue gases in the draft hood relief opening area, the blocked vent safety device will activate to shut down the furnace. The cause for the switch shutting down the furnace must be determined and corrected. The blocked vent switch is designed to activate when the vent is blocked but may also be affected by a negative building pressure or an inadequate vent system.

After the problem has been corrected, remove the furnace control side panel and push the manual reset button on the blocked vent switch to restart the furnace. Replace control panel.

WARNING: In the event the blocked vent sensor causes the furnace to shut off, determine and correct the cause. Failure to do so could result in personal injury or death.

NOTE: Effective April 1991, this model of indoor, gravity-vent furnaces is equipped with a blocked vent shut-off system. These units manufactured prior to April 1991 do not include the blocked vent switch.

18. Reverse Flow, Limit Control (Outdoor Models)

These outdoor furnaces are factory equipped with an automatic reset reverse flow limit control. This control is located in the blower compartment, mounted in the blower junction box adjacent to the blower inlet opening, and is wired in series with the main limit control mounted on the heat exchanger duct side. For location, see Figure 19, Item 32.

In case of belt breakage or motor failure, the limit control will be opened by the high temperatures caused by reverse flow from the heat exchanger to the blower compartment, thus breaking the circuit to the automatic electric gas valve and preventing burner operation.

19. Combustion Air Proving Switch (Power-Vented Models)

The combustion air proving switch ensures that proper combustion air flow is available. The switch is a single-pole, double-throw switch, which senses pressure caused by the flow of combustion air from the venter. The switch is designed to close when a decreasing pressure is sensed in the outlet duct of the gas collection box. For location, see Figure 19, Item 2.)

On start-up when the furnace is cold, the sensing pressure is at the most negative level, and as the furnace and the flue system warm-up, the sensing pressure becomes less negative. After the system has reached equilibrium (approximately 20 minutes), the sensing pressure levels

Form RZ 403, Mfg No. 131782, Page 24

off. If a restriction or excessive flue length or turns cause the sensing pressure to become less than the switch setpoint, the pressure switch will function to shut off the main burners. The main burners will remain off until the system has cooled and/or the flue system resistance is reduced. The table below gives approximate water column negative pressure readings and switch setpoints for sea level operating conditions.

Startup Cold	Equilibrium	Factory Setpoint
-1.05" w.c.	-.73" w.c.	-.58 +or- .05" w.c.

DANGER: Safe operation requires proper venting flow. Never bypass the combustion air proving switch or attempt to operate the unit without the venter running and proper flow in the vent system. Hazardous condition could result. See Hazard Levels, page 2.

20. Optional High Ambient Limit Control (Outdoor Models)

The optional high ambient limit control functions to shutoff the burner when the entering outside air reaches a set temperature. The temperature setting is field adjustable from 0-100°F. For location, see Figure 19, Item 21.

21. Operating Valve

All furnaces are equipped with a 24-volt combination valve which includes the automatic electric on-off valve controlled by the room thermostat, the pressure regulator, the safety pilot valve, and the manual shutoff valve. The standard gas valve allows for single-stage control from a single-stage, 24-volt thermostat.

WARNING: The operating valve is the prime safety shutoff. All gas supply lines must be free of dirt or scale before connecting the unit to ensure positive closure. See Hazard Levels, page 2.

22. Optional 2-Stage Operation - Heating Only Application

The standard combination control valve is replaced with a two-stage combination gas control valve providing for low fire or high fire operation controlled by a two-stage thermostat. First stage (low fire) is factory set (not field adjustable). Both high and low stages are controlled by a Servo regulator, maintaining constant gas input under wide variations in gas supply pressure. See instructions packed with the unit for specific gas valve specifications, wiring, and operating instructions.

23. Optional 2-Stage Operation - Makeup Air Application

Two-stage makeup air units are equipped with a two-stage gas valve, but instead of control from a two-stage room thermostat, the outlet air temperature is monitored and controlled by a two-stage ductstat. When the discharge air temperature drops to the setpoint, low fire is energized. If low fire cannot satisfy the ductstat setting, high fire is energized.

Makeup air applications are usually adjusted to discharge an outlet air temperature between 65°F and 75°F. In all applications, the allowable temperature rise of the furnace in the installation dictates the limits of the ductstat temperature setting.

Depending on the option selection, the factory-installed sensor is either field-connected by capillary tubing to the unit-mounted ductstat (Figure 21) or electrically connected to a remote electronic temperature selector (Figure 22). The remote temperature selector is available with or without a display module.

See Figure 23 for a general location of the factory-installed sensor with either the factory-mounted or the remote ductstat selector option.

Optional Ductstat with Capillary Tubing (Option AG3) -- Either of the controls illustrated in Figure 21 is used with Option AG3. The control is set to 70°F and has an adjustable range with a fixed differential of 2-1/2°F. Due to different CFM settings and outside air temperatures, the average downstream outlet temperature may not match the ductstat setting exactly. After the installation is complete, adjust the setpoint of the ductstat to achieve the desired average outlet air temperature.

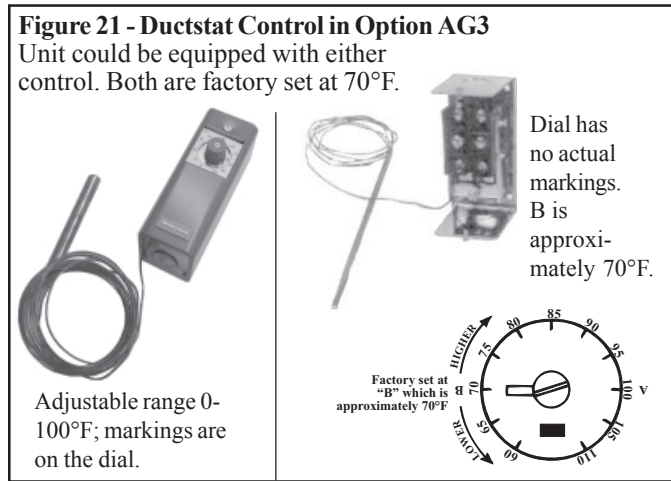

Optional Ductstat with Electronic Remote Setpoint Module (Options AG15 and AG16) -- The field-installed sensing probe is field-wired to a remote temperature selector with a temperature operating range to 130°F. The remote modules and sensing probe are shipped separately for field installation. Follow the wiring diagram with the unit and the manufacturer's instructions for wiring and installation. **CAUTION:** Be sure heat/cool selector switch is set at "Heat" position. There will be one module for selecting temperature and one stage-adder module. The digital display module is optional. See Figure 22.

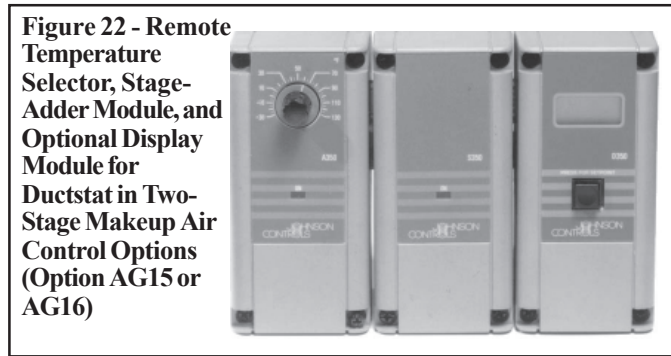

24. Optional Mechanical Modulation - Makeup Air Application

The mechanical modulation valve regulates the flow of gas to the main burner, depending on the demands of the sensing bulb which is located in the airstream adjacent to the heat exchanger. Inputs are varied from 50% through 100% of full rate in direct response to the modulating control sensing element and depending on the temperature of outside air being forced through the furnace. Outlet air or return air temperature can be maintained within a range of 50°F to 100°F and is adjustable at the mechanical modulating valve.

On outdoor models, mechanical modulation gas control is available with bypass. With the bypass option, the unit is equipped with a single-stage valve and relay. On call from a remote override thermostat, the single-stage bypass valve cycles on at 100% fire.

Optional mechanical modulation control without bypass is identified as Option AG6; mechanical modulation control with bypass is Option AG13.

Specifications and operating instructions for mechanical modulating valve may be found in control manufacturer's Specifications and Oper-

ating Sheet in the instruction envelope accompanying the furnace. (See Figure 23 for a general location of the factory-installed sensor.)

Installation NOTE: Sizes 300 and 350 with mechanical modulation require a minimum of 7" w.c. natural gas supply pressure.

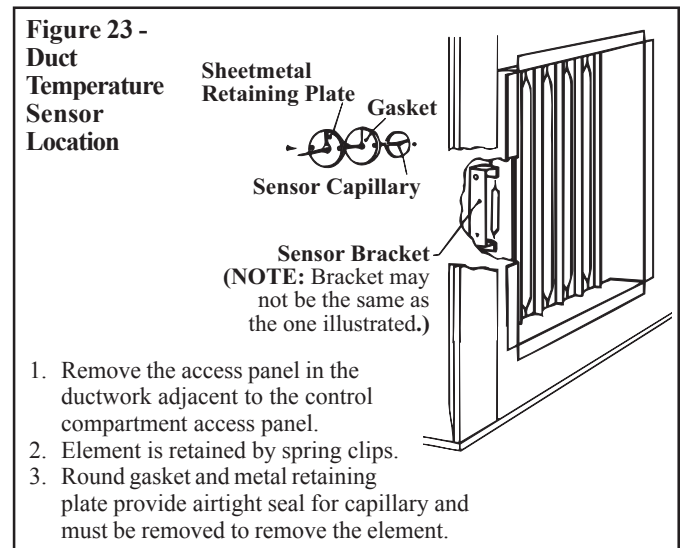

25. Optional Electronic Modulation

The type and capability of the electronic modulation system, depends on the option selected. Electronic modulation options are identified by a suffix to the Serial No. printed on the heater rating plate. AG7 is identified as MV-1; AG8 is identified as MV-3; AG9 is identified as MV-4; AG21 is identified as MV-A; AG39 is identified as MP-1; and AG40 is identified as MP-2.

Installation NOTE: Sizes 350 and 400 with electronic modulation require a minimum of 6" w.c. natural gas supply pressure.

25A. Electronic Modulation between 50% and 100% Firing Rate (Options AG7, AG8, AG9)

Depending on the heat requirements as established by the thermistor sensor, the burner modulates between 100% and 50% firing. The thermistor is a resistor that is temperature sensitive in that as the surrounding temperature changes, the Ohms resistance changes through the thermistor. This change is monitored by the solid state control center (amplifier) which furnishes varying DC current to the modulating valve to adjust the gas input.

Each modulating valve is basically a regulator with electrical means of raising and lowering the discharge pressure. When no DC current is fed to this device, it functions as a gas pressure regulator, supplying 3.5" w.c. pressure to the main operating valve.

Refer to the wiring diagram supplied with the furnace for proper wiring connections. Electronic modulation for heating controlled by a specially designed room thermostat (60°-85°F) is identified as Option AG7. Electronic modulation control systems for makeup air applications controlled by a duct sensor and temperature selector (55-90°F) are identified as either Option AG8 or Option AG9. The temperature selector setting for Option AG8 is on the amplifier; Option AG9 has a remote temperature selector. Both systems are available with an override thermostat.

25B. Computer Controlled Electronic Modulation between 50% and 100% Firing Rate (Option AG21)

With this option the furnace is equipped with a Maxitrol A200 signal conditioner which operates much the same way as the amplifier above to control the regulator valve. The conditioner accepts an input signal of either 4-20 milliamps or 0-10 volts from a customer-supplied control device such as a computer. With the dip switches on the condi-

25B. Computer Controlled Electronic Modulation (Option AG21) (cont'd)

tioner in the "on" positions, the conditioner accepts a 4-20 milliamp signal. In the "off" positions, the conditioner accepts a 0-10V signal. The conditioner converts the signal to the 0 to 20 volt DC current required to control the modulating valve. Temperature selection is through the computer software.

Figure 24 - A200 Control used on Options AG21 and AG40



25C. Electronic Modulation between 20% - 28% and 100% Firing Rate (U.S. Patent 6,109,255), Option AG39 - Model RPB only; not available on Size 350; available with natural gas only

Depending on the size, furnaces equipped with electronic modulation Option AG39 have a 20-28% turndown ratio. The furnace will ignite at any input rate in the available range and will maintain average thermal efficiencies equal to or greater than the thermal efficiency at full fire.

Model	Maximum Turndown %	MBH Input Range	Inlet Pressure to Modulating Valve (factory set)	Gas Supply Pressure Required
RPB 125	20	25-125	3.9" w.c.	5" w.c.
RPB 150	27	40.3-150	3.7" w.c.	5" w.c.
RPB 175	23	40.3-175	3.7" w.c.	5" w.c.
RPB 200	26	51.8-200	3.9" w.c.	5" w.c.
RPB 225	23	51.8-225	3.9" w.c.	5" w.c.
RPB 250	28	69-250	4.0" w.c.	5" w.c.
RPB 300	23	69-300	4.0" w.c.	5" w.c.
RPB 400	25	100-400	4.4" w.c.	6" w.c.

Furnaces with Option AG39 have stainless steel burners, a stainless steel heat exchanger, and a stainless steel bottom pan. The gas train includes a single-stage gas valve, a modulating valve, and two gas pressure switches. The burner rack is equipped with one flash carryover and a regulated gas lighter tube system. The carryover lighter tube receives its gas supply through the regulator, simultaneously with the gas to the burner. Control of the system is through a Maxitrol #A1092 amplifier with a corresponding remote temperature dial (Maxitrol #TD92).

Description of Operation of Option AG39

The gas supply (see pressure requirements in the table above) connects to the single-stage gas valve. To compensate for additional pressure loss through the modulating valve, the single-stage gas valve has a custom outlet pressure setting higher than when it is used on a standard gas manifold. The pilot tubing connects to the pilot port on the single-stage

gas valve. When the valve receives a call for heat from the amplifier and pilot is established, gas flow from the single-stage valve goes to both the modulating valve and the regulated lighter tube system. **When the signal from the amplifier to the modulating valve, requires less-than-high fire operation**, the modulating valve functions to lessen the gas flow to the burner to reduce the input rate to that required to maintain the desired temperature. When the input rate is reduced enough to decrease the gas pressure to 1.1" w.c., the primary gas pressure switch in the manifold activates the solenoid that controls the bypass damper in the venter/combustion air system. The bypass damper opens diverting some of the incoming air directly into the flue duct, reducing airflow through the burner. Safety switches monitor the position of the bypass damper. When the gas pressure increases above 1.1" w.c., the bypass damper closes. See the manifold arrangement in Figure 25.

Combustion Air Pressure Switch Setting

This uniquely designed modulation system requires combustion air pressure settings different from the standard system. The approximate settings for the combustion air proving switch at sea-level operation are:

Model RPB with AG39, AG40	Startup Cold	Equilibrium at Full Rate	Factory Setting
125,150,175,200,225	-1.3"w.c.±0.2	-1.05"w.c.±0.1	-1.0"w.c.±0.2
250,300,400	-1.2"w.c.±0.2	-0.95"w.c.±0.1	-.75"w.c.±0.5

Sensor Location

For the convenience of the installer, the duct temperature sensor is factory installed in the cabinet leg (See Figure 23). Although the sensor has a mixing tube, at this distance from the discharge it does not receive a true mix, so the temperature read by the sensor will be slightly higher than the actual air entering the ductwork. The system will provide comfort level heat if the selector is set slightly lower to compensate for this reading. The offset temperature will vary with the application. If a direct correlation of these two temperatures is required, move the duct sensor to a location in the ductwork about 10-12 feet from the furnace discharge.

Wiring and Service

For wiring, consult the wiring diagram attached to the furnace. All wires in the electrical box connecting the modulation controls must be rated for 150°C.

This is a unique system which includes custom-built components and custom settings. If service is required, follow the general troubleshooting guide on page 40 and the special troubleshooting guide.

25D. Computer Controlled Electronic Modulation between 20-28% and 100% Firing Rate (U.S. Patent 6,109,255), Option AG40- Model RPB only; not available on Size 350; available with natural gas only

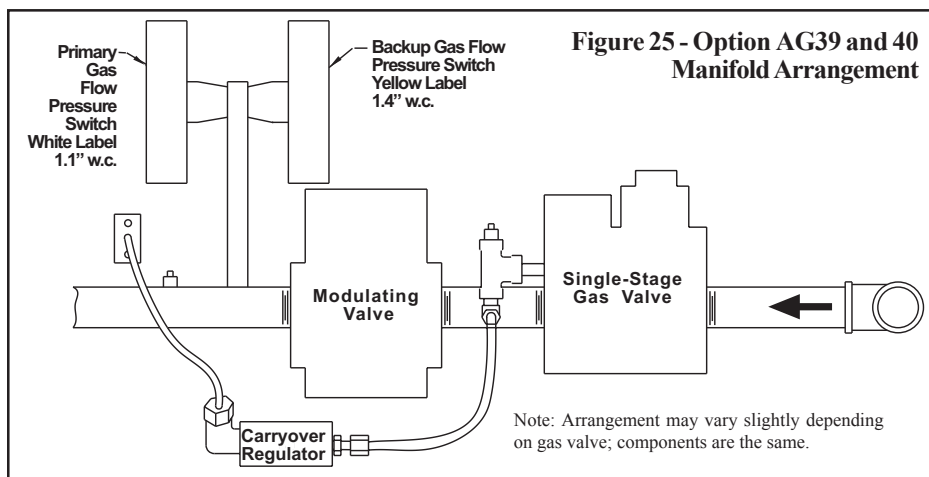

With this option the furnace is equipped with a Maxitrol A200 signal conditioner (see illustration in Paragraph 25B) which accepts an input signal of either 4-20 milliamps or 0-10 volts from a customer-supplied control device such as a computer. With the dip switches on the conditioner in the "on" positions, the conditioner accepts a 4-20 milliamp signal. In the "off" positions, the conditioner accepts a 0-10V signal. The conditioner converts the signal to the 0 to 20 volt DC current required to control the modulating valve. The heater functions and is equipped in the same way as described in Paragraph 25C (Option AG39) except that with computer control the temperatures are selected through the software and there is no temperature selector or duct sensor.

Troubleshooting Guide for Checking Bypass Combustion Air Damper Safety Circuit on Model RPB with Option AG39 or AG40

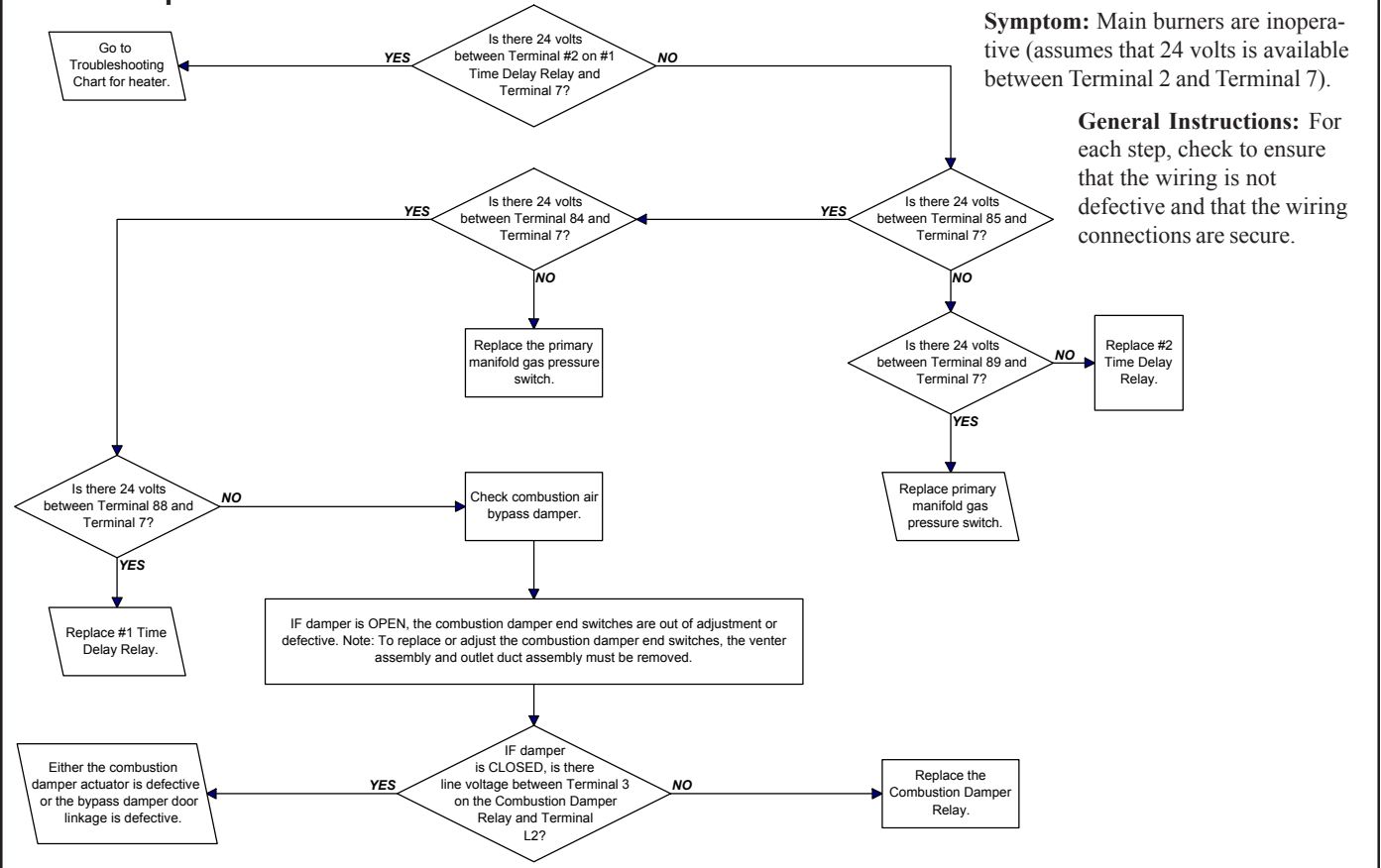

26. Direct Digital Control System

The heater is equipped with a specially programmed Johnson Controls Metasys® direct digital control unit. The unit is mounted in the blower cabinet; see Figure 26. If interfacing with the building's Johnson Controls Building Automaton System, follow the instructions included in the owner's envelope. The control unit has two analog outputs, six analog inputs, six binary outputs, and four binary inputs.

(NOTE: With the addition of a field-supplied integrator, the controller can also be used with a Honeywell or Siebe building management system or with any Lonworks™ or BacNet™ based protocol system.)

The unit can also operate the system as a stand alone control at the default settings.

Depending on which option was ordered, the following functions are available for monitoring and control through the building's environ-

Figure 26 - Johnson Controls Metasys® Unit is located in the blower cabinet

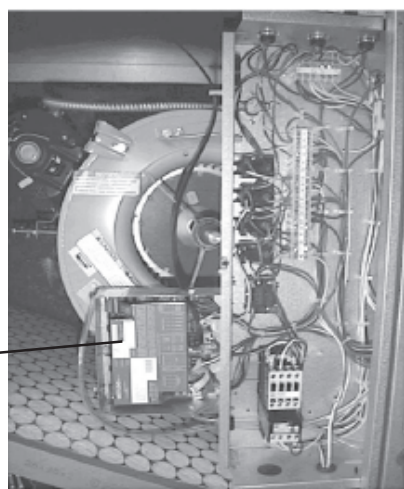

Johnson Controls Metasys® Unit

mental system. Option D1 has modulating dampers and modulating gas control; Option D2 has on/off dampers and modulating gas control; Option D3 has modulating dampers and two-stage gas control; Option D4 has on/off dampers and two-stage gas control. All of the systems with optional direct digital control systems include a firestat, freeze-stat, and an air proving switch. Temperature sensors are shipped separately and must be field-installed to monitor space temperature, discharge temperature and the temperature of the outside air entering the system.

27. Pilot and Ignition Systems

The horizontal pilot is located in the control end of the burner rack and is accessible after the control compartment panel has been removed. All pilots are target type with lint-free feature. Pilot gas pressure should be the same as supply line pressure. (See Paragraph 11.) If required, adjust the pilot flame length to approximately 1-1/4" with pilot adjustment screw in control valve body.

Indoor models have a standard match-lit thermocouple safety pilot or as an option, an intermittent spark ignition pilot system with or without lockout. Outdoor models have a standard spark ignition pilot system; lockout is optional. Refer to the wiring diagram supplied with the furnace for pilot system identification -- match-lit pilot is designated as AH1; spark pilot without lockout is AH2; and spark pilot with lockout is AH3.

Figure 27A - Burner Rack with Standard Match-Lit Pilot (indoor models only)

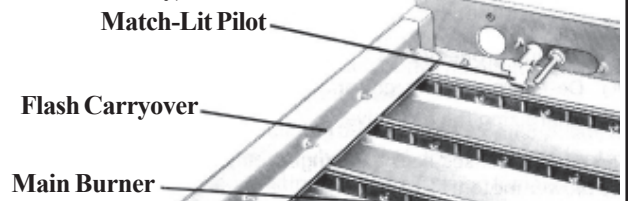

27. Pilot & Ignition Systems (cont'd)

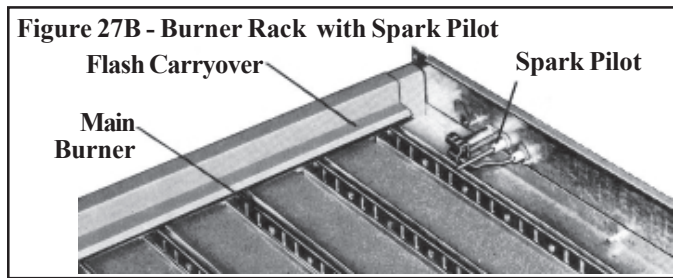

Intermittent Spark Ignition Safety Pilot Systems - There are two types of intermittent spark pilots -- one type shuts off the pilot gas flow between the cycles and the other not only shuts off the pilot gas flow between cycles but also has a lockout device that stops the gas flow to the pilot if the pilot fails to light in 120 seconds. This lockout feature requires manual reset by interruption of the thermostat circuit. Propane units require the spark ignition system with the lockout device. Refer to the wiring diagram supplied with the heater for pilot system identification and proper wiring.

NOTE: Outdoor units in Canada using propane, require lockout. Indoor units in U.S. and Canada, using propane require lockout.

Ignition Controller - As part of the intermittent safety pilot systems, the ignition controller provides the high voltage spark to ignite the pilot gas and also acts as the flame safety device. After ignition of the pilot gas, the ignition controller electronically senses the pilot flame. A low voltage DC electrical signal is imposed on the separate metal probe in the pilot assembly. The metal probe is electrically insulated from ground. The pilot flame acts as a conduction path to ground completing the DC circuit and proving pilot flame. With pilot flame proven, the ignition controller energizes the main gas valve.

If no spark occurs, check the following:

- Voltage between blue and white terminals (non-lockout type pilot) and Terminals 2 and 5 (lockout type pilot) on the ignition controller should be at least 20 volts and no higher than 32 volts. Refer to Troubleshooting (Paragraph 38) if no voltage is observed.
- Short to ground in the high tension lead and/or ceramic insulator.
- Pilot spark gap should be approximately $7/64$ ".

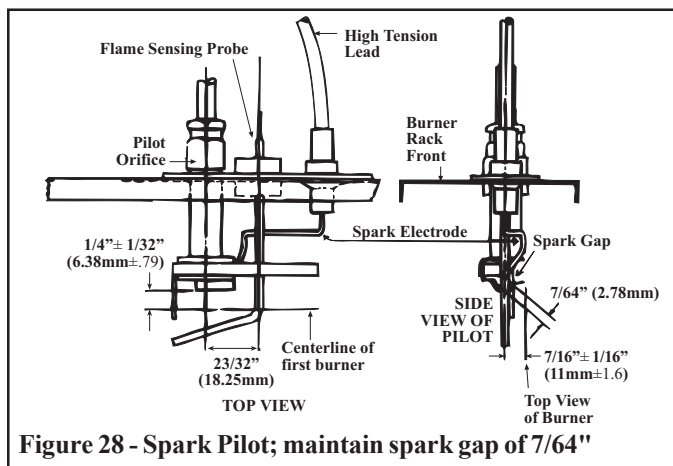

Figure 28 - Spark Pilot; maintain spark gap of $7/64$ "

NOTE: When checking for spark with the pilot burner assembly removed from the burner rack, the pilot assembly must be grounded to the heater for proper spark.

CAUTION: Due to high voltage on pilot spark wire and pilot electrode, do not touch when energized. See Hazard Levels, page 2.

If the above conditions are normal and no spark occurs, replace the ignition controller.

If the main gas valve fails to open with a normal full size pilot flame established, check for the following:

- Voltage between black and brown leads on the main gas valve is 20 to 32 VAC and there is no main gas flow with the built-in manual valve in FULL OPEN position -- the main valve is defective.
- No voltage between black and brown leads on the main gas valve -- check for disconnected or shorted flame sensor lead or flame sensor probe.

When the above conditions are normal and the main gas flow is still off, the ignition controller is probably defective. Do not attempt to service the ignition controller; it does not contain any replaceable components.

28. Burners and Carryover System

These duct furnaces have individually formed steel burners with accurately die-formed ports to give controlled flame stability without lifting or flashback with either natural or propane gas. The burners are lightweight and factory mounted in an assembly which permits them to be removed as a unit for inspection or service. The type of burner carryover system varies with both the type of gas and the model of furnace.

INDOOR Gravity-Vented Furnace - Natural gas burners are equipped with two flash carryover systems that receive a supply of gas simultaneously with the main burner. (NOTE: A natural gas burner rack on indoor furnaces manufactured prior to 3/95 has a gas lighter tube carryover and one flash carryover.) **Propane gas** burners are equipped with one flash carryover and a regulated gas lighter tube system.

OUTDOOR Gravity-Vented Furnace - Natural gas burners are equipped with a gas lighter tube carryover on the orifice end of the burner rack and a flash carryover on the other end. **Propane gas** burners are equipped with one flash carryover and a regulated gas lighter tube system.

OUTDOOR Power-Vented Furnace - Natural gas burners are equipped with a gas lighter tube carryover on the orifice end of the burner rack and a flash carryover on the other end. **Propane gas** burners are equipped with one flash carryover and a regulated gas lighter tube system.

During regular service, check the main burner ports, the carryover assemblies, and the orifices for cleanliness.

29. Burner Air Adjustment

Burner air shutters are not normally required on natural gas furnaces. Air shutters are required on propane gas units and may require adjustment. Before making any adjustments to the air shutters, allow the furnace to operate for about fifteen minutes with the air shutters open. The slotted screw on the end manifold bracket moves the air shutters and adjusts all burners simultaneously. Turning the screw clockwise opens the shutters; counterclockwise closes the shutters. After the furnace has been in operation for 15 minutes, close the air shutters observing the flame for yellow-tipping. Open the shutters until the yellow disappears. A limited amount of yellow-tipping is permissible for liquefied petroleum gases. Natural gas should not display any yellow-tipping.

When making the adjustment, close the air shutters no more than is necessary to eliminate the problem condition.

DANGER: Failure to install and/or adjust air shutters according to directions could cause property damage, personal injury, and or death.

30. Check Installation and Start-Up

Check the installation prior to start-up:

- ❑ Be certain the electrical supply matches voltage rating of the furnace. (Refer to the rating plate.)
- ❑ Check all field wiring against the wiring diagram. Be sure that wire gauges are as required for the electrical load.
- ❑ Be certain that the electrical entrances are sealed against the weather.
- ❑ Check that fuses or circuit breakers are in place and sized correctly.
- ❑ Be sure that all condensate drains are open. See Paragraph 9.
- ❑ Be certain that all optional manual reset controls (firestat and high gas pressure switch) are reset.
- ❑ Check clearances from combustibles. Requirements are shown in Paragraph 5.
- ❑ Check piping for leaks and proper gas line pressure. Bleed gas lines of trapped air. See Paragraph 11.
 - a) Turn manual shutoff valve to off position.
 - b) Turn gas supply on.
 - c) Observe gas meter for movement, or
 - d) Attach pressure gauge readable to .1" w.c. and after turning gas on for ten seconds, turn gas supply off. No change in pressure should occur over a three-minute period.
 - e) If either c) or d) above indicate a leak, locate leak by brushing a soapy solution on all fittings. Bubbles will appear at a leak. Repair and repeat tests.
- ❑ Power Vented Models - Check to make sure that flue discharge and combustion air inlet openings are free from obstructions.
- ❑ Gravity Vented Models - Be sure that vent cap is installed properly. If required, vent cap extension must be installed. See Paragraph 8B.
- ❑ Check blower pulley and motor pulley to be sure they are secure to the shafts. Check belt tension and alignment. See Paragraph 13.
- ❑ If the furnace is equipped with outside air and return air dampers, adjust the damper linkage. See Paragraph 34.

Start-Up

- ❑ Turn electric and gas supply on to the furnace. Adjust the thermostat or ductstat so that a call for heat exists. Observe for complete sequencing of safety pilot and ignition.

Operating Sequence with Match-Lit Pilot:

1. Set thermostat at lowest setting.
2. Follow lighting instructions and establish pilot.
3. Set thermostat at desired setting.
 - a) Firing rate is controlled by the single stage thermostat.
 - b) Thermostat fires burner at full rate on a call for heat.
 - c) Fan control senses heat exchanger temperature, energizing the blower motor.
4. Set thermostat at lowest setting for shutdown. Fan control keeps the blower motor on while the unit is hot.
5. Set summer/winter switch at "on" position (closed). Blower motor operates continuously.

Operating Sequence for Intermittent Spark Pilot System with or without 100% Lockout -- Gravity-Vented Models

1. Set the thermostat switch at its lowest setting.
2. Turn on power, main and pilot manual gas valves.
3. Set thermostat at desired setting.
4. On call for heat by the thermostat, the pilot gas valve and spark gap are energized to produce a pilot flame on each operating cycle. The sensing probe proves the presence of the pilot flame and energizes the safety switch portion of the control. The switch action de-energizes the spark gap and energizes the main valve. The main gas ignites and the unit fires at full rate. NOTE: If the flame is extinguished during main burner operation, the safety switch closes the main valve and recycles the spark gap. On unit equipped with a G770NGC-4 controller which includes lockout control, if the pilot is not established within 120 seconds (approximately), the unit locks out and must be reset by interrupting the power to the control circuit (See Lighting Instructions).
5. Fan control senses heat exchanger temperature, energizing the blower motor.
6. Set the thermostat switch at lowest setting for shutdown. Fan control keeps the blower motor on while unit is hot.
7. Set summer/winter switch at "on" position (closed). Blower motor operates continuously.

Operating Sequence -- Power-Vented Models

1. Set the thermostat switch at its lowest setting.
2. Turn on power, main and manual gas valves.
 - (a) Firing rate is controlled by the thermostat.
 - (b) Blower motor operates from heat exchanger temperature.
3. Set thermostat switch at desired setting.
4. Thermostat calls for heat
 - (a) The venter motor is energized after 15-second (approximate) time delay.
 - (b) Venter flow switches from N.C. to N. O. contacts, energizing the pilot gas valve and spark gap to produce a pilot flame on each operating cycle. The sensing probe proves the presence of the pilot flame and energizes the safety switch portion of the control. The switch action de-energizes the spark gap and energizes the main valve. The main gas ignites and the unit fires at full rate.
5. If the flame is extinguished during main burner operation, the safety switch closes the main valve and recycles the spark gap. On unit equipped with a G770NGC-4 controller which includes lockout control, if the pilot is not established within 120 seconds (approximately), the unit locks out and must be reset by interrupting the power to the control circuit (See Lighting Instructions).

Check installation after start-up

- ❑ With the unit in operation, measure manifold gas pressure. High fire manifold pressure for natural gas should be 3.5" w.c. and 10" w.c. for propane gas. See Paragraph 11.
- ❑ Turn the unit off and on, pausing two minutes between each cycle. Observe for smooth ignition. On two-stage or modulating burner systems, manipulate temperature adjustment slowly up and down to see if control is sequencing or modulating properly. Raising temperature setting drives burner on or to full fire.
- ❑ Observe burner flame at full fire. Natural gas flame should be about 1-1/2" in height with blue coloring. Propane gas flame should be approximately the same length with blue coloring. Yellow tipping may appear on propane gas. If yellow extends beyond 1/2 to 3/4", adjust air shutters. See Paragraph 29.

30. Check Installation and Start-Up (cont'd)

Check installation after start-up (cont'd)

- ❑ Close all panels tightly. With the heater on, check limit control by completely blocking off distribution air. The limit control should open within a few minutes, shutting off the gas supply to the main burners.
- ❑ If the system is equipped with an optional dirty filter switch, set the switch. Follow the instructions in Paragraph 35C.
- ❑ Place "Owner's Envelope" containing Limited Warranty Card, this booklet, and any optional information in an accessible location near the heater. Follow the instructions on the envelope.

DANGER: The gas burner in this gas-fired equipment is designed and equipped to provide safe and economically controlled complete combustion. However, if the installation does not permit the burner to receive the proper supply of combustion air, complete combustion may not occur. The result is incomplete combustion which produces carbon monoxide, a poisonous gas that can cause death. Safe operation of indirect-fired gas burning equipment requires a properly operating vent system which vents all flue products to the outside atmosphere. FAILURE TO PROVIDE PROPER VENTING WILL RESULT IN A HEALTH HAZARD WHICH COULD CAUSE SERIOUS PERSONAL INJURY OR DEATH.

Always comply with the combustion air requirements in the installation codes and instructions. Combustion air at the burner should be regulated only by manufacturer-provided equipment. NEVER RESTRICT OR OTHERWISE ALTER THE SUPPLY OF COMBUSTION AIR TO ANY HEATER. Indoor units installed in a confined space must be supplied with air for combustion as required by Code and in Paragraph 6A of this heater installation manual. MAINTAIN THE VENT SYSTEM IN STRUCTURALLY SOUND AND PROPERLY OPERATING CONDITION.

OPTIONAL ACCESSORIES

31. 100% Outside Air Hood (outdoor models)

Outside air hood (Option AS2) is a weatherized, screened hood designed to be field assembled and installed around the horizontal inlet air opening of the blower cabinet. The air hood includes factory-assembled louvers (U.S. Patent 4,999,037) designed to help eliminate moisture from the inlet air. Complete installation instructions are packaged with the air hood option.

CAUTION: It is recommended that the inlet to the outside air hood NOT be facing into the prevailing wind. Allow 14" minimum clearance from the bottom of the air hood to the mounting surface.

Installation Instructions - 100% Outside Air Hood

Refer to Figure 30. All screw ends except those across the bottom should be inside the air hood.

To avoid possible damage, it is recommended that the outside air hood be installed after the system has been placed on the roof. The air hood should be installed before the heater is operated. Do not install the hood while the system (furnace or blower) is in operation.

1. **Top Panel** -- On the air inlet side of the blower cabinet, remove the factory-installed screws attaching the blower cabinet top. Slide the air hood top panel underneath the edge of the blower cabinet top. **The edge of the air hood top panel must be between the blower cabinet top and the end panel.** Reinsert all of the sheetmetal screws.
2. **Side Panels** -- Slide the air hood right side panel into the groove in the blower cabinet end panel. Be sure that the side panel is underneath and to the inside of the air hood top panel. Attach to the blower cabinet and the air hood top using the required number of sheetmetal screws. Repeat with the left side panel.

Form RZ 403, Mfg No. 131782, Page 30

Figure 29 - Dimensions of Optional Outside Air Hood

The width of the outside air hood is the same as the width of the blower cabinet.

Size	Width of Outside Air Hood	
	inches	mm
75,100,125	53-3/8	1356
150,175	34-1/8	867
200,225	39-5/8	1006
250,300	47-7/8	1216
350	53-3/8	1356
400	58-7/8	1495

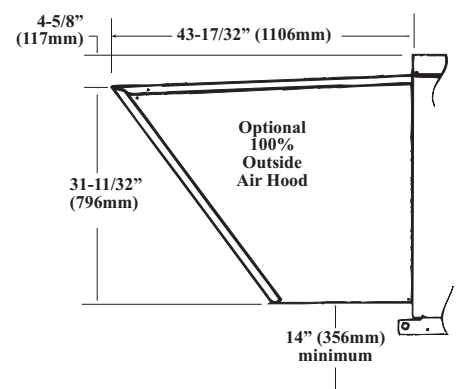

3. **Bottom Panel** -- Position the air hood bottom panel so that it is to the **inside** of the two side panels and **above** the factory-installed support angle. Attach to the side panels.
If the bottom panel does not rest tightly against the support angle, follow these instructions to adjust the position of the support angle:
 - a) Slightly loosen (do not remove the screws).
 - b) Slide the support angle up so that it is against the bottom panel.
 - c) Tighten the screws.Attach the support angle to the air hood bottom panel. The bottom panel of the air hood and the support angle should be tight together; do not draw with the sheetmetal screws.
4. **Louver Assembly** -- With the intake screen toward the inside of the hood position the pre-assembled vertical louver assembly in the inlet opening of the air hood.

Using the remaining sheetmetal screws, attach the louver assembly to the air hood side panels at the holes.

Figure 30 - Assembly Drawing of Option AS2 Outside Air Hood

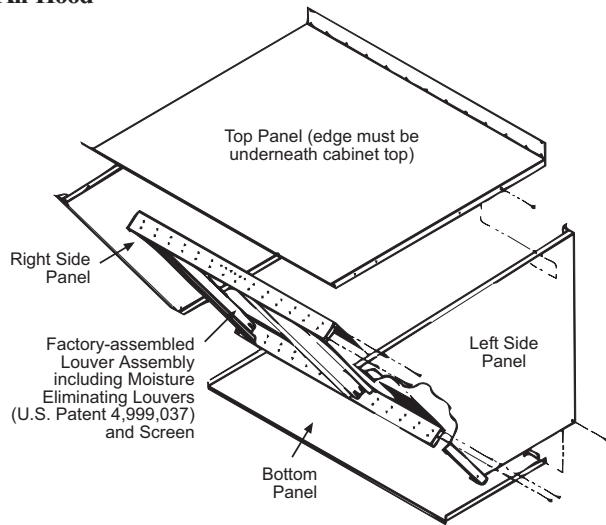

Size	Top Panel	Bottom Panel	Louver Assy
75,100,125	100227	100234	103773
150,175	100228	100235	103774
200,225	100229	100236	103775
250,300	100230	100237	103776
350	100231	100238	103777
400	100232	100239	103778

NOTE: Either a manufacturer designed optional air inlet hood as shown in Paragraph 31 or an evaporative cooling module as shown in Paragraph 33 is required to ensure complete weather resistance.

32. Screened Air Hood for 30% Outside Air Opening, Part of Inlet Air Options AR6 and AR7 (Outdoor models)

The outside air hood included in the air inlet options that have a 30% outside air opening (Option AR6 or AR7) is shipped separately for field installation. Instructions for attaching are packaged with the air hood.

Installation Instructions - 30% Outside Air Hood

1. On the inlet air side of the blower cabinet, remove the factory installed screws attaching the blower cabinet top.
2. Slide the air hood top flange underneath the lip of the blower cabinet top and the sides into the vertical slots. **The air hood flange must be between the blower cabinet top and the cabinet end panel.**
3. Reinsert all of the sheetmetal screws.

Figure 31 - Installation of Air Hood on Cabinets with 30% Outside Air Opening Options

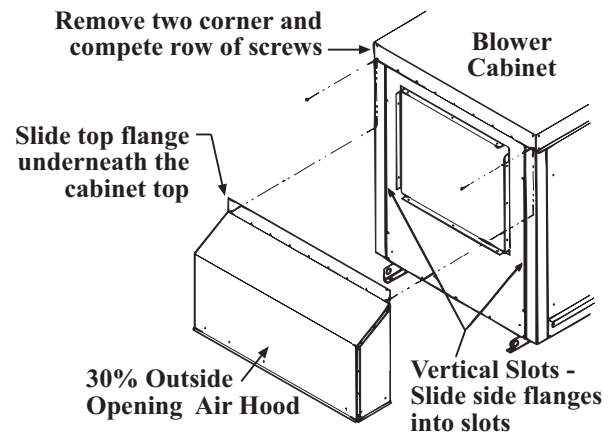

33. Optional Evaporative Cooling Module (outdoor models)

Evaporative cooling provides excellent comfort cooling at low initial equipment and installation costs and low operating and maintenance costs. Direct evaporative cooling works solely on the principle that water in direct contact with a moving airstream will eventually evaporate if the droplets have long enough exposure. This evaporative cooling module uses wetted rigid cellulose or rigid glass fiber media to retain water in order to allow time for evaporation.

CAUTION: Water reservoir must be drained and pump motor turned off when outside temperature falls below 32°F(0°C). Pump must never be operated without water in the reservoir. See Hazard Levels, page 2.

Figure 32 - Optional Evaporative Cooling Module is factory-installed on the blower cabinet



The optional evaporative cooling module is equipped with high efficiency pad media of either 6" or 12" rigid cellulose (Option AS3 or AS4) or 6" or 12" rigid glass fiber (Option AS5 or AS8). Six-inch media provides 68% efficiency; 12" media provides 90% efficiency. Efficiency values are stated at maximum allowable CFM without the addition of a moisture elimination pad with an inlet dry bulb temperature of 95°F and inlet wet bulb temperature of 65°F. The evaporative cooling

efficiency is a function of inlet temperature and of face velocity through the media. The stated cooling efficiency will rise with the decrease of CFM and the increase of inlet temperature. Moisture elimination pads (Option ASA1) may be used on all units but are required on high CFM units as listed below.

Heater Size	Moisture Elimination Pad Required on Evaporative Cooling Module
75	2601 - 2645 CFM
100	2601 - 3400 CFM
125	2601 - 3800 CFM
150	3201 - 4700 CFM
175	3201 - 5000 CFM
200	3701 - 5100 CFM
225	3701 - 5150 CFM
250	4501 - 5800 CFM
300	4501 - 6300 CFM
350	5101 - 6800 CFM
400	5601 - 7100 CFM

33. Optional Evaporative Cooling Module (outdoor models) (cont'd)

The standard water controls for the evaporative cooling module include the float valve, the float switch, and pump assembly illustrated in the following paragraphs. If the cooling module has an optional AquaSaver® metering water system, it will not have these controls but will have a solenoid valve with a timer assembly for controlling water flow.

Installation Instructions - Evaporative Cooling Module

The evaporative cooling module is completely factory assembled, installed and wired. No additional roof mounting is necessary. Follow these instructions to field connect the water supply and make necessary checks and adjustments before operating the cooling module.

Supply and Drain Water Connections

Float Valve (Figure 33) - In a module with pump and float controls, a float valve maintains the appropriate water level in the reservoir.

Use a field-supplied 1/4" diameter tubing with a compression nut and tubing ferrule to connect the fresh water supply to the inlet of the float valve. See Figure 33. Place nut and ferrule over tubing and insert tubing into the float valve stem. Tighten nut securely.

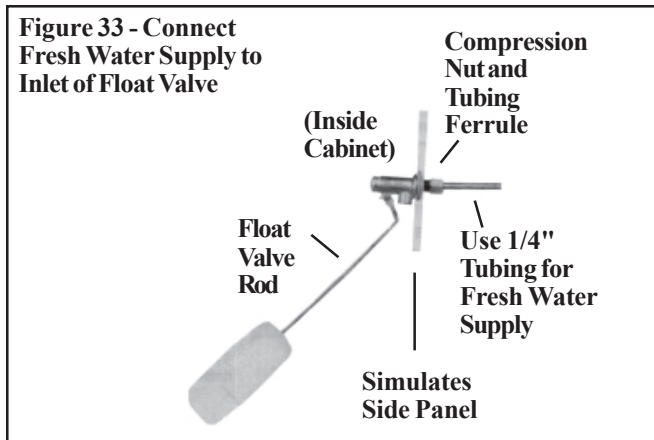

AquaSaver® Timed Metering Control System - If the cooling module is equipped with an optional timed metering system, connect a 1/2" water line to the fitting on the side of the cooling module.

Due to various water pressures and installation conditions, the water supply line may bang abruptly when the solenoid valve in the AquaSaver system closes. This banging can be minimized by installing an optional water hammer arrestor in the supply line. When installing an optional water hammer arrestor, select an indoor (above 32°F) location, either horizontal or vertical, in line with and as close to the solenoid valve as possible. Follow the manufacturer's instructions to install and maintain the water hammer arrestor.

All Cooling Modules - A manual water shutoff valve should be installed upstream of the cooling module inlet, at a convenient non-freezing location, to allow the water supply to be turned on and off. If necessary, install a bleed line between the manual valve and the cooling module to allow drainage of the line between the shutoff valve and the cooling module.

All cooling modules are equipped with an overflow and drain fitting. The fittings are in the cabinet bottom and come complete with a lock nut and a sealing gasket. Check these fittings for tightness before installing the overflow and drain piping. The drain and overflow fitting will accommodate a 3/4" garden hose thread and is tapped with a 1/2" female pipe thread for iron pipe.

An optional automatic fill and drain kit (Option CT) is available that will automatically release supply water to the cooling module when a call for cooling is made and drain all water from the reservoir when the cooling switch is deactivated or a cooling thermostat is satisfied. See Figure 34. If installing an optional fill and drain kit, follow the instructions with Figure 34. Consult wiring diagram for electrical connections.

Bleed Line Connection (Does not apply to module with optional timed metering system.) - Shipped in the evaporative cooling module bottom pan, find a 1/4" I.D. x 1/2" N.P.T. nylon bleed line fitting (hose barb). Thread the fitting into the female adapter located opposite the pump/inlet side of the water distribution line. The hose barb will protrude from the side of the cabinet (See Figure 35). Attach a 1/4" I.D. hose

Instructions for Installing Optional Fill & Drain Kit

NOTE: Follow instructions included in the valve packages for attaching valves to the water line only. The remainder of the installation instructions with the valves does not apply to this type of application.

Water Line Connections (See Figure 34):

Supply (3-Way Valve) Connections - Connect the water supply line to "B" (normally closed). Connect the water drain line to "A" (normally open). Connect the middle outlet to supply the water to the cooling module reservoir.

Drain (2-Way Valve) Connections - Connect the drain pipe from the reservoir to the valve inlet. Connect the outlet side into the drain lines from the cooling reservoir and the supply valve.

Electrical Connections (requires black and white 14-gauge wire) - Refer to Wiring Diagram provided with the furnace:

WARNING: Risk of electrical shock. Disconnect the power.

1. Refer to the wiring diagram for terminal connections. (NOTE: If kit is not ordered with the system, connections will not be shown on the diagram. Terminal connections are specific to each system. Contact the factory for terminal connections. Be prepared to provide all model information.)

Figure 34 - Water Connections including Optional Drain and Fill Kit

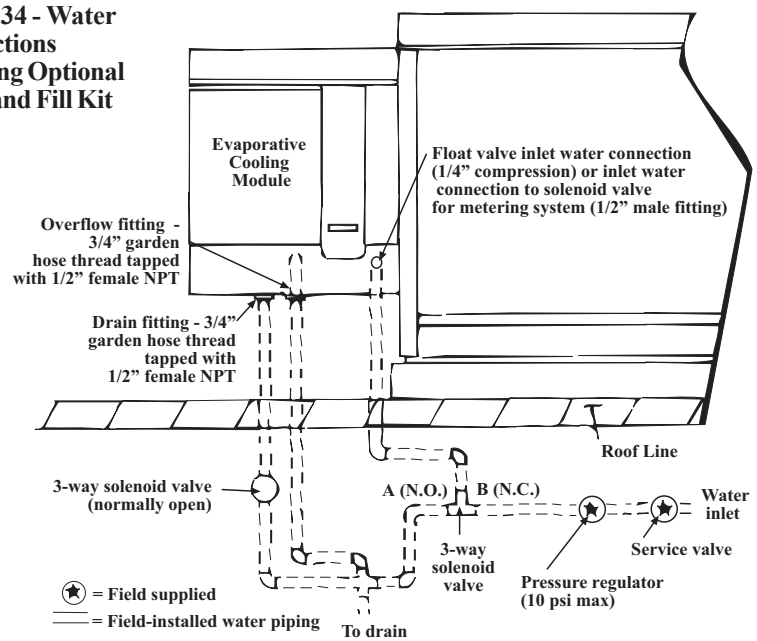

2. Run field-supplied black wire from the electrical compartment (terminal on the wiring diagram) of the evaporative cooling module and connect to the black wire on both the 3-way and the 2-way valve.
3. Run field-supplied white wire from the electrical compartment (terminal on the wiring diagram) of the evaporative cooling module and connect to the white wire on the 2-way valve.

Figure 35 - Bleed Line Connection

Install the hose barb and attach bleed line.



to the barb and run the hose to the nearest drain.

Discharging a quantity of water by "bleed off" will limit the concentration of undesirable minerals in the water being circulated through the cooling module. Minerals buildup because evaporation only releases "pure water vapor" causing the concentration of contaminants in the water to increase as the evaporation process continues to occur. The minerals accumulate on the media, in the water lines, on the pump, and in the reservoir.

Adequate bleed off is important to maintaining an efficiently operating evaporative cooling system.

Filling & Adjusting the Water Level in the Reservoir

Float and Pump Control System -- Turn on the water supply. Check for good flow.

When the float valve (Figure 33) shuts off the water supply, measure the water depth. The depth of the water should be approximately 3". It may be necessary to adjust the float valve to obtain the proper water level or to free the float valve from obstructions. To adjust the float valve, simply bend the rod upward to raise the water level or downward to decrease the water level.

Adjusting Water Flow Over Pads

Proper water flow over the evaporative cooling media is critical to extend the life and maintain the efficiency of the pads. Follow the instructions to adjust water flow.

CAUTION: Do not flood the media pads with extreme quantities of water for long periods as this will cause premature breakdown of the media. An even flow from top to bottom of the media with the least amount of water is all that is required to assure maximum efficiency and media life span. More water does not provide more evaporation or more cooling.

WARNING: Adjust ball valve only when the power is disconnected from the system. Failure to do so can cause electrical shock, personal injury or death.

Float and Pump Control System - Using the ball valve, located in the middle of the length of hose running from the pump to the distribution line inlet (Figure 36), adjust the valve handle to allow the flow to completely dampen the media pads from top to bottom.

Operate the unit watching the water flow. After 15 minutes with the blower in operation, the water should have completely dampened the pads but should not be flowing off the entering side of the media. If water is flowing off the entering side of the media, turn the system off, disconnect the power, and reduce the entering water flow.

AquaSaver® Timed Metering Control System -- NOTE: Water flow and pad wetting time should be adjusted at maximum air flow and wet bulb depression to assure complete wetting of the media at the extreme operating conditions.

In addition to adjusting water flow, the timing of the water on/off cycle can be adjusted. Adjustments are correct when **1)** the water rises from the holes in the sprinkler pipe (See Figure 37A) consistently along the entire

Figure 36 - Disconnect the power and use ball valve to adjust water flow



pipe length, **2)** the media pads wet evenly after a few "ON" cycles (no dry spots or dry streaks), and **3)** a slight amount of excess water collects at the drain at the completion of the "ON" cycle.

1) AquaSaver® Water Flow Adjustment - Using the ball valve illustrated in Figure 36, adjust the water flow depending on the pad height. See Figure 37A.

Figure 37A - Adjust Water Flow with the Ball Valve in Figure 36

Pad Height	A = Water rise from Sprinkler Pipe
24"	1/8" to 1/2"
48"	1/4" to 1/2"



2) AquaSaver® Timer Adjustment - At any given temperature, the media pads should completely wet from top to bottom during the ON cycle. If the ON time is less than 45 seconds or greater than 90 seconds at 80°F, adjust the timer. Remove the junction box cover to access the timer adjustment screw (See Figure 37B).

Figure 37B - Junction Box with AquaSaver® Controls



Timer Adjustment Screw

- To **increase** the ON time, turn the adjustment screw **clockwise**; one complete turn will increase ON cycle by 12 to 14 seconds.
- To **decrease** the ON time, turn the adjustment screw **counterclockwise**; one complete turn will decrease ON cycle by 12 to 14 seconds.

Through the use of a bimetallic strip, the timer is temperature sensitive and automatically increases the ON time approximately one second for each 1°F rise above the 80°F factory setting. The ON time will equal the setting for 80°F plus a second for each degree above 80.

Let the unit cycle a few times to verify that the water flow is correct and the soaker hose is operating properly to wet the media pads completely from top to bottom during the ON cycle.

All Modules -- Check the reservoir for any water leaks. The reservoir was water tested, but if any small leaks are present, drain the reservoir and apply a waterproof silicone sealer around corners and welds.

Evaporative Cooling Module Maintenance

Reference: Troubleshooting Guide for Evaporative Cooling Module is on page 43.

WARNING: Disconnect all power to the unit before doing any maintenance. Failure to do so can cause electrical shock, personal injury or death.

Media -- Over time, excessive amounts of mineral deposits may begin to build up on the media. Annually, scale and dirt should be washed off the entering surface of the media. Remove the pad retainers and screen (See Steps 1-3 and 6-8 of Media Replacement Instructions). Clean the media using a garden hose, mild, and a **soft** bristled brush. When the media becomes too clogged with mineral deposits and dirt that it cannot be cleaned, the pads should be replaced. The average pad life expectancy is approximately three cooling seasons.

33. Optional Evaporative Cooling Module (outdoor models) (cont'd)

Media Maintenance (cont'd)

Select the correct replacement part numbers and order replacement media pads from your distributor. Follow the instructions that follow and remove and replace pads as shown in Figures 38 and 39.

Furnace Size	Media Pad Sizes (inches)	Qty	Replacement Part No. (each)			
			Cellulose Fiber		Glass Fiber	
			6"	12"	6"	12"
75,100, 125	24 x 12	2	105985	106021	106037	106029
	24 x 2-3/8	1	105986	106022	106038	106030
150, 175	24 x 12	2	105985	106021	106037	106029
	24 x 7-7/8	1	105987	106023	106039	106031
200, 225	24 x 12	3	105985	106021	106037	106029
	24 x 1-3/8	1	105988	106024	106040	106032
250, 300	24 x 12	3	105985	106021	106037	106029
	24 x 9-5/8	1	105989	106025	106041	106033
350	24 x 12	4	105985	106021	106037	106029
	24 x 2-7/8	1	105990	106026	106042	106034
400	24 x 12	4	105985	106021	106037	106029
	24 x 8-5/8	1	105991	106027	106043	106035

Instructions for Replacing Evaporative Cooling Media

1. Remove the three sheetmetal screws that hold the top pad retainer. Release the top pad retainer from the cooling module.
2. Remove the three sheetmetal screws that hold the bottom pad retainer. Release the bottom pad retainer from the cooling module.
3. Disengage the inlet screen from media pads and remove.
4. Slide all media pads horizontally away from the cooling module until clear of bottom reservoir pan. Dispose of properly.
5. Slide media pads over both support rails until back stop is encountered. Media **must** be placed as shown in Figure 39.
6. Center screen on the incoming air side of the media.
7. Replace the bottom pad retainer by securing the retainer between the pad and the reservoir pan. Fasten with the three sheetmetal screws removed in Step 2.
8. Replace the top pad retainer by securing the retainer between the pad and top of the cooling module. Fasten with the three sheetmetal screws removed in Step 1.

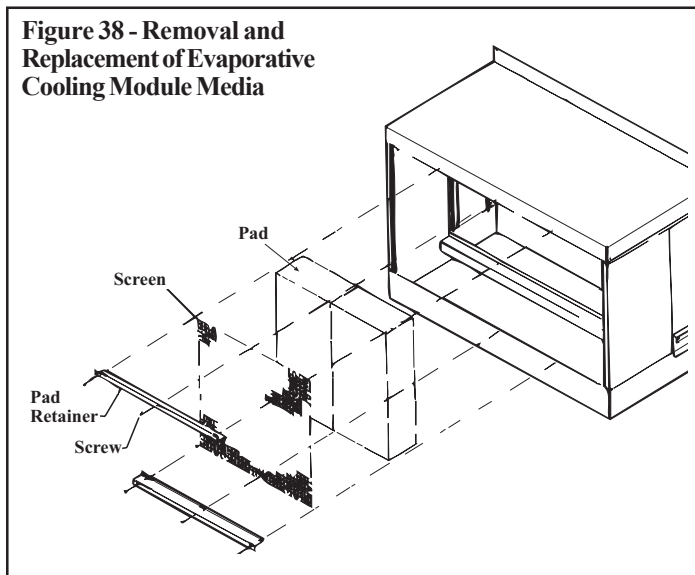

Figure 38 - Removal and Replacement of Evaporative Cooling Module Media

IMPORTANT: The media is made up of two different sheets of cooling material. Each sheet has its own unique angle. When replacing the cooling media, **BE CERTAIN** that the 45° angle slopes downward toward the incoming outside air. If the media is not installed properly, water blowoff from the media pads will occur.

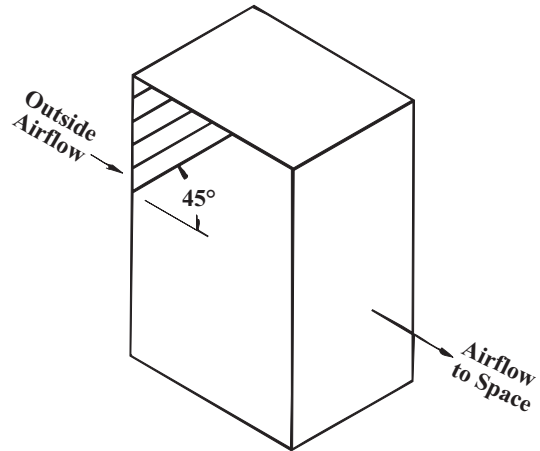

Figure 39 - Media must be installed with 45° angle sloping downward toward the incoming outside air.

Water Feed and Distribution Line -- Annually, the water supply line and the water distribution line (either PVC pipe or water sock) should be flushed of debris and contaminants.

1. Remove the media pads. (Follow media replacement instructions.)
2. Remove the water feed line from the downstream side of the ball valve and unscrew the water bleed line barbed hose fitting.
3. Force a fresh water supply through the water inlet hose and thoroughly flush the distribution line.
4. Reassemble being careful to install media with air flow direction as shown in Figure 39.

Water Pump and Inlet Basket Screen (Does not apply to module with optional timed metering system.) -- Annually, the pump and inlet basket screen should be removed, disassembled, and cleaned.

WARNING: Do not expose pump motor or any part of the electrical box to water. Evaporative cooling pump is NOT submersible.

1. Disconnect the power supply to the unit.
2. Remove the service panel and the junction box door. Disconnect the two-line voltage power supply wires from the terminal block inside the junction box.
3. Disconnect the water feed line hose from the upstream side of the ball valve.
4. Unscrew the four sheetmetal screws holding the junction box to the cooling module. Remove the junction box-pump-float switch assembly (See Figure 40).
5. Dislodge the inlet basket screen from the pump and clean any buildup of debris and dirt. Carefully remove the base cover plate from the bottom of the pump. Using a mild soap solution, wash all deposits from the inside of the pump and remove all debris from the impeller.
6. Reassemble the pump. Replace the parts in exact reverse order, being careful that everything is returned to its proper position.

Figure 40 - Remove Junction Box, Pump and Float Switch as an Assembly

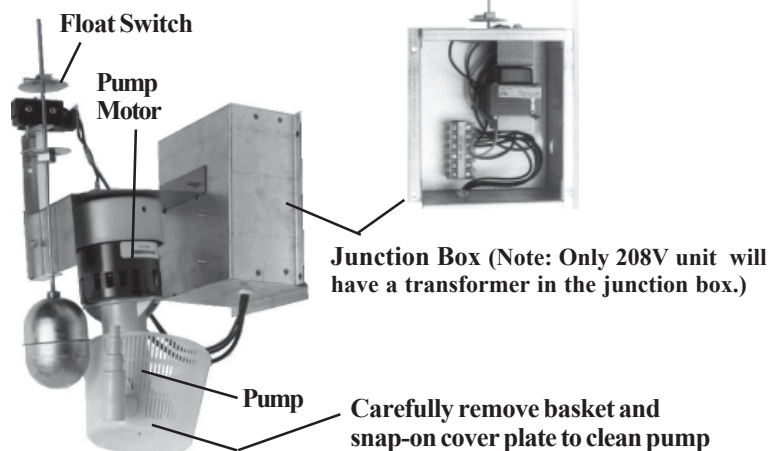

34. Optional Dampers and Controls (See Wiring Diagram supplied with unit.)

Figure 41A - Control Locations for Air Inlet/Damper Options on Indoor Model

- 1 Outside Air Damper
- 2 Return Air Damper
- 3 Damper Motor
- 4 Potentiometer
- 5 Mixed Air Controller
- 6 Outside Air Changeover
- 7 Warmup Control
- 8 Potentiometer

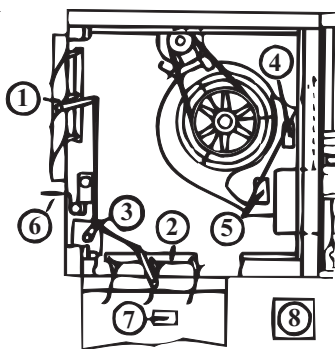

Figure 41B - Location of Controls for 30% Outside Air Hood and Damper Options (AR6 or 7) - Outdoor Models only

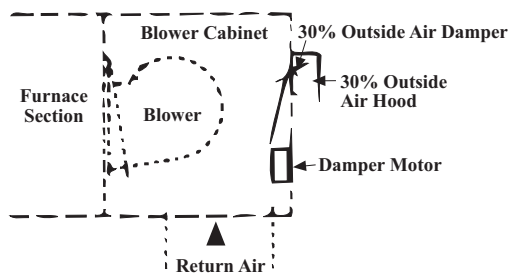

Figure 41C - Control Locations for 100% Outside Air and 100% Return Air Damper Options on Outdoor Models

- 1 Damper Motor
- 2 Return Air Damper
- 3 Potentiometer
- 4 Potentiometer
- 5 Mixed Air Controller
- 6 Warmup Control
- 7 Outside Air Damper
- 8 Damper Motor Transformer
- 9 DDC Interface Control

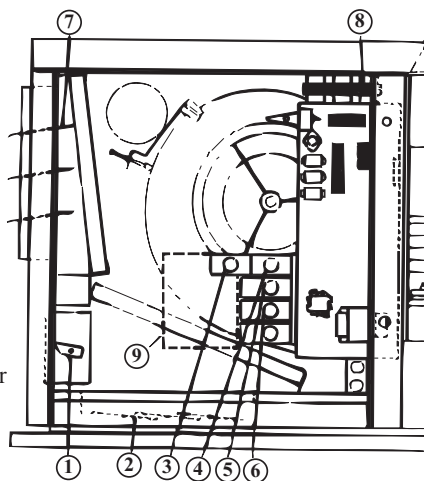
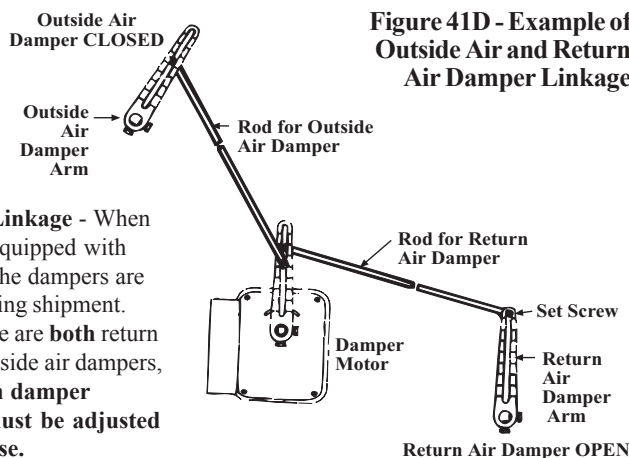

Figure 41D - Example of Outside Air and Return Air Damper Linkage



Damper Linkage - When units are equipped with dampers, the dampers are closed during shipment. When there are **both** return air and outside air dampers, **the return damper linkage must be adjusted prior to use.**

1. Loosen the set screw on the return air damper rod at the damper arm.
2. Manually open the return air dampers. While the dampers are opening, the damper rod and arm will automatically move to their correct positions.
3. Tighten the set screw.

NOTE: The illustrations in Figure 41A and 41C are intended to show location only of various air control accessories and do not represent suggested combinations of accessories.

Pressure Null Switch (Used to control Outside Air Dampers in Inlet Air Option AR23)

The pressure null switch used in Option AR23 is a Dwyer #1640-0 with a range of .01-.20" w.c. It is shipped separately for field installation. Refer to the following paragraphs and the manufacturer's installation instructions included with the switch.

Description and Application - The pressure null switch is a diaphragm operated differential pressure switch used in makeup air applications to control building pressure. It maintains a selected positive or negative pressure setpoint by changing the amount of outside air being introduced to the building through the modulating outside air dampers. As more pressure is required in the building, the pressure null switch activates the damper motor driving the outside air damper towards the full open position and the recirculated air damper towards the closed position. Conversely, as less pressure is required, the switch drives the dampers in the opposite direction.

34. Optional Dampers and Controls (cont'd)

Installation Instructions for Pressure Null Switch (See Figure 41D)

1. Select an indoor location free from excessive vibration where oil or water will not drip onto the switch and where ambient temperature will be within a range of -30°F (dry air) to 110°F.
2. **Mount the switch with the diaphragm in a vertical plane.** The switch is position sensitive and is calibrated to operate properly when the diaphragm is vertical. Mount switch securely.
3. Connect the pressure taps on the top of the switch to sources of air pressure differential. Metal tubing with 1/4" O.D. is recommended, but any tubing system which will not unduly restrict the air flow may be used. To maintain a positive building pressure, vent the low pressure tap to the outdoors and allow the high pressure tap to monitor building pressure. To maintain a negative building pressure, reverse the functions of the high and low pressure taps. In either case, be sure that the outdoor vent is protected from the wind and screened from insects.
4. **Adjustment of the Switch** - The "HIGH" actuation point of the null switch is indicated on a calibrated scale secured to the transparent range screw enclosure. Building pressure is set by turning the adjustment screw. The "Low" actuation point is set by adjusting the span of the null by turning the span adjustment screw. The span range is .01 to .03" w.c.

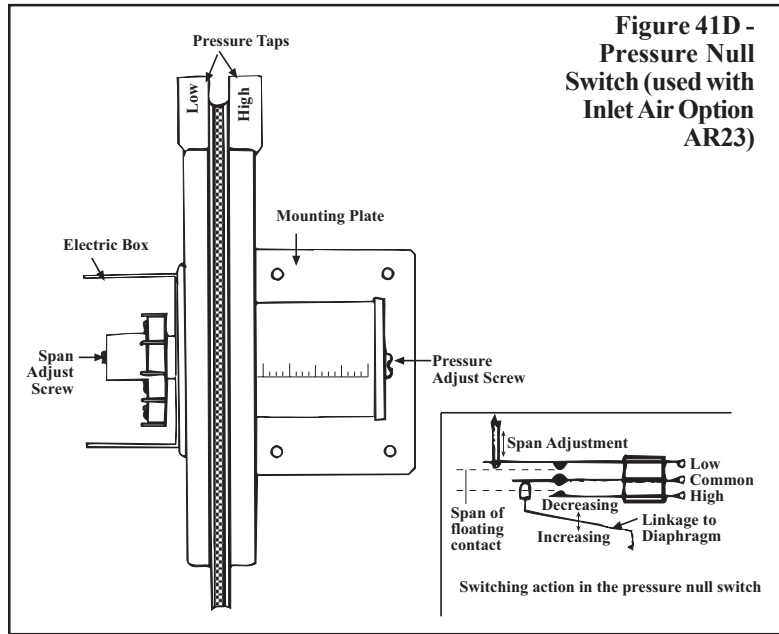

IMPORTANT: To eliminate shipping damage to the switch contacts, the manufacturer reduced the span adjustment to zero before shipping. The span should be adjusted prior to using the switch. (If the switch has been installed, disconnect the vent tube so that the null switch is in a neutral position.) Remove the electrical box cover and while observing the contacts, turn the span adjustment screw slowly in a clockwise direction. Continue turning the adjustment screw until you are able to see gaps between the common and both the low and high contacts. A minimum gap provides the greatest sensitivity. The wider the gap the lower the sensitivity.

5. See the wiring diagram included with the furnace to make electrical connections.

35. Optional Filter Rack and Filters

35A. Filter Rack and Filters - Indoor Models

Filter racks and filters are factory installed optional equipment on indoor systems. 1" or 2" disposable, pleated disposable, or permanent filters are available. For pressure drops, see the chart for outdoor models in Paragraph 35B.

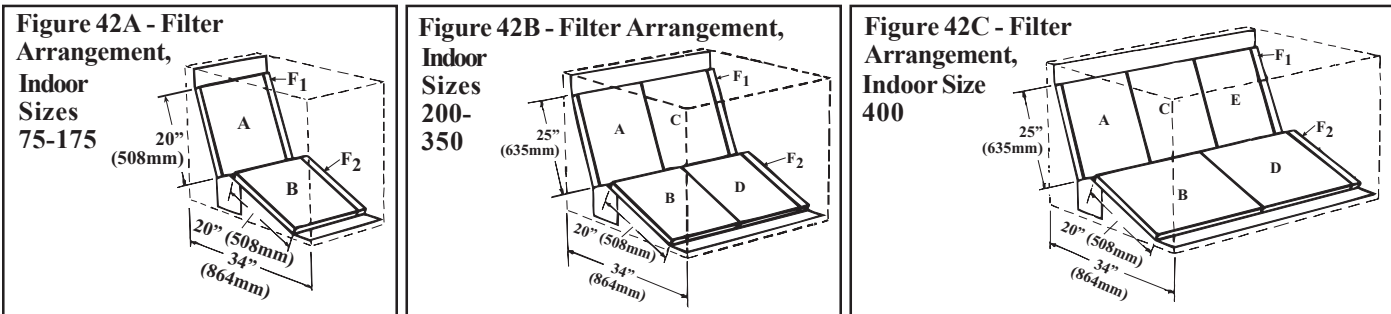

Filter and Filler Sizes for Indoor Models	Heater Size	Filters					Metal Fillers		Figure Reference for Qty of Filters & Fillers
		A	B	C	D	E	F1	F2	
	75, 100, 125	20x20	20x20	--	--	--	--	--	42A
	150, 175	20x25	20x25	--	--	--	13/16	13/16	
	200, 225	16x25	16x20	16x25	16x20	--	--	--	42B
	250, 300	20x25	20x20	20x25	20x20	--	--	--	
	350	20x25	20x25	20x25	20x20	--	4-13/16	--	
400	16x25	20x25	16x25	20x25	16x25	2-5/8	1-1/16	42C	

35B. Filter Rack and Filters - Outdoor Models

Filter rack and filters are factory installed optional equipment. Filters are available in 1" or 2" disposable, 1" or 2" permanent aluminum, and 1" or 2" pleated disposable. Tested in accordance with ASHRAE 52-76 Test Standard, the filters provided have the specifications shown in the table on the right. Size, quantity, and pressure drops of filters for outdoor models are in the table below. Refer to Figure 43, for filter arrangements.

Type of Filter		Average Efficiency	Average Arrestance
Disposable	1"	Less than 20%	75%
	2"	Less than 20%	80%
Permanent	1"	Less than 20%	53% to 60%
	2"	Less than 20%	64% to 67%
Pleated Disposable	1"	30% to 35%	90% to 93%
	2"	30% to 35%	90% to 93%

Filter Pressure Drops (" w.c.)

Heater Size	Qty & Size of Filters	CFM	Disposable		Permanent		Pleated		Heater Size	Qty & Size of Filters	CFM	Disposable		Permanent		Pleated			
			1"	2"	1"	2"	1"	2"				1"	2"	1"	2"	1"	2"		
75 100 125	(1) 20x25 (1) 25x25	575	0.00	0.00	0.01	0.01	0.02	0.01	250 300	(1) 20x20 (3) 20x25	1950	0.01	0.02	0.03	0.05	0.07	0.05		
		1000	0.00	0.01	0.02	0.03	0.05	0.04			2500	0.02	0.03	0.06	0.08	0.11	0.08		
		1500	0.01	0.02	0.04	0.06	0.12	0.08			3000	0.03	0.04	0.08	0.12	0.16	0.11		
		2000	0.01	0.02	0.08	0.11	0.22	0.15			3500	0.04	0.05	0.10	0.16	0.22	0.15		
		2500	0.02	0.03	0.12	0.17	0.34	0.23			4000	0.05	0.07	0.15	0.21	0.29	0.20		
		3000	N/A	N/A	0.17	0.24	0.49	0.33			4500	0.06	0.09	0.19	0.26	0.37	0.25		
		3500	N/A	N/A	0.24	0.34	0.67	0.45			5000	0.08	0.11	0.23	0.32	0.45	0.31		
		4000	N/A	N/A	0.31	0.43	N/A	N/A			5500	N/A	N/A	0.28	0.39	0.55	0.37		
150 175	(2) 16x20 (2) 16x25	1175	0.00	0.01	0.02	0.03	0.05	0.03			350	(2) 16x25 (3) 20x25	2750	0.02	0.03	0.06	0.08	0.12	0.08
		1500	0.01	0.01	0.04	0.06	0.07	0.05					3500	0.03	0.04	0.09	0.13	0.19	0.13
		2000	0.01	0.02	0.06	0.08	0.13	0.09					4000	0.04	0.06	0.12	0.17	0.25	0.17
		2500	0.02	0.03	0.10	0.14	0.20	0.14					4500	0.06	0.07	0.15	0.21	0.32	0.22
		3000	0.03	0.04	0.14	0.20	0.34	0.23					5000	0.07	0.09	0.19	0.26	0.40	0.27
		3500	0.04	0.05	0.20	0.28	0.40	0.27					5500	0.08	0.10	0.23	0.32	0.48	0.33
		4000	0.05	0.07	0.26	0.36	0.52	0.36					6000	0.08	0.12	0.27	0.38	0.57	0.39
		4500	N/A	N/A	0.32	0.45	0.66	0.45					6500	N/A	N/A	0.32	0.44	0.67	0.46
5000	N/A	N/A	0.36	0.54	0.82	0.56	7000	N/A	N/A	0.37			0.51	0.78	0.53				
200 225	(1) 16x20 (1) 16x25 (1) 20x20 (1) 20x25	1550	0.01	0.01	0.03	0.04	0.06	0.04	400	(1) 16x20 (1) 16x25 (2) 20x20 (2) 20x25			3100	0.04	0.04	0.06	0.08	0.12	0.08
		2000	0.01	0.01	0.05	0.07	0.10	0.07					3500	0.05	0.06	0.08	0.11	0.16	0.11
		2500	0.01	0.02	0.08	0.11	0.16	0.11					4000	0.06	0.07	0.10	0.14	0.21	0.14
		3000	0.02	0.03	0.11	0.16	0.23	0.16					4500	0.08	0.09	0.13	0.18	0.26	0.18
		3500	0.03	0.04	0.15	0.22	0.31	0.21					5000	0.10	0.12	0.16	0.22	0.32	0.22
		4000	0.04	0.05	0.20	0.28	0.40	0.27					5500	0.12	0.14	0.19	0.27	0.39	0.27
		4500	0.05	0.06	0.26	0.36	0.51	0.35					6000	0.14	0.17	0.23	0.32	0.46	0.32
		5000	N/A	N/A	0.32	0.44	0.63	0.43			6500	0.17	0.20	0.27	0.38	0.54	0.37		
5400	N/A	N/A	0.37	0.52	0.74	0.50	7000	0.20			0.23	0.31	0.44	0.63	0.43				
								7400			N/A	N/A	0.35	0.49	0.71	0.48			

Figure 43 - Filter Arrangements - Outdoor Models

Key:

Filter Code	Filter Size
A	16 x 20
B	20 x 20
C	16 x 25
D	20 x 25
E	25 x 25
Shaded areas are filter blockoff plates	

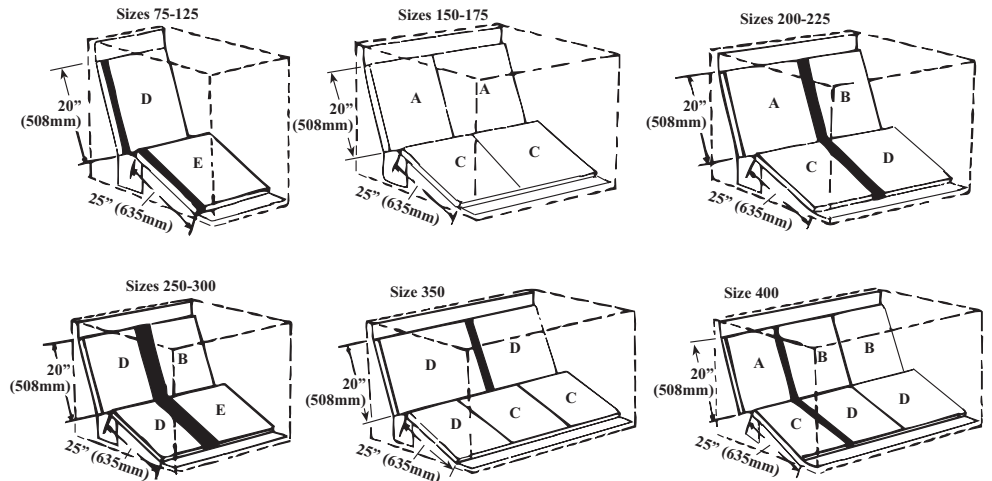

35C. Optional Dirty Filter Switch - All Models

The optional dirty filter pressure switch is used to provide warning to the user by energizing an indicator light on an optional remote console. The light indicates that the filters are in need of cleaning or changing. The adjustable, single-pole/normally open differential switch closes when an increase in pressure differential above the setpoint, is sensed across the filter bank.

This switch is located in the furnace section. See Figure 19, Item 17. After the unit is started, before continuous operation, the dirty filter switch must be set.

Instructions for Setting Dirty Filter Switch

With clean filters in place, blower doors closed, and blower in operation, decrease the pressure setting by adjusting the set screw on the switch clockwise until the filter light is energized or the screw is bottomed out. At that point, adjust the set screw three full turns counterclockwise or until the screw is top-ended. At that setpoint the filter light will be activated at approximately 50% filter blockage.

Figure 44 - Dirty Filter Switch

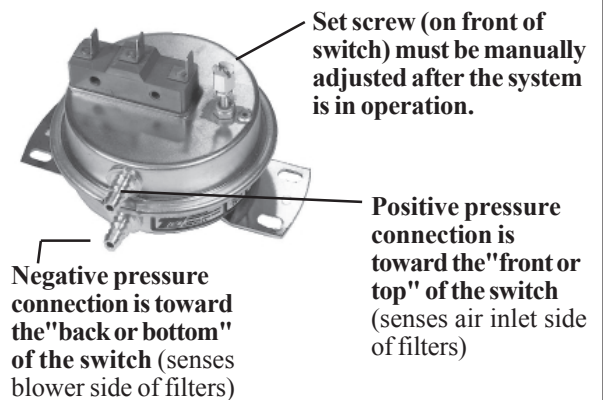

36. Optional Cooling Coil Cabinet, Option AU (Outdoor Models)

Figure 45 - Optional Cooling Coil Cabinet

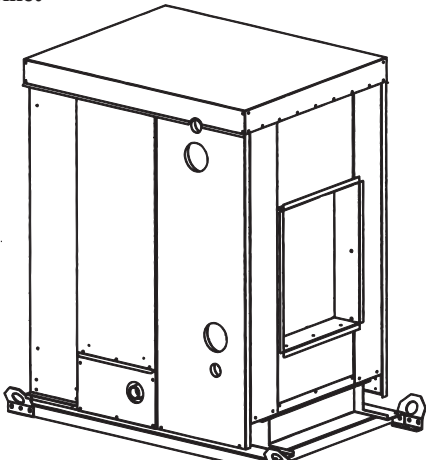

Installation Instructions

Using the parts shipped inside the cooling coil cabinet (see list on the right), follow the instructions to connect the coil cabinet to the furnace. In addition to normally required tools, a driver extension, a hammer, and bar or short length of 2x4 will be required. Silicone caulking must be field-supplied.

1. *After* the blower/furnace packaged system is in place on the roof curb or mounting rails, use a 9/16" wrench or socket to remove the lifting lugs that are on the discharge end of the system.
2. Lift the cooling coil cabinet and position it with the inlet side next to the discharge opening of the furnace. Remove the lifting lugs that are on the cooling coil cabinet.
3. Slide the cooling coil cabinet so that the duct flanges of the furnace and the cooling coil cabinet butt together (See Figure 46A).

Figure 46A -

- 1) Place the cooling coil cabinet on the curb;
- 2) remove the lifting lugs; and
- 3) slide the cabinet so that the duct flange on the cooling coil cabinet butts against the duct flange on the furnace.

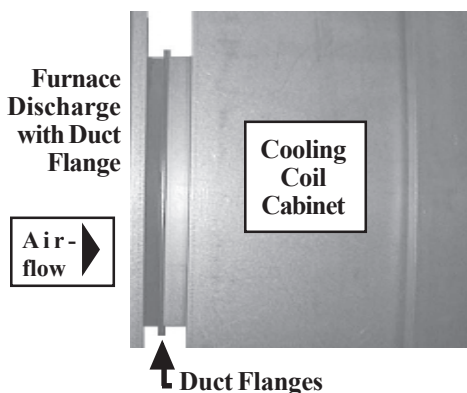

The optional cooling coil cabinet is shipped separately for attachment in the field. The cabinet accommodates either a chilled water or a refrigerant (DX) air conditioning coil. Cabinets alone have horizontal discharge but may have an attached downturn plenum for vertical discharge. Cooling coil cabinet dimensions are on page 6.

Cooling coil cabinets are lifted separately and attached to the heating/makeup air system on the roof.

WARNINGS: Do not attach the cooling coil cabinet before lifting the packaged blower/furnace system into position. Lift cooling coil cabinet separately. Do not attach the cooling coil cabinet while the furnace is in operation.

Using the parts shipped inside the cooling coil cabinet, follow the instructions below to connect the coil cabinet to the furnace.

Factory-Supplied Parts for Attaching Cabinet to Furnace

Description	Size Qty	75, 100	125	150, 175	200, 225	250, 300	350	400
Top/Bottom Duct Connectors	2	107426 14"	107427 16-3/4"	107428 21-1/4"	107429 27-3/4"	106338 36"	106339 41-1/2"	106340 47"
Side Duct Connectors	2	106395 19-1/2"	106395 19-1/2"	106395 19-1/2"	106395 19-1/2"	106395 19-1/2"	106395 19-1/2"	106395 19-1/2"
#14 x 3/4" long Sheetmetal Screws	8	105171	105171	105171	105171	105171	105171	105171
Left Side Filler Panel	1	172357	172357	172357	172357	172357	172357	172357
Right Side Filler Panel	1	172358	172358	172358	172358	172358	172358	172358
Top Filler Panel	1	172359	172359	172360	172361	172362	172363	172364
Insulation, 1"x42"x9", for Side Filler Panels	2	172546	172546	172546	172546	172546	172546	172546
#10 x 1/2" long Sheetmetal Screws	▶	11813 (19)	11813 (19)	11813 (21)	11813 (22)	11813 (24)	11813 (25)	11813 (26)
Rubber Gasket Strip, 3/32" x 1-1/8" x ▶	1	106305 34-5/8"	103605 34-5/8"	103606 40-1/8"	103607 45-5/8"	103608 53-7/8"	103609 59-3/8"	103610 64-7/8"

4. Join the Duct Flanges

- a) Use the four "U" shaped duct connector pieces and the 3/4" screws to join the duct flanges. Attach one of the 19-1/2" long side connectors to both the top and bottom duct connectors, being sure that the "U" in the metal is open to the inside.

Figure 46B - Assemble top, bottom, and one side of the duct connector pieces using the 3/4" sheetmetal screws



- b) Position the assembled connectors so that the horizontal screw holes will be in the top piece at the open side (See Figure 46C). In this position, insert the assembled top and bottom connectors (Figure 46B) into the space between the furnace and cooling coil cabinet.

Tap with a hammer first on the side, then on the top, and last on the bottom of the assembled duct connector until it is seated over the duct flanges.

Figure 46C - The end of the top connector on the "open side" of the connector assembly.



- c) Position the remaining side connector. Use the driver extension to insert the screws that attach the side connector to the top and bottom connectors. See Figure 46D.

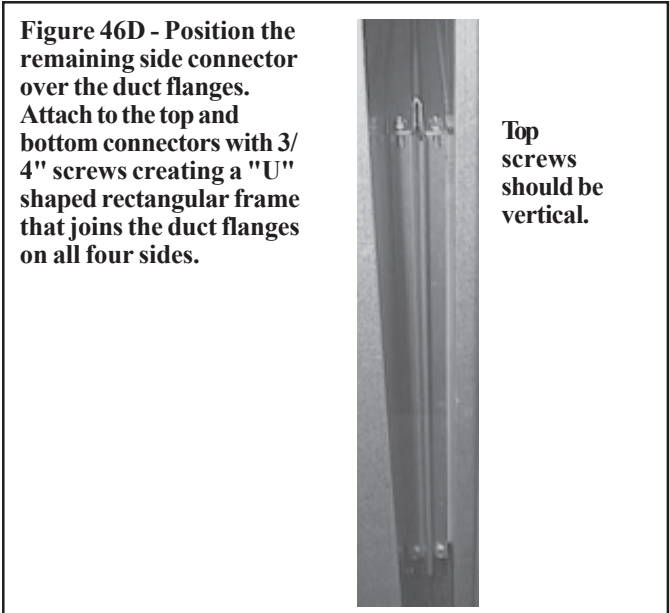

- a) Drill three 7/8" holes as instructed below. Be sure all holes are free of burrs.

First Hole:

- 1) Remove the control side door on the discharge plenum.
- 2) Locate the discharge damper motor. Connected to the motor are three wires in lengths adequate to reach the furnace section.
- 3) Refer to Figure 46E. On the leg of the downturn plenum next to the cooling coil cabinet locate the mounting screw illustrated. Measure up 6". At same centerline as the screw, drill the first 7/8" hole.

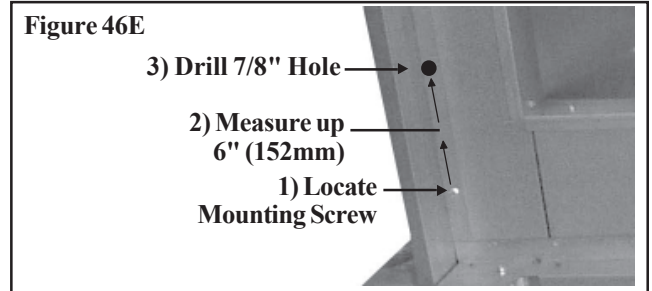

Second Hole:

- 1) Remove the cooling coil access panel(s).
- 2) Locate the coil blockoff plate. Measure up 4" (102mm) from the bottom of the blockoff plate. At that location, find the centerpoint of the blockoff plate and drill a 7/8" hole. The hole should be approximately even with the hole drilled in the downturn plenum leg.

Third Hole:

- On the cabinet leg on the entering air side of the cooling coil cabinet, measure up 10" (254mm) from the bottom pan. At that height, measure in 4" (102mm) from the edge and drill a 7/8" hole.

5. Wiring Instructions - Apply to Downturn Plenum Cabinet with Optional Discharge Dampers Only - If installing an Option AU12 or AU14 cooling coil cabinet with a downturn plenum cabinet equipped with optional discharge dampers, the damper motor wires must be connected to the terminal blocks in the furnace electrical compartment. If the coil cabinet being installed does not include a downturn plenum with a discharge damper, skip Step 5 and proceed to Step 6.

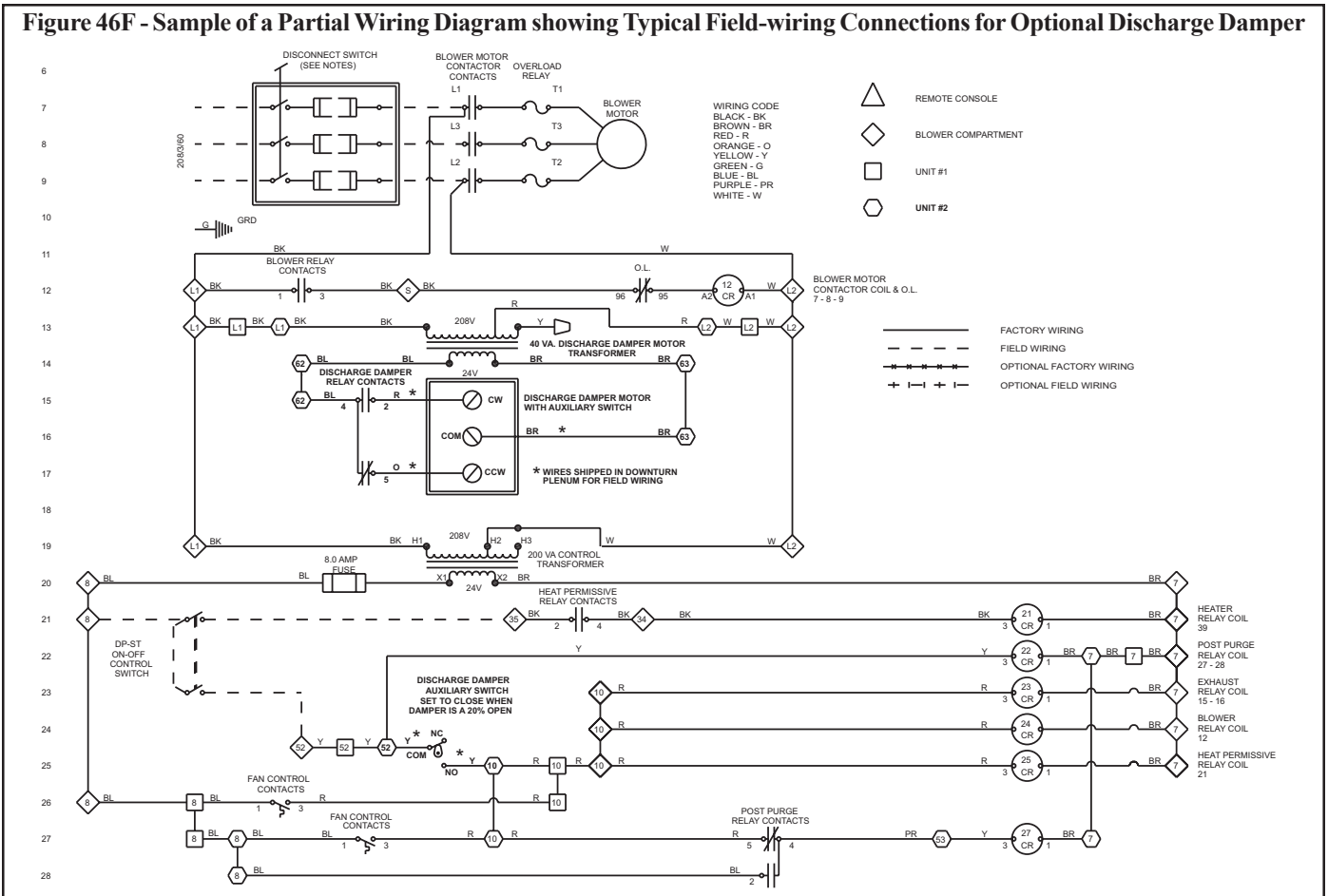

36. Optional Cooling Coil Cabinet, Option AU (cont'd)

Installation Instructions (cont'd)

b) On the outside of the furnace section (where the flanges were joined in Step 4), locate the three hole plugs. Remove the center plug exposing a 7/8" hole in the cabinet leg. See Figure 46G.

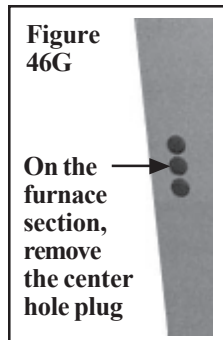

c) Run the wires attached to the damper motor 1) out through the hole in the discharge plenum leg into the cooling coil cabinet, 2) through the blockoff plate, across the coil cabinet, 3) out through the hole in the cooling coil cabinet leg, and 4) into the furnace section.

d) On the bottom of the electrical box in the furnace section, remove the hole plug that is below the terminal blocks. Route the damper motor wires up through the hole and into the electrical box. Attach according to the connections on the wiring diagram. Refer to sample in Figure 46F on page 39.

6. Prepare Cabinets to Install Filler Panels (See Figure 46H)

- At the side corners of both the cooling coil cabinet and the furnace, remove the factory-installed screws that attach the cabinet tops.
- Across the edge of the cooling coil cabinet, remove the row of screws that attach the top.

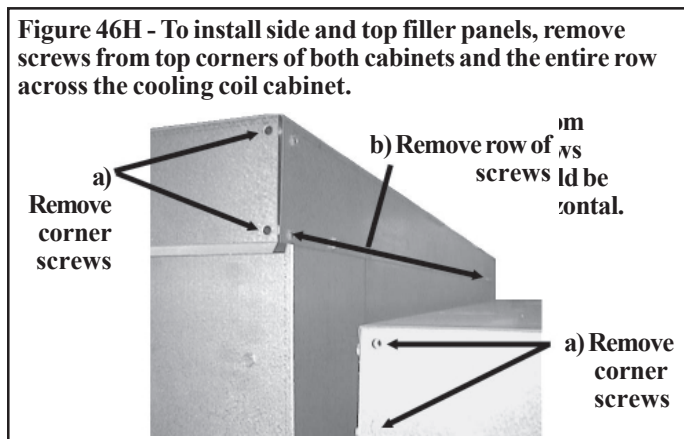

7. Install the Cabinet Side Filler Panels (See Figure 46J)

Place a piece of the supplied insulation against the inner panel of the cooling coil cabinet. Slide the filler panel into place and attach with

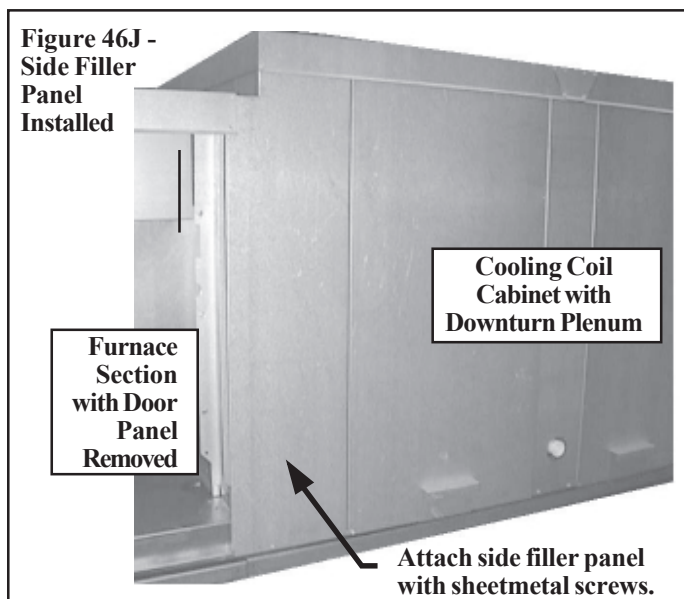

1/2" sheetmetal screws. Repeat on the other side. NOTE: It may be easier to slide the filler panels in place with the door panels removed.

8. Install the Cabinet Top Filler Panel (See Figure 46K)

- Remove the backing from the gasket strip, and adhere it along the edge of the bottom of the top filler panel.
- Slide the filler panel underneath the edge of the cooling coil cabinet top (NOTE: The edge of the top panel may have to be pulled out slightly to slide the panel underneath.) The **filler panel must be between the cooling coil cabinet top and end panel** to prevent water from leaking into the cabinet. Attach with 1/2" screws.

9. Reinsert Screws and Apply Caulking

- Reinsert any remaining screws removed in Step 5. Check for gaps between the top and side filler panels; apply caulking as needed.
- Apply silicone caulking where the cooling cabinet curb cap meets the furnace curb cap.

10. The cooling coil cabinet is installed. Follow the instructions provided by the cooling coil manufacturer to make cooling coil connections.

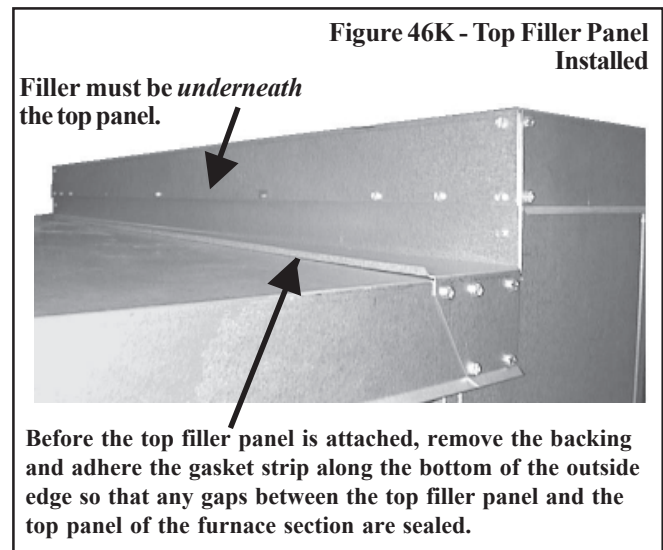

Cooling Coil Maintenance

The cooling coil cabinet is designed with easily removable panels on both sides of the cabinet to provide access for inspection and cleaning. Inspect the coil during routine maintenance and whenever the filters are changed. Check the cooling coil for build up of debris; clean as required.

SERVICE AND MAINTENANCE

WARNING: If you turn off the power supply, turn off the gas. See Hazard Levels, page 2.

This unit will operate with a minimum of maintenance. To ensure long life and satisfactory performance, a furnace that is operating under normal conditions should be inspected every four months. If the furnace is operating in an area where an unusual amount of dust or soot or other impurities are present in the air, more frequent inspection is recommended.

The following procedures should be carried out at least annually (See Paragraphs 37-39 for specific instructions.):

- Clean all dirt and grease from the primary and secondary combustion air openings.
- Clean the heat exchanger both internally and externally.
- Check the pilot burner and main burners for scale, dust, or lint accumulation. Clean as needed.
- Check the vent system for soundness. Replace any parts that do not appear sound.
- Check the wiring for any damaged wire. Replace damaged wiring. (See Paragraph 12 for replacement wiring requirements.)

NOTE: Use only factory-authorized replacement parts.

37. Burner Rack Removal Instructions

1. Turn off the gas supply.
2. Turn off the electric supply.
3. Remove control access side panel.
4. Disconnect the pilot tubing and flame sensor lead (spark pilot).
5. Mark and disconnect electric valve leads.
6. Uncouple the union in the gas supply.
7. Remove sheetmetal screws in the top corners of the burner rack assembly.
8. Pull "drawer-type" burner rack out of the furnace.

To disassemble the burner rack:

1. Remove Carryover System --
Natural Gas - remove the flash carryover system from the "manifold end" of the burner rack
NOTE: Natural gas burner racks manufactured prior to 3/95 have a lighter tube carryover system. Break the lighter tube connection at the orifice and remove the supply tubing, the drip shield and the lighter tube.
Propane Gas - break the lighter tube connection at the regulator and remove the lighter tube orifice supply tubing; remove the retaining screws in the drip shield and the shield; remove the retaining screws and slide out the lighter tube.
2. Pull main burners horizontally away from injection opening and lift out.
3. Remove manifold bracket screws and remove manifold.
4. Change main burner orifices, if necessary.
5. Remove screws and lift out pilot burner.

Follow the instructions in Paragraph 38 to clean. To re-assemble and replace, reverse the above procedures being careful not to create any unsafe conditions.

CAUTION: When cleaning, wearing eye protection is recommended.

38. Cleaning Pilot and Main Burners

In the event the pilot flame is short and/or yellow, check the pilot orifice for blockage caused by lint or dust accumulation. Remove the pilot orifice and clean with air pressure. DO NOT REAM THE ORIFICE. Check and clean the aeration slot in the pilot burner.

If the furnace is equipped with an optional spark pilot, clean the metal sensing probe and the pilot hood with an emery cloth and wipe off the ceramic insulator. Check the spark gap; spark gap should be maintained to 7/64". After the pilot is cleaned, blow any dirt away with compressed air. Main burners may be cleaned using air pressure. Use an air nozzle to blow out scale and dust accumulation from the burner ports. Alternately blow through the burner ports and the venturi. Use a fine wire to dislodge any stubborn particles. Do not use anything that might change the port size.

Clean the burner rack carryover systems with air pressure.

39. Cleaning the Heat Exchanger

To clean the outer surfaces (circulating air side) of the heat exchanger, gain access by removing the inspection panels in the ductwork or remove the

ductwork. Depending on whether or not the furnace is designed for high CFM (Model prefix "H"), there may be directional baffles between the heat exchanger tubes. The standard furnace has baffles between the heat exchanger tubes as shown in Figure 46. (High CFM furnaces have only the top baffle support which does not need to be removed for cleaning.) To remove the baffles, remove the screws marked "A" in Figure 45, and slide each baffle forward. Use a brush and/or an air hose to remove accumulated dust and grease deposits from the heat exchanger tubes and the baffles. Re-install the baffles by sliding them into the rear slot and replacing the screw. The inner surfaces (combustion air side) of the heat exchanger can be reached for cleaning with the burner rack removed. (See Paragraph 37.) An air hose; an 18-24" long, 1/2" diameter furnace brush (or heavy wire with steel wool securely attached); a flashlight; and a mirror are needed. The required procedure depends on the date of

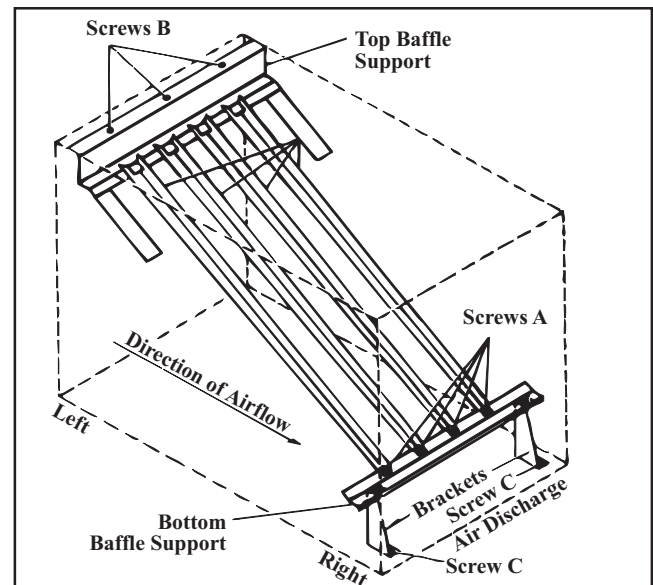

Figure 47 - When cleaning outer heat exchanger surface remove directional air baffles. Remove Screws "A" and slide baffles out. Clean and replace all baffles. NOTE: High CFM furnaces do not have directional air baffles.

manufacture and whether or not the furnace is rated for high (80%) efficiency. Furnaces designed to provide high efficiency heating have "V" shaped baffles in the top of each heat exchanger tube. Follow these instructions to remove these baffles when cleaning the inner surfaces of the heat exchanger.

NOTE: High efficiency furnaces manufactured prior to 3/95 have a "C" prefix in their model designation. All furnaces manufactured beginning 3/95 are designed for high efficiency and include these heat exchanger "V" baffles.

39. Cleaning the Heat Exchanger (cont'd)

Instructions to Remove Heat Exchanger "V" Baffles:

Outdoor, Gravity Vent Models (See Figure 48)

- 1) Remove the ends of the flue gas collection box. On the control side of the furnace, remove the block-off plate to gain access to the

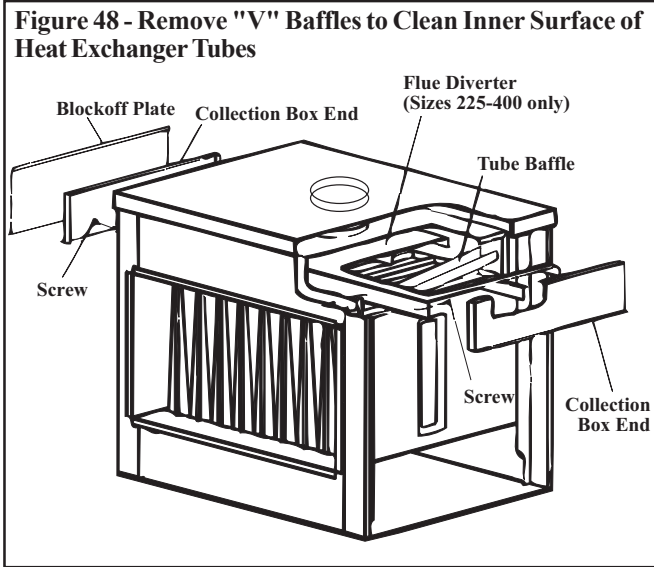

- collection box end.
- 2) **Sizes 75-175** -- Remove one of the tube baffle retaining angles on each inside wall of the collection box. Each tube baffle angle has one screw.
 - Sizes 200-400** -- Remove the flue diverter. Remove the screw at each end and slide the flue diverter out of the furnace.
 - 3) Pull the "V" baffles out of the heat exchanger.

Outdoor, Power Vent Models

- 1) Remove the ends of the flue gas collection box. On the control side of the furnace, remove the venter assembly and the flue outlet duct to gain access to the collection box end.
- 2) **Sizes 125-300** -- Remove one of the tube baffle retaining angles on each inside wall of the collection box. Each tube baffle angle has one screw.

Size 400 -- Remove the inner baffle from the flue collection box. On the control side, align the inner baffle with the slot in the collection box edge. Pull the inner baffle until it clears the heat exchanger. Remove the screw at each end and slide the flue diverter out of the furnace.

- 3) Pull the "V" baffles out of the heat exchanger.

Indoor, Gravity Vent Models (See Figure 49)

- 1) Remove the screws (the number varies depending on unit size) along the bottom of the front baffle and the three on each end. Slide the

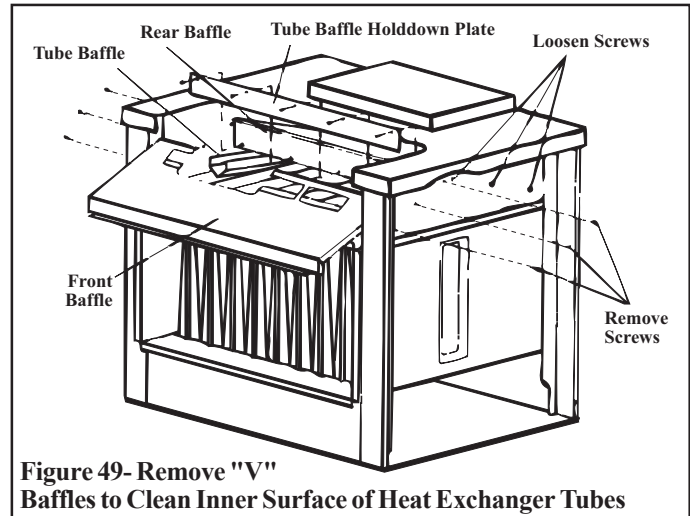

Figure 49- Remove "V" Baffles to Clean Inner Surface of Heat Exchanger Tubes

- front baffle out of the furnace.
- 2) Remove the screws that attach the tube baffle hold-down plate to the rear flue baffle.
 - 3) Pull the "V" baffles out of the heat exchanger.

All Models -- Clean the inner surfaces of the heat exchanger from beneath using the brush to "scrub" the tube walls to remove any accumulated dust, rust and/or soot. Clean the "V" tubes and re-assemble the heat exchanger and the furnace.

Check the furnace for proper operation.

40. Troubleshooting

Troubleshooting the System

TROUBLE	PROBABLE CAUSE	REMEDY
Pilot will not light (match-lit system)	<ol style="list-style-type: none"> 1. Manual valve not open. 2. Air in gas line. 3. Incorrect lighting procedure 4. Dirt in pilot orifice. 5. Gas pressure too high or too low. 6. Bent or kinked pilot tubing. 7. Failed E.C.O. device 	<ol style="list-style-type: none"> 1. Open manual valve. 2. Bleed gas line. 3. Follow instructions on junction box cover 4. Remove and clean with compressed air or solvent (do not ream). 5. Adjust supply pressure. (See Paragraph 11.) 6. Replace tubing. 7. Replace E.C.O. device.
Pilot lights, main valve will not open (Match-lit system)	<ol style="list-style-type: none"> 1. Power not turned on or thermostat not calling for heat. 2. Circuit to valve open. 3. Faulty transformer. 4. Faulty or dirty thermocouple or safety pilot switch; or failed E.C.O. device 5. Faulty thermostat (see manufacturer's instructions) 6. Faulty valve. 7. High gas pressure. 8. Activated blocked vent switch. 	<ol style="list-style-type: none"> 1. Turn on power; check fuses; turn on thermostat. 2. Check wiring and connections at transformer and thermostat. 3. Replace the transformer. 4. Clean and test with millivolt meter or test kit. Replace defective part. 5. Replace thermostat. 6. Replace valve or magnetic head. 7. Adjust supply pressure. (See Paragraph 11.) 8. Correct venting problem. Reset switch.
Venter motor will not start (power-system)	<ol style="list-style-type: none"> 1. No power to the furnace. 2. No 24-volt power to venter relay. 3. Venter relay defective. 4. Defective motor or capacitor. 	<ol style="list-style-type: none"> 1. Turn on power, check supply fuses or circuit breaker. 2. Turn up thermostat, check control transformer output. Check for loose or improper wire 3. Replace. 4. Replace defective part.

TROUBLE	PROBABLE CAUSE	REMEDY
Pilot will not light (Spark ignition system) (Ventur operating on power-vented models)	<ol style="list-style-type: none"> Manual valve not open. Air in gas line. Dirt in pilot orifice. Gas pressure too high or too low. Kinked pilot tubing. Pilot valve does not open. No spark: <ol style="list-style-type: none"> Loose wire connections Transformer failure. Incorrect spark gap. Spark cable shorted to ground. Spark electrode shorted to ground. Drafts affecting pilot. Ignition control not grounded. Faulty ignition controller. Optional lockout device interrupting control circuit by above causes. Faulty combustion air proving switch. Activated blocked vent switch (indoor system) 	<ol style="list-style-type: none"> Open manual valve. Bleed gas line. Remove and clean with compressed air or solvent (do not ream). Adjust supply pressure. (See Paragraph 11). Replace tubing. If 24 volt available at valve, replace valve. <ol style="list-style-type: none"> Be certain all wires connections are solid. Be certain 24 volts is available. Maintain spark gap at 7/64". Replace worn or grounded spark cable. Replace pilot if ceramic spark electrode is cracked or grounded. Make sure all panels are in place and tightly secured to prevent drafts at pilot. Make certain ignition control is grounded to furnace chassis. If 24 volt is available to ignition controller and all other causes have been eliminated, replace ignition control. Reset lockout by interrupting control at thermostat. Replace combustion air proving switch. Correct venting problem. Reset switch.
Pilot lights, main valve will not open (Spark ignition system)	<ol style="list-style-type: none"> Manual valve not open. Main valve not operating. <ol style="list-style-type: none"> Defective valve. Loose wire connections. Ignition control does not power main valve. <ol style="list-style-type: none"> Loose wire connections. Flame sensor grounded. (Pilot lights - spark continues) Gas pressure incorrect. Cracked ceramic at sensor. Faulty ignition controller. Poor microamp signal 	<ol style="list-style-type: none"> Open manual valve. <ol style="list-style-type: none"> If 24 volt is measured at valve connections and valve remains closed, replace valve. Check and tighten all wiring connections. <ol style="list-style-type: none"> Check and tighten all wiring connections. Be certain flame sensor lead is not grounded or insulation or ceramic is not cracked. Replace as required. Adjust gas pressure. (See Paragraph 11.) Replace sensor. See Paragraph 25. If all checks indicate no other cause, replace ignition controller. Do not attempt to repair the ignition controller. This device has no field replaceable parts. Adjust pilot regulator
No heat (Heater Operating)	<ol style="list-style-type: none"> Dirty filters in blower system.. Incorrect manifold pressure or orifices. Cycling on limit control. Improper thermostat location or adjustment. Belt slipping on blower 	<ol style="list-style-type: none"> Clean or replace filters. Check manifold pressure (See Paragraph 11). Check air throughput (See Paragraph 13). See thermostat manufacturer's instructions. Adjust belt tension
Cold air On Startup	<ol style="list-style-type: none"> Fan control improperly wired Defective fan control. 	<ol style="list-style-type: none"> Connect as per wiring diagram. Replace fan control.
During Operation	<ol style="list-style-type: none"> Incorrect manifold pressure. Blower set for too low temperature rise. 	<ol style="list-style-type: none"> Check manifold line pressure (See Paragraph 11). Slow down blower or increase static pressure.
Motor will not run	<ol style="list-style-type: none"> Circuit open Fan Control inoperative Contacter inoperative Defective motor. 	<ol style="list-style-type: none"> Check wiring and connections. Replace fan control. Replace contactor. Replace motor.
Motor turns on and off while burner is operating	<ol style="list-style-type: none"> Fan control heater element improperly wired. Defective fan control Motor overload device cycling 3-phase motor rotating in opposite direction 	<ol style="list-style-type: none"> Connect as per wiring diagram Replace fan control Check motor load against motor rating plate. Replace motor or overload device. Interchange two legs of supply connections.
Motor cuts out on overload	<ol style="list-style-type: none"> Improper motor pulley adjustment Improper static pressure on duct system Low voltage 	<ol style="list-style-type: none"> See instructions on air throughput (See Paragraph 13). Adjust dampers in duct system. Check power supply.

Troubleshooting the Optional Evaporative Cooling Module (Refer to Paragraph 33.)

WARNING: Disconnect the power before servicing the cooling module. Failure to do so can cause electrical shock, personal injury or death.

Problem	Probable Cause	Remedy
Pump does not run. Unit is calling for cooling (i.e. console control switch is in cooling position) and reservoir is full.	<ol style="list-style-type: none"> Electrical connections Electric float switch on pump Dirty pump Defective pump 	<ol style="list-style-type: none"> Verify all electrical connections. See Wiring Diagram. Check position of the actuators on the electric float switch. Clean pump. See Figure 40. Replace pump.
Required water level (3") not maintained (pump and float control system)	<ol style="list-style-type: none"> Float valve Optional drain and fill valves Incorrect overflow pipe nipple - should be 3-1/2" Drain leaking 	<ol style="list-style-type: none"> Adjust float valve. See Filling and Adjusting Water Level. Check valve for proper operation. See Figure 33. Replace pipe nipple. Tighten drain plug.
Water running off of media pads	<ol style="list-style-type: none"> Excessive water flow Media needs cleaned or replaced. 	<ol style="list-style-type: none"> See adjust water flow instructions. Clean or replace media pads.

Troubleshooting the Optional Evaporative Cooling Module (cont'd)

Problem (cont'd)	Probable Cause (cont'd)	Remedy (cont'd)
Water not distributing evenly	<ol style="list-style-type: none"> 1. Distribution line clogged 2. Holes in distribution line turned 3. Incorrect voltage to pump 	<ol style="list-style-type: none"> 1. Flush distribution line. See Evap Cooling Module Maintenance. 2. Check position of distribution line. Holes should be spraying upward. If not positioned with holes up, adjust position of line. 3. Check voltage at pump terminal in cooling module junction box.
Media pads becoming clogged and discolored quickly (scale/salt deposits) and/or rapid deterioration of the float switch	<ol style="list-style-type: none"> 1. Bleed off line clogged or inadequate bleed off (pump and float control system) 2. Excessive water flow 	<ol style="list-style-type: none"> 1. Clean bleed line (See Figure 35). A uniform build-up of minerals on the entering air face of the media indicates insufficient bleed off. Increase the rate until the mineral deposits dissipate. 2. See Adjusting Water Flow.
Water blowoff from media pads	<ol style="list-style-type: none"> 1. Media pads installed incorrectly 2. Requires moisture elimination pad (over 600 FPM) 3. Water level not 3 inches (pump and float control system) 	<ol style="list-style-type: none"> 1. Install media pads correctly. See Cooling Module Maintenance. 2. Install moisture elimination pad. Consult factory. 3. See second problem listed above (Required water level)

MAINTENANCE AND TROUBLESHOOTING REFERENCES:

- For additional maintenance and service information, refer to specific paragraphs in the Installation and Operating Section or the Optional Equipment Section of this booklet. (See Index on page 1.)
- For Troubleshooting Guide for Optional Electronic Modulation Gas Control Options with 20% Turndown (Option AG39 or AG40), see page 26.
- For replacement parts, refer to Form RZ 705 for indoor units or Form RZ 707 for outdoor units.

FOR SERVICE OR REPAIR, FOLLOW THESE STEPS IN ORDER:

FIRST: Contact the installer.

Name _____

Address _____

Phone _____

SECOND: Contact the nearest distributor (See Yellow Pages). If no listing, contact Authorized Factory Representative, 1-800-695-1901 (Press 1).

THIRD: Contact: REZNOR®/ Thomas & Betts Corporation
 150 McKinley Avenue
 Mercer, PA 16137
 Phone: (724) 662-4400

Model No. _____

Unit Serial No. _____

Date of Installation _____



Thomas & Betts

©2001 Thomas & Betts Corporation, All rights reserved.

Printed in the U.S.A.

MANUFACTURER OF GAS, OIL, ELECTRIC HEATING AND VENTILATING SYSTEMS

Trademark Note: Reznor® is registered in the United States and other countries.

1-800-695-1901; www.ReznorOnline.com

6/01 Form 403 (Version B.3)