

IMPORTANT

1. Always include complete heater model and serial number so that any specification change can be considered for parts shipment. It can save time and expense.
2. Specifications are subject to change without notice.
3. We reserve the right to substitute functional replacements.
4. Order either by Kit or Component Part No.

Replacement Parts

Form RZ-NA-P-X/XE/RX/RPV

Obsoletes Form RGM 705 (Version A)

APPLIES TO: Replacement Parts for Models listed in the Index including Models with prefix "C", "H", and "HC"



Index Reference by Page No.	Indoor		Outdoor				Indoor	Outdoor
	Duct Furnace	Packaged Systems	Duct Furnaces		Packaged Systems (Models discontinued as of 1990)		Unit Heaters (Obsolete)	Evaporative Cooler (Obsolete)
	X	XE/XJ	RX	RPV	RXE/RXJ	RPBE/RPVE/RPVJ/REB/REBJ	UA/XA/ XB*	RAM
Model Series Designations (including Models with prefix "C", "H", or "HC")	X	XE/XJ	RX	RPV	RXE/RXJ	RPBE/RPVE/RPVJ/REB/REBJ	UA/XA/ XB*	RAM
Baffles (Heat Exchanger)	10	10	10	10	10	10	--	--
Blower	--	11	--	--	11	11	--	--
Burner Rack and Carryovers	8	8	8	8	8	8	8**	--
Cabinet Parts (Blower)	--	12	--	--	13	13	--	--
Cabinet Parts (Heater)	4	4	4	6	4	4, 6	--	28
Carryover Regulator	8	8	8	8	8	8	--	--
Condensate Drain Kit	27	27	27	27	--	--	--	--
Contactors	--	14	--	--	14	14	--	--
Damper and Damper Controls	--	20-21	--	--	20-21	20-21	--	--
Door Latch Kit	--	13	--	--	13	13	--	--
Downturn Plenum Cabinet	--	--	--	--	20	20	--	--
Drives	--	19	--	--	19	19	--	--
Electrical Components	22-25	22-25	22-25	22-25	22-25	22-25	--	28
Fan Blades	--	--	--	--	--	--	18	--
Fill & Drain Kits (Option CT)	--	--	--	--	--	--	--	28
Filters and Filter Racks	--	12	--	--	13	13	--	28
Firestat	--	23	--	--	23	23	--	--
Flue Restrictors	--	--	6	--	6	6	--	--
Freezestat	--	24	--	--	24	24	--	--
Heat Exchanger	10	10	10	10	10	10	--	--
Limit Controls & Shields	22	22	22	22	22	22	--	--
Manifolds	8	8	8	8	8	8	--	--
Motors (Blower or Fan)	--	14-16	--	--	16-18	16-18	18	--
Pilots	26	26	26	27	26	26-27	26	--
Pressure Switch (air proving)	--	--	24	24	24	24	--	--
Pressure Switch (combustion air)	--	--	--	7, 22	--	7, 22	--	--
Pressure Switch (dirty filter)	--	24	--	--	24	24	--	--
Pressure Switch (gas)	23	23	23	23	23	23	--	--
Relays	23-24	23-24	23-24	23-24	23-24	23-24	23-24	--
Remote Console (Option RC)	25	25	25	25	25	25	--	--
Serial Number Designation	2	2	2	2	2	2	2	--
Starters & Starter Heaters	--	14-16	--	--	16-18	16-18	--	--
Switch, Blocked Vent	22	22	--	--	--	--	--	--
Switches, Disconnect & Toggle	25	25	25	25	25	25	25	--
Tape for Curbs	--	--	27	27	27	27	--	--
Transformer	24	24	24	24	24	24	--	--
***Valves (Shutoff)	8	8	8	8	8	8	8	--
Venters	--	--	--	6	--	6	--	--
Vertical Vent Kit (Option CC3)	--	--	--	6	--	6	--	--
Weatherhood (Outside air hood)	--	--	--	--	20	20	--	--
Z-Baffles (Option ZZ)	--	--	4-5	--	4-5	--	--	--

* Replacement parts for obsolete unit heaters are limited. Cabinet parts are not available. ** Not available for Model UA.

REFERENCES:

Replacement Parts and Service Forms, Form RZ-NA

P-PILOTS, Pilots

P-STATS, Thermostats and Accessories

P-GC, Gas Conversion

P-LTR-TUBES, Burner Rack Carryover and Lighter Tubes

P-RG/RP/RBL, Parts for Model Series RG and RP

P-FAN-LIMIT, Fan and Limit Controls

***P-VALVES, Serial Nos., Gas Valves, Ignition Controllers, and Maxitrol Gas Controls

P-VENTER, Power Venter for Model Series X and XE

737, Parts for Model PAK

CP-X-CONV, Convert Model Series X and RX with G19 or T32 to G770

CP-RPV-CONV, Convert Model Series RPV with G29 to G770

CP-RPV-PS, Pressure Switch Kit for Model Series RPV

CP-X/SC-IGN, Convert Model Series X and RX with G60 to G770

CP-EEDU/RPV/XLB-IGN, Convert Model Series RPV with G60 to G770

Installation/Operation Forms for currently manufactured Models, Form RZ-NA

I-OUTDOOR-DUCT, Models RX and RPV

I-XE/RGB/RPB, Model XE

I-X, Model X

Duct Furnace Rating Plate



REZNOR
MERCER, PA. USA 16137

DUCT FURNACE CATEGORY I
FOR INDUSTRIAL/COMMERCIAL USE ONLY
ANSI Z83.8 [AA] - [A] CGA 2.6 [AA'] - M [A'] DUCT FURNACE

MODEL [B] [C]
SERIAL NO. [D]

[E] VOLTS [E] PH [E] HZ MAXIMUM TOTAL INPUT [E] AMPS
TYPE OF GAS: [F] [G]
ORIFICE SIZE [J] DRILL HAS BEEN FACTORY ADJUSTED
FOR USE AT [H] FEET [I] METERS OF ALTITUDE.

	SEA LEVEL	ALT. ADJUSTED
NORMAL INPUT	[R]	[K] BTU/HR.
OUTPUT CAPACITY	[S]	[L] BTU/HR.
MINIMUM INPUT (2, M, MB, MV MODELS)	[T]	[M] BTU/HR.
NORMAL MANIFOLD PRESSURE		[N] IN.W.C.
MIN. PERMISSIBLE GAS SUPPLY PRESSURE FOR PURPOSE OF INPUT ADJUSTMENT.		[O] IN.W.C.
MAXIMUM THROUGHPUT	[P] C.F.M.	
MINIMUM THROUGHPUT	[Q] C.F.M.	

CLEARANCES TO COMBUSTIBLE CONSTRUCTION: VENT CAP-10', BOTTOM- 3", FLUE CONNECTION-6", SERVICE SIDE- WIDTH OF UNIT, OPPOSITE SIDE-6" THIS UNIT SHALL BE INSTALLED ON THE POSITIVE PRESSURE SIDE OF THE AIR CIRCULATING BLOWER.
THIS UNIT MAY BE INSTALLED DOWNSTREAM FROM A REFRIGERATION SYSTEM (USE DRAIN OPTION CS1).
THIS UNIT MAY BE USED WITH DUCTS.
THIS UNIT IS FOR OUTDOOR INSTALLATION ONLY.
MINIMUM OPERATIONAL AMBIENT AIR TEMPERATURE: -40 DEG. F
THIS UNIT IS FOR USE WITH NATURAL GAS AND PROPANE. A CONVERSION KIT AS SUPPLIED BY THE MANUFACTURER, SHALL BE USED TO CONVERT THIS DUCT FURNACE TO THE ALTERNATE FUEL.
FOR ALTERNATE INSTALLATIONS USE THE LATEST EDITIONS OF THE APPROPRIATE STANDARD LISTED BELOW:
FOR AIRCRAFT HANGARS USE STANDARD ANSI/NFPA 409
FOR PARKING STRUCTURES USE STANDARD ANSI/NFPA 88A
FOR REPAIR GARAGES USE STANDARD ANSI/NFPA 88B

Key to Duct Furnace Rating Plate

- A = Standard
- B = Model and Size
- C = Date of Manufacturer
- D = Serial No.
- E = Volts/PH/Hz/Amps
- F & G = Natural or Propane Gas
- H & I = Altitude
- J = Orifice Drill Size
- K = Normal Input (altitude adjusted)
- L = Thermal Output (altitude adjusted)
- M = Minimum Input (altitude adjusted)
- N = Normal Manifold Pressure
- O = Minimum Gas Supply Pressure
- P = Maximum Air Throughput
- Q = Minimum Air Throughput
- R = Normal Input (sea level)
- S = Thermal Output (sea level)
- T = Minimum Input (sea level)

De-Coding a Serial No.

Sample: SAZJ 66 K1 N 12345 MV3

1 | 2 | 3 | 4 | 5 | 6 | 7

- 1 = Stainless steel heat exchanger (with an aluminized heat exchanger, there is no letter suffix)
- 2 = Date code (see page 3)
- 3 = Pilot code (Reference Form RZ 714)
- 4 = Valve code (Reference Form RZ 714)
- 5 = N is natural gas; L is propane gas
- 6 = Consecutive number
- 7 = Maxitrol system (optional)

Replacement Parts Tag - Each unit has a replacement parts tag that includes the Model No. and the Serial No. as well as a list of original common replacement parts. Always provide the full model and serial numbers when ordering replacement parts.

Blower Cabinet Rating Plate on Certified Packaged Units (see table on page 3)



REZNOR
MERCER, PA., U.S.A. 16137

PACKAGED DUCT FURNACE
FOR INDUSTRIAL/COMMERCIAL USE ONLY
DESIGN CERTIFIED FOR A.G.A. REQUIREMENTS UNDER
[A] PACKAGED DUCT FURNACE STANDARD

MODEL [B] [C]
SERIAL NO. [D] HP

[E] VOLTS [E] PH [E] HZ MAXIMUM TOTAL INPUT [E] AMPS
IF EQUIPPED WITH R.E.C. OPTION, ADD [V] AMPS
EQUIPPED FOR OPERATION AT AN AIR FLOW OF [F] SCFM
AGAINST A STATIC PRESSURE OF [G] INCHES WATER COLUMN.
DRIVE NO. [H] WIRING DIAGRAM [I]
SEE MANUFACTURER'S INSTRUCTIONS FOR OTHER AIR FLOW CAPACITIES.
FILTERS, WHEN USED, MUST BE INSTALLED EXTERNAL TO THE HEATING CASING.
REFER TO THE RATING PLATE OF THE DUCT FURNACE FOR ADDITIONAL INFORMATION.

Key to Cabinet Rating Plate

- A = Standard
- B = Model
- C = Date of Manufacture
- D = Motor Horsepower
- E = Volts/Phase/Hertz/Amps
- F = SCFM
- G = Static Pressure (w.c.)
- H = Drive AM Option Code
- I = Wiring Diagram No.

Identification Plate on Blower Cabinets Manufactured Prior to Package Certification (see dates on page 3)

	MODEL NUMBER		SERIAL NUMBER	
	DRIVE NO.		WIRING DIAGRAM NO.	
	CFM _____ AT _____ IN. W.C. MAX. E.S.P. AND _____ HP		HP	
	VOLTS	PHASE	HERTZ	AMPERES

HP Codes

Single-Speed Motors		2-Speed Motors	
Code	HP	Code	HP
05	1	20	1/.44
06	1-1/2	21	1.5/.68
07	2	22	2/.88
08	3	23	3/1.3
09	5	24	5/2.2
11	7-1/2	25	7.5/3.3
12	15	26	10/4.4
13	10		
14	20		

First Element of the Serial Number (See page 2) - Date of Manufacture

Year	Jan	Feb	Mar	Apr	May	June	July	Aug	Sept	Oct	Nov	Dec
1963	OA	OB	OC	OD	OE	OF	OG	OH	OI	OJ	OK	OL
1964	PA	PB	PC	PD	PE	PF	PG	PH	PI	PJ	PK	PL
1965	QA	QB	QC	QD	QE	QF	QG	QH	QI	QJ	QK	QL
1966	RA	RB	RC	RD	RE	RF	RG	RH	RI	RJ	RK	RL
1967	SA	SB	SC	SD	SE	SF	SG	SH	SI	SJ	SK	SL
1968	TA	TB	TC	TD	TE	TF	TG	TH	TI	TJ	TK	TL
1969	UA	UB	UC	UD	UE	UF	UG	UH	UI	UJ	UK	UL
1970	VA	VB	VC	VD	VE	VF	VG	VH	VI	VJ	VK	VL
1971	WA	WB	WC	WD	WE	WF	WG	WH	WI	WJ	WK	WL
1972	XA	XB	XC	XD	XE	XF	XG	XH	XI	XJ	XK	XL
1973	YA	YB	YC	YD	YE	YF	YG	YH	YI	YJ	YK	YL
1974	ZA	ZB	ZC	ZD	ZE	ZF	ZG	ZH	ZI	ZJ	ZK	ZL
1975	AAA	AAB	AAC	AAD	AAE	AAF	AAG	AAH	AAI	AAJ	AAK	AAL
1976	ABA	ABB	ABC	ABD	ABE	ABF	ABG	ABH	ABI	ABJ	ABK	ABL
1977	ACA	ACB	ACC	ACD	ACE	ACF	ACG	ACH	ACI	ACJ	ACK	ACL
1978	ADA	ADB	ADC	ADD	ADE	ADF	ADG	ADH	ADI	ADJ	ADK	ADL
1979	AEA	AEB	AEC	AED	AEE	AEF	AEG	AEH	AEI	AEJ	AEK	AEL
1980	AFA	AFB	AFC	AFD	AFE	AFG	AFH	AFI	AFJ	AFK	AFK	AFL
1981	AGA	AGB	AGC	AGD	AGE	AGF	AGG	AGH	AGI	AGJ	AGK	AGL
1982	AHA	AHB	AHC	AHD	AHE	AHF	AHG	AHH	AHI	AHJ	AHK	AHL
1983	AIA	AIB	AIC	AID	AIE	AIF	AIG	AIH	AII	AIJ	AIK	AIL
1984	AJA	AJB	AJC	AJD	AJE	AJF	AJG	AJH	AJI	AJJ	AJK	AJL
1985	AKA	AKB	AKC	AKD	AKE	AKF	AKG	AKH	AKI	AKJ	AKK	AKL
1986	ALA	ALB	ALC	ALD	ALE	ALF	ALG	ALH	ALI	ALJ	ALK	ALL
1987	AMA	AMB	AMC	AMD	AME	AMF	AMG	AMH	AMI	AMJ	AMK	AML
1988	ANA	ANB	ANC	AND	ANE	ANF	ANG	ANH	ANI	ANJ	ANK	ANL
1989	AOA	AOB	AOC	AOD	AOE	AOE	AOG	AOH	AOI	AOJ	AOK	AOL
1990	APA	APB	APC	APD	APE	APF	APG	APH	API	APJ	APK	APL
1991	AQA	AQB	AQC	AQD	AQE	AQF	AQG	AQH	AQI	AQJ	AQK	AQL
1992	ARA	ARB	ARC	ARD	ARE	ARF	ARG	ARH	ARI	ARJ	ARK	ARL
1993	ASA	ASB	ASC	ASD	ASE	ASF	ASG	ASH	ASI	ASJ	ASK	ASL
1994	ATA	ATB	ATC	ATD	ATE	ATF	ATG	ATH	ATI	ATJ	ATK	ATL
1995	AUA	AUB	AUC	AUD	AUE	AUF	AUG	AUH	AUI	AUJ	AUK	AUL
1996	AVA	AVB	AVC	AVD	AVE	AVF	AVG	AVH	AVI	AVJ	AVK	AVL
1997	AWA	AWB	AWC	AWD	AWE	AWF	AWG	AWH	AWI	AWJ	AWK	AWL
1998	AXA	AXB	AXC	AXD	AXE	AXF	AXG	AXH	AXI	AXJ	AXK	AXL
1999	AYA	AYB	AYC	AYD	AYE	AYF	AYG	AYH	AYI	AYJ	AYK	AYL
2000	AZA	AZB	AZC	AZD	AZE	AZF	AZG	AZH	AZI	AZJ	AZK	AZL
2001	BAA	BAB	BAC	BAD	BAE	BAF	BAG	BAH	BAI	BAJ	BAK	BAL
2002	BBA	BBB	BBC	BBD	BBE	BBF	BBG	BBH	BBI	BBJ	BBK	BBL
2003	BCA	BCB	BCC	BCD	BCE	BCF	BCG	BCH	BCI	BCJ	BCK	BCL
2004	BDA	BDB	BDC	BDD	BDE	BDF	BDG	BDH	BDI	BDJ	BDK	BDL
2005	BEA	BEB	BEC	BED	BEE	BEF	BEG	BEH	BEI	BEJ	BEK	BEL
2006	BFA	BFB	BFC	BFD	BFE	BFF	BFG	BFH	BFI	BFJ	BFK	BFL
2007	BGA	BGB	BGC	BGD	BGE	BGF	BGG	BGH	BGI	BGJ	BGK	BGL
2008	BHA	BHB	BHC	BHD	BHE	BHF	BHG	BHH	BHI	BHJ	BHK	BHL
2009	BIA	BIB	BIC	BID	BIE	BIF	BIG	BIH	BII	BIJ	BIK	BIL
2010	BJA	BJB	BJC	BJD	BJE	BJF	BJG	BJH	BJI	BJJ	BJK	BJL
2011	BKA	BKB	BKC	BKD	BKE	BKF	BKG	BKH	BKI	BKJ	BKK	BKL
2012	BLA	BLB	BLC	BLD	BLE	BLF	BLG	BLH	BLI	BLJ	BLK	BLL
2013	BMA	BMB	BMC	BMD	BME	BMF	BMG	BMH	BMI	BMJ	BMK	BML
2014	BNA	BNB	BNC	BND	BNE	BNF	BNG	BNH	BNI	BNJ	BNK	BNL
2015	BOA	BOB	BOC	BOD	BOE	BOF	BOG	BOH	BOI	BOJ	BOK	BOL

Date Duct Furnace Series was Introduced or Recertified

The series is identified in the Model No. of the unit. The number following the model of the heater is the series number (Example: RX300-6; "6" is the Series No.). Replacement parts may be affected by the introduction of a new series.

Models	Series 3	Series 5	Series 6	Series 7	Series 8
RPV	5/76	1/82	11/86	--	5/95
CRPV	--	1/85	11/86	--	--
X	--	6/80	5/84	8/90	5/95
CX	--	--	8/84	--	--
RX	--	6/80	8/84	--	5/95
CRX	--	--	1/85	--	5/95

Date of Packaged Unit Certification

Model Introduced
XE 3/96

Discontinued Models in this booklet:

(H)CRPV (H)(C)REB REBJ
(H)CX (H)(C)RPBE UA
(H)CXE (H)(C)RPVE XA
(H)(C)RXE RPVJ XB
RXJ RAM

CODES 1-10 Exterior Furnace Cabinet Parts for Indoor Model Series X (also the furnace section of Model Series XE)

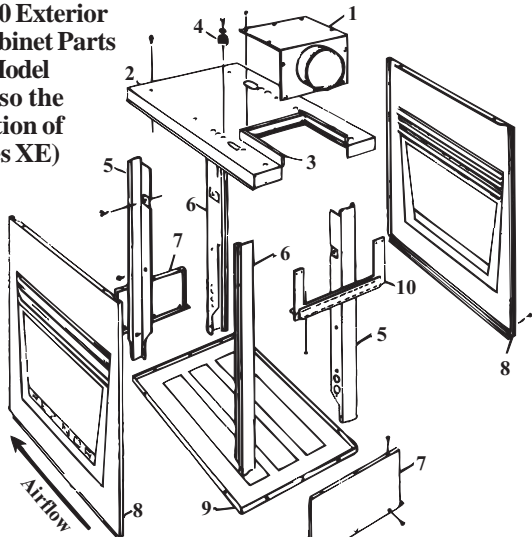

CODES 11-14 Drafthood Parts for Indoor Model Series X (also the furnace section of Model Series XE)

NOTE: Effective 4/91, all Model X and XE units include a blocked vent switch requiring mounting holes in the drafthood side (Code 14B). If the drafthood side is being replaced in a unit not equipped with the blocked vent switch, a patch plate with gasket must cover the blocked vent switch mounting holes.

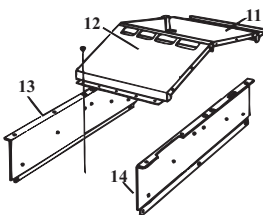

CODES 15-33 Exterior Furnace Cabinet Parts for Outdoor Model Series RX (also the furnace section of Model Series RXE, RXJ, REB, and REBJ)

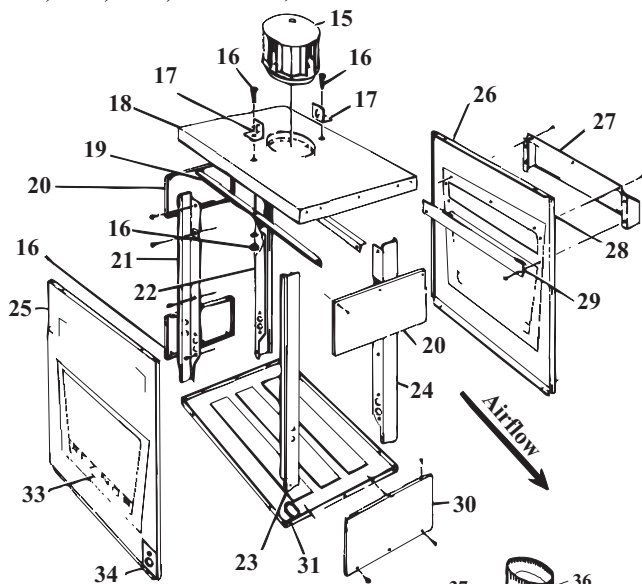

CODES 34-37 Flue Collection Parts for Outdoor Model Series RX (also the furnace section of Model Series RXE, RXJ, REB, and REBJ)

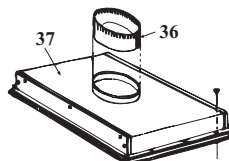

CODE 15A - Vent Cap Extension for Model Series RX

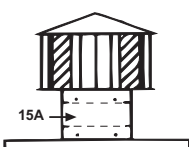

Model	Furnace		Extension	
	Sizes	Series	Height	P/N
RX, HRX	300,	Prior to Series 8 & Series 8	12"	20524
	350,			
	400			
CRX, HCRX	350	Prior to Series 8 & Series 8	12"	20524
	400			
	400			
	400	Series 8	12"	20524

Code	Description	
1	Flue Collar Assembly	X Series
		CX Series 6
2	Draft Hood & Top Assy w/ Flue Collar	X Series
		CX Series 6
3	Flue Collar Support	
4	Hanger connector	
5	Right Front & Left Rear Corner Legs	Prior to Series 6
5A	Left Rear Corner leg	Series 6 & 8
5B	Right Rear Corner Leg	Series 6 & 8
6	Left Front & Right Rear Corner Legs	
7	Bottom Front & Rear Panel	
8	Casing Side Panel Doors	
9	Heater Bottom Pan	Aluminized
		409 Stainless
10	Top Back	
11	Draft Hood Rear Baffle	Prior to Series 6
		Series 6 & 8
12	Draft Hood Front Baffle	Prior to Series 6
		Series 6 & 8
13	Draft Hood Right Side	Prior to Series 6
		Series 6 & 8
14	Draft Hood Left Side	Prior to Series 6
		Series 6 & 8
15	Vent Cap	
15A	Vent Cap Extension - See Table below	
16	Hex Head Bolt 7/16 x 1	
17	Lift Eye	
18	Casing Top Assembly (includes insulation)	
		Casing Top Assembly - Series 5W & 6W (wide cabinet)
19	Hanger Angle	
20	Top Front & Back	
21	Left Rear Corner Leg	
		Left Rear Corner Leg - Series 5W & 6W (wide cabinet)
22	Right Rear Corner Leg	
		Right Rear Corner Leg - Series 5W & 6W (wide cabinet)
23	Left Front Corner Leg	
		Left Front Corner Leg - Series 5W & 6W (wide cabinet)
24	Right Front Corner Leg	
		Right Front Corner Leg - Series 5W & 6W (wide cabinet)
25	Left Casing Assembly with Combustion Air Screen Assembly	
26	Right Casing Assembly with Combustion Air Screen Assembly	
27	Combustion Air Inlet Shield	
28	Combustion Air Inlet Screen	
29	Combustion Air Inlet Angle	
30	Bottom Front & Rear Panel	
31	Heater Bottom Pan	Aluminized
		409 Stainless
		Heater Bottom Pan - Series 5W & 6W (wide cabinet)
		Aluminized
		409 Stainless
32	Corner Panel	
33	Reznor Name Plate	
34	Flue Restrictor - See Type & Size on page 6.	RX, HRX prior to Series 6
		RX, HRX Series 6
		RX, HRX Series 8
		CRX, HCRX - All
35	"Z" Baffle used w/ optional extended stack (Option ZZ) - See Type & Size on page 6.	RX, HRX prior to Series 6
		RX, HRX Series 6
		RX, HRX Series 8
		CRX, HCRX - All
36	Flue Collar	Prior to Series 6
		Series 6 & 8
37	Flue Collection Box w/ Flue Collar	Prior to Series 6
		RX Series 6 & 8
		CRX Series 6 & 8
38	Louver Frame w/ Horizontal Louvers	Apply to Model XE
39	Horizontal Louver Only	See the illustration
40	Vertical Louver Only	on page 6.
41	Support Feet (not illustrated)	Apply to Model X

Code	75	100	125	150	175	200	225	250	300	D-300	350	400
1	55197	9918	9882	9842	9842	12727	12727	86047	86047	86047	86049	86049
	55197	9918	9882	--	9842	--	12727	9803	86047	--	86047	86049
2	55196	20830	20831	20832	20832	20833	20833	86059	86059	86063	86060	86061
	55196	20830	20831	20831	20832	--	20833	85533	86059	--	86062	86061
3	9848	9848	9848	9848	9848	9691	9691	9691	9691	9691	9691	9691
4	9557(2)	9557(2)	9557(2)	9557(2)	9557(2)	9557(2)	9557(2)	9557(2)	9557(2)	9557(2)	9557(2)	9557(2)
5	10309(2)	10309(2)	10309(2)	10309(2)	10309(2)	10311(2)	10311(2)	10311(2)	10311(2)	10311(2)	10311(2)	10311(2)
5A	11004	11004	11004	11004	11004	11006	11006	11006	11006	11006	11006	11006
5B	10309	10309	10309	10309	10309	10311	10311	10311	10311	10311	10311	10311
6	10310(2)	10310(2)	10310(2)	10310(2)	10310(2)	10312(2)	10312(2)	10312(2)	10312(2)	10312(2)	10312(2)	10312(2)
7	67693(2)	9926(2)	9889(2)	9850(2)	9850(2)	9810(2)	9810(2)	9771(2)	9771(2)	9542(2)	9735(2)	9542(2)
8	11819(2)	11819(2)	11819(2)	11819(2)	11819(2)	11849(2)	11849(2)	11849(2)	11849(2)	11849(2)	11849(2)	11849(2)
9	15244	15244	15248	14618	14618	14624	14624	14625	14625	14632	15249	14632
	15978	15978	26167	15979	15979	15980	15980	15981	15981	15982	26168	15982
10	9916	9916	9880	9840	9840	9801	9801	9762	9762	9684	9729	9684
11	67676	67676	67678	67679	67679	67680	67680	67682	67682	--	67684	67686
	85778	85778	85782	85786	85786	85790	85790	85793	85793	85799	85796	85799
12	85802	85803	85806	85804	85805	67699	17486	67701	17507	67044	17525	17540
	85802	85803	85536	85804	85805	67699	17486	67701	17507	67044	17525	17540
13	17374	17374	17374	17374	17374	17484	17484	17484	17484	--	17484	17484
	85807	85807	85807	85807	85807	17484	17484	17484	17484	17484	17484	17484
14	17373	17373	17373	17373	17373	17483	17483	17483	17483	--	17483	17483
	85808	85808	85808	85808	85808	17483	17483	17483	17483	17483	17483	17483
15	110053-6"	110053-6"	61857-8"	61857-8"	61857-8"	61866-10"	61866-10"	61866-10"	RX-61875-12" CRX-61866-10"	61875-12"	61875-12"	61875-12"
15A												
16	16251(2)	16251(2)	16251(2)	16251(2)	16251(2)	16251(2)	16251(2)	16251(2)	16251(2)	16251(2)	16251(2)	16251(2)
17	11026(2)	11026(2)	11026(2)	11026(2)	11026(2)	11026(2)	11026(2)	11026(2)	11026(2)	11026(2)	11026(2)	11026(2)
18	10847	10847	10866	10873	10873	10881	10881	10890	RX-11107 CRX-103656	10904	10897	10904
	90838	90838	--	--	--	--	--	--	--	--	--	--
19	11012(2)	11012(2)	11012(2)	11012(2)	11012(2)	11012(2)	11012(2)	11012(2)	11012(2)	11012(2)	11012(2)	11012(2)
20	67708(2)	67708(2)	10869(2)	10869(2)	10869(2)	10886(2)	10886(2)	10892(2)	10892(2)	10906(2)	10900(2)	10906(2)
21	11004	11004	11004	11004	11004	11006	11006	11006	11006	11006	11006	11006
	90842	90842	--	--	--	--	--	--	--	--	--	--
22	10310	10310	10310	10310	10310	10312	10312	10312	10312	10312	10312	10312
	90840	90840	--	--	--	--	--	--	0	--	--	--
23	11003	11003	11003	11003	11003	11005	11005	11005	11005	11005	11005	11005
	90843	90843	--	--	--	--	--	--	--	--	--	--
24	10309	10309	10309	10309	10309	10311	10311	10311	10311	10311	10311	10311
	90841	90841	--	--	--	--	--	--	--	--	--	--
25	67710	67710	55291	14613	14613	14621	14621	14621	14621	14621	14621	14621
26	67713	67713	55292	17254	17254	11052	11052	11052	11052	11052	11052	11052
27	10851	10851	10851	10851	10851	10851	10851	10851	10851	10851	10851	10851
28	--	--	--	148396	148396	148396	148396	148396	148396	148396	148396	148396
29	12649	12649	12649	10850	10850	10850	10850	10850	10850	10850	10850	10850
30	67693(2)	67693(2)	9889(2)	9850(2)	9850(2)	9810(2)	9810(2)	9771(2)	9771(2)	9542(2)	9735(2)	9542(2)
31	15244	15244	15248	14618	14618	14624	14624	14625	14625	14632	15249	14632
	--	--	15978	15979	15979	15980	15980	15981	15981	15982	26168	15982
	15248	15248	--	--	--	--	--	--	--	--	--	--
	15978	15978	--	--	--	--	--	--	--	--	--	--
32	15029	15029	15029	15029	15029	15029	15029	15029	15029	15029	15029	15029
33	P/N 121264 (replaces 9538)											
34	55290	--	--	--	--	13145	13148	--	14935	--	--	--
	86435	--	86440	86444	86446	86454	86456	86444	86465	--	15599	86465
	136738	136739	86440	136740	136741	86493	136742	86493	86454	--	--	--
	86492	86479	89205	--	89206	--	89208	89209	89210	--	86488	86490
35	15580	45476	15584	15588	15590	15593	15596	15599	15601	--	15603	15611
	86491	86492	15584	86485	86493	86488	14935	15599	15601	15601	86494	86495
	136743	136744	136745	136746	86493	89212	15596	86454	136747	--	86495	86495
	86496	89211	15584	--	86485	--	86488	89212	86497	--	86498	89213
36	12012	12012	12013	12013	12013	12014	12014	12014	RX-12015 CRX-12014	--	12015	12015
	12011	12011	86474	86474	86474	12014	12014	12014	RX-12015 CRX-12014	12015	12015	12015
	55289	10854	10862	10870	10870	10876	19832	10887	11104	--	10893	10901
37	86430	86436	86437	86441	86445	86447	86455	86457	86463	87148	86466	86470
	86476	86478	86480	--	86482	--	89207	86484	86486	--	86487	86489
38	39711	39711	10018	10016	10016	10014	10014	10012	10012	10001	10010	10001
39	9923(5)	9923(5)	9887(5)	9847(5)	9847(5)	9808(5)	9808(5)	9679(10)	9679(10)	9553(10)	9733(10)	9553(10)
40	9554(3)	9554(3)	9554(4)	9554(6)	9554(6)	9554(8)	9554(8)	9554(10)	9554(10)	9554(14)	9554(12)	9554(14)
41	10680(4)	10680(4)	10680(4)	10680(4)	10680(4)	10680(4)	10680(4)	10680(4)	10680(4)	10680(4)	10680(4)	10680(4)

Codes 34 and 35 - Flue Restrictors for Model RX, pages 4 and 5



"D" Type



"S" Type

P/N	Type	Size	P/N	Type	Size	P/N	Type	Size
13145	S	4-1/2 x 11	86446	S	2-3/4 x 7-1/2	89206	S	3-5/8 x 7-1/2
13148	S	2-1/2 x 11	86454	D	7 x 7	89208	D	6-7/8 x 6-7/8
14935	S	7-3/4 x 7-3/4	86456	D	6-5/8 x 6-5/8	89209	D	6-3/8 x 6-3/8
15580	S	4-5/8 x 4-5/8	86465	S	8-1/4 x 8-1/4	89210	S	3 x 7-1/2
15584	S	6-7/16 x 6-7/16	86479	S	1-3/4 x 5-3/4	89211	S	4-3/4 x 4-7/16
15588	D	6-1/8 x 6-1/8	86485	D	6-1/4 x 6-1/4	89212	D	7-3/4 x 7-3/4
15590	D	5-7/8 x 5-7/8	86488	S	8 x 8	89213	S	8-5/8 x 8-5/8
15593	D	7-13/16 x 7-13/16	86490	S	4-7/8 x 11-3/4	136738	D	3-3/8 x 3-3/8
15596	D	7-5/8 x 7-5/8	86491	S	4-7/16 x 4-7/16	136740	D	5-1/8 x 5-1/8
15599	D	7-1/2 x 7-1/2	86492	S	4-1/4 x 4-1/4	136741	D	4-13/16 x 4-13/16
15601	S	9-1/4 x 9-1/4	86493	D	6 x 6	136742	D	4-1/2 x 4-1/2
15603	D	8-7/8 x 8-7/8	86494	S	8-7/8 x 8-7/8	136743	D	4-5/8 x 4-5/8
15611	D	8-1/2 x 8-1/2	86495	S	8-1/2 x 8-1/2	136744	D	4-1/4 x 4-1/4
55290	S	3 x 5-3/4	86496	S	4-3/4 x 4-3/4	136745	D	6-3/8 x 6-3/8
86435	S	4-1/8 x 4-1/8	86497	D	7-3/8 x 7-3/8	136746	D	6-1/8 x 6-1/8
86440	D	5-5/8 x 5-5/8	86498	S	9 x 9	136747	D	9-1/8 x 9-1/8
86444	S	3-1/2 x 7-1/2	89205	D	5-3/4 x 5-3/4			

CODES 38, 39 & 40 - Optional Louvers for Model Series XE (P/N's are on pages 4 and 5)

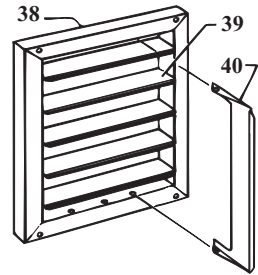

CODES 45-60 Exterior Furnace Cabinet Parts for Outdoor Model Series RPV (also the furnace section of Model Series RPVE, RPBE, and RPVJ)

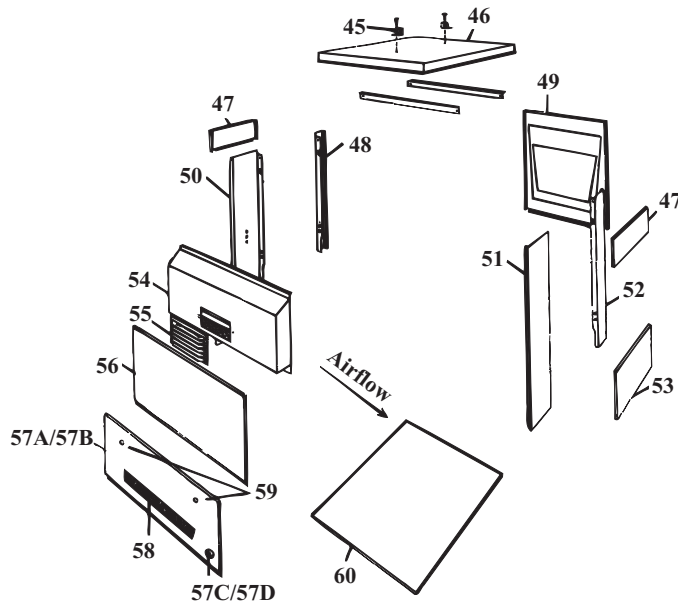

CODES 61-78 Flue Collection Box and Venter components for Model Series RPV 3, 5, 6 and 8

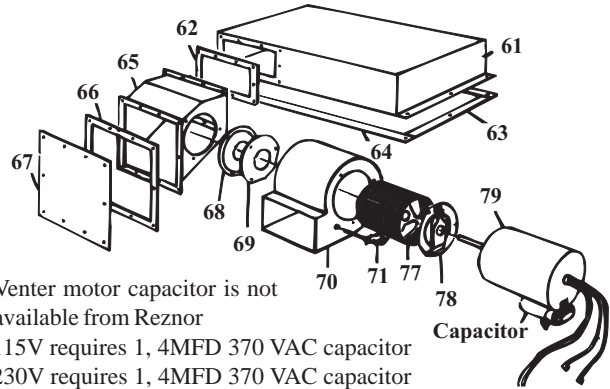

Venter motor capacitor is not available from Reznor
 115V requires 1, 4MFD 370 VAC capacitor
 230V requires 1, 4MFD 370 VAC capacitor
 460V requires 2, 2MFD 370 VAC capacitors

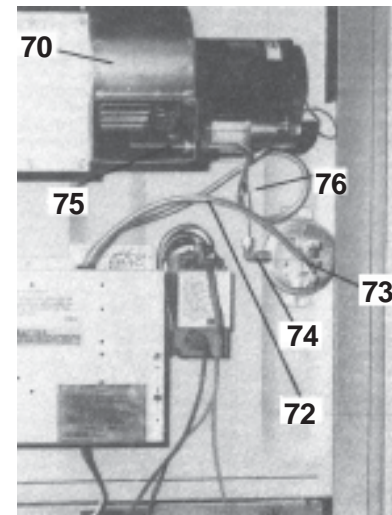

Code 80 - Pressure Switch Kit, P/N 93033, for RPV Series 3 and 5 (to replace sail switch with pressure switch)

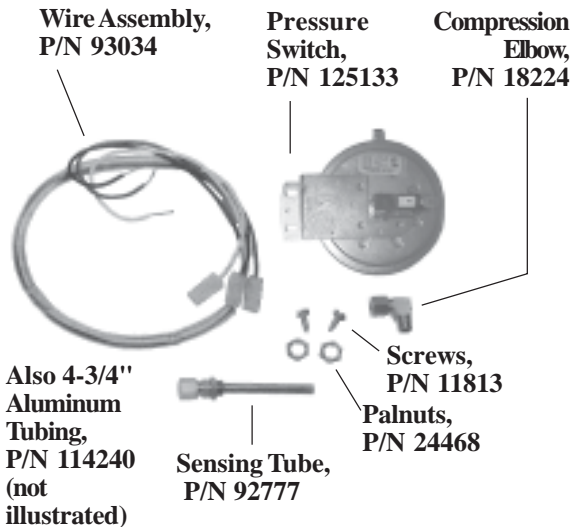

Code 81 - Vertical Vent Kit, P/N 45021 (Same as Option CC3)

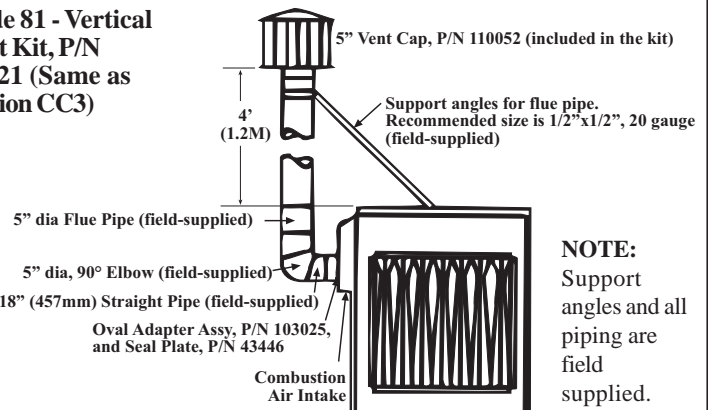

NOTE: Support angles and all piping are field supplied.

Code	Description	125	150	175	200	225	250	300	350	400	
45A	Lift Eye	11026(2)	11026(2)	11026(2)	11026(2)	11026(2)	11026(2)	11026(2)	11026(2)	11026(2)	
45B	Hanger Angle	31904(2)	31904(2)	31904(2)	11012(2)	11012(2)	11012(2)	11012(2)	11012(2)	11012(2)	
46	Casing Top Assembly (includes insulation)	43936	43939	43939	43942	43942	43945	43945	43948	43951	
47	Top Front and Back	64667(2)	64669(2)	64669(2)	9810(2)	9810(2)	9771(2)	9771(2)	9735(2)	9542(2)	
48	Right Rear Heater Leg	10310	10310	10310	10312	10312	10312	10312	10312	10312	
49	Right Casing Side Panel	30145	30145	30145	14114	14114	14114	14114	14114	14114	
50	Left Rear Corner Leg - Control Side	68426	68426	68426	68428	68428	68428	68428	68428	68428	
51	Left Front Corner Leg - Control Side	68425	68425	68425	68427	68427	68427	68427	68427	68427	
52	Right Front corner Leg	10309	10309	10309	10311	10311	10311	10311	10311	10311	
53	Bottom Front & Rear Panel	Series 3	9889(2)	9850(2)	9850(2)	9810(2)	9810(2)	9771(2)	9771(2)	9735(2)	9542(2)
		RPV and CRPV 5, 6 and 8	64662(2)	64664(2)	64664(2)	9810(2)	9810(2)	9771(2)	9771(2)	9735(2)	9542(2)
54	Venter Shroud Assembly	43920	43920	43920	43921	43921	43921	43921	43921	43921	
55	Exhaust Grill	41992	41992	41992	41992	41992	41992	41992	41992	41992	
56	Access Panel	43954	43954	43954	43954	43954	43954	43954	43954	43954	
57	Bottom Left Side Panel	1/2" Gas Pipe	123999	123999	123999	123999	123999	123999	123999	123999	
		3/4" Gas Pipe	--	--	--	--	--	--	43429	43429	43429
57A	Gas Pipe Vinyl Grommet	1/2" Gas Pipe	102607	102607	102607	102607	102607	102607	102607	102607	
		3/4" Gas Pipe	--	--	--	--	--	--	15021	15021	15021
58	Reznor Name Plate	P/N 121264 (replaces 9538)									
59A	Lighter Cole Cover	RPV & CRPV 5, 6 & 8	10756(2)	10756(2)	10756(2)	10756(2)	10756(2)	10756(2)	10756(2)	10756(2)	
59B	Sight Hole cover	RPV & CRPV 5, 6 & 8	88688(2)	88688(2)	88688(2)	88688(2)	88688(2)	88688(2)	88688(2)	88688(2)	
60	Heater Bottom Pan	Aluminized	43432	43433	43433	43434	43434	43435	43435	43436	43437
		409 Stainless	48111	48112	48112	48113	48113	48114	48114	48115	48116
61	Flue Collection Box Assembly	RPV, HRPV prior to Series 8	43535	43536	43536	43537	43537	43538	43538	43539	43540
		RPV, HRPV Series 8	88353	88357	88357	136748	136748	88359	88359	92798	88348
		CRPV, HCRPV - All (no Series 8)	43535	43536	43536	43537	43537	43538	43538	43539	43540
62	Flue Duct Gasket	31900	31900	31900	31900	31900	31900	31900	31900	31900	
63	Side Gasket Strip	62933(2)	62933(2)	62933(2)	62933(2)	62933(2)	62933(2)	62933(2)	62933(2)	62933(2)	
64	Front and Rear Gasket Strips	62922(2)	62922(2)	62924(2)	62926(2)	62926(2)	62928(2)	62928(2)	62928(2)	62928(2)	
65	Flue Duct Assembly	41991	41991	41991	41991	41991	41991	41991	41991	41991	
66	Cover Plate Gasket	41996	41996	41996	41996	41996	41996	41996	41996	41996	
67	Flue Duct Cover Plate	41995	41995	41995	41995	41995	41995	41995	41995	41995	
68	Venter Gasket	44695	44695	44695	44695	44695	44695	44695	44695	44695	
69	Venter Restrictor	Models RPV, HRPV	43254	43255	43256	43257	43258	43259	43260	43261	62594
		Models CRPV, HCRPV	88506	--	68382	--	--	68386	88507	88507	88508
70	Venter Housing	RPV & CRPV 3 & 5	67716	67716	67716	67716	67716	67716	67716	67716	
		RPV 6 & 8 and CRPV 6	92778	92778	92778	92778	92778	92778	92778	92778	92792
71	Flow Switch Series 3 & 5 only - Do not order for units with Serial No. Date Code after ALJ (October 1986)	43847	43847	43847	43847	43847	43847	43847	43847	43847	
72	Wire Assembly	RPV & CRPV 6 & 8	93034	93034	93034	93034	93034	93034	93034	93034	
73	Pressure Switch (for RPV Series 3 and 5; see Code 80)	RPV & CRPV 6 & 8	125133 (replaces 68266) - see page 21, Code 304 before selecting								
		for High Altitude (above 4000 ft)	125134 (replaces 113234) - see page 21, Code 304 before selecting								
74	Compression Elbow	RPV 6 & 8 and CRPV 6	18224	18224	18224	18224	18224	18224	18224	18224	
75	Sensing Tube	RPV 6 & 8 and CRPV 6	133117 (replaces 92777)								
76	Aluminum Tubing, 1/4 x 18"	RPV 6 & 8 and CRPV 6	10349	10349	10349	10349	10349	10349	10349	10349	
77	Venter Wheel		43425	43425	43425	43425	43425	43425	43425	43814	
78*	Venter Motor Mounting Plate		131445	131445	131445	131445	131445	131445	131445	131448	
79*	Venter Motor (all motors include capacitor, P/N 103181)	(units mfgd beginning 7/94) 115V	131410	131410	131410	131410	131410	131410	131410	131410	
		(units mfgd beginning 7/94) 208V	131415	131415	131415	131415	131415	131415	131415	131415	
		(units mfgd beginning 7/94) 230V	131415	131415	131415	131415	131415	131415	131415	131415	
		(units mfgd beginning 3/94) 460V	125673	125673	125673	125673	125673	125673	125673	125673	
80	Pressure Switch Kit (sea level to 4000 ft) for RPV 3 & 5 (illustrated on page 6)	93033	93033	93033	93033	93033	93033	93033	93033	93033	
81	Vertical Vent Kit, Same as Option CC3	45021	45021	45021	45021	45021	45021	45021	45021	45021	

* Codes 78 and 79, replacement venter motor and venter motor mounting plate, apply to units manufactured after the dates shown in the table below. For units manufactured prior to the dates listed, replacing a venter motor must be done with a venter motor replacement kit that includes new motor mounting plates.

Venter Motor Replacement Kits

Voltage	P/N	Applies to Heaters Manufactured
115V	132377	prior to 7/94 (Serial No. Code ATG)
208V	132378	prior to 7/94 (Serial No. Code ATG)
230V	132378	prior to 7/94 (Serial No. Code ATG)
460V	132379	prior to 3/94 (Serial No. Code ATC)
575V	132377	prior to 7/94 (Serial No. Code ATG)

Parts for RPV Models prior to Series 3 and Series 5 prior to 1976 are not available except for replacement venters. For replacement venter motors for these older models, it is necessary to order one of the below listed venters. To install, remove the venter blower housing and discard.

for RPV 50-175

115V, P/N **29992** (Model LV301 venter)

208V, P/N **30229** (Model LV301B venter)

230V, P/N **30231** (Model LV301H venter)

Venter Sail Switch for above, P/N **7299** (2-wire)

for RPV 200-400

115V, P/N **29994** (Model LV401 venter)

208V, P/N **30233** (Model LV401B venter)

230V, P/N **30235** (Model LV401H venter)

Venter Sail Switch for above, P/N **13925** (2-wire)

Burner Rack and Components

Burner Rack - All Models

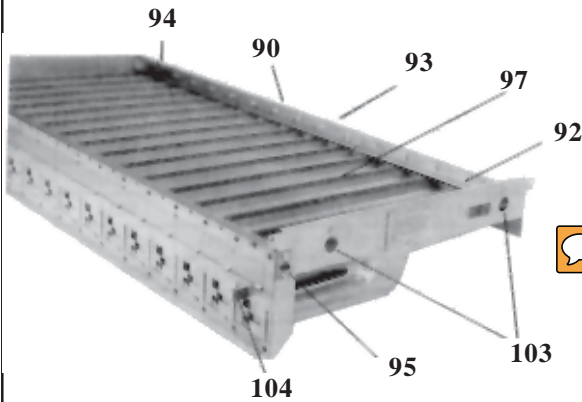

Carryover Tube and Drip Shield

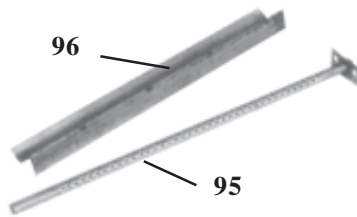

Manifold - Code 98

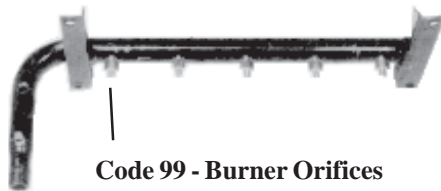

Carryover Regulator Assembly for Propane Gas - Code 101

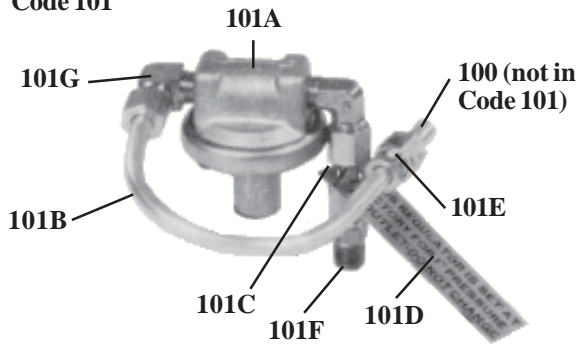

Carryover Tubing - Natural Gas

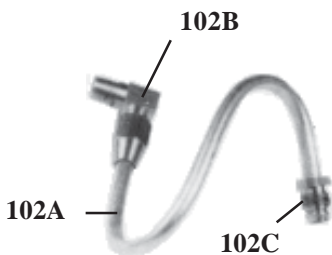

Air Shutter Hardware

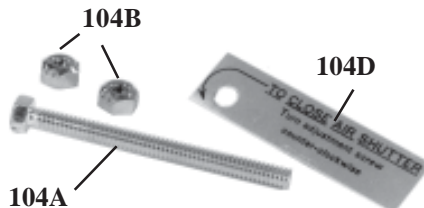

Code 105 - P/N 3284, Pilot Shutoff Valve



Code	Description		
90	Burner Rack with Carryovers and Air Shutters	Aluminized	
		Stainless Steel	
91	Flash Carry over (one piece)		
92	Flash Carry over Right Section		
93	Flash Carry over Center Section		
94	Flash Carry over Left Section		
95	Carryover Lighter Tube (Tube only)	All RX and RPV; X propane;	
96	Carryover Lighter Tube Drip Shield	X natural prior to Series 8	
97	Main Burner only	Aluminized	
		Stainless Steel	
98	Manifold (less orifices)		
99	Burner	(H)X, RX Natural Gas	All Series
	Orifice	(H)CX, CRX Natural Gas	All Series
	Drill Size	(H)RPV Natural Gas	All Series
	See	(H)CRPV Natural Gas	All Series (no Series 8)
	bottom of the page for P/N's.	(H)X, RX Propane Gas	All Series
		(H)CX, CRX Propane Gas	All Series
		(H)RPV Propane Gas	All Series
		(H)CRPV Propane Gas	All Series (no Series 8)
		(H)CRPV Propane Gas	All Series (no Series 8)
100	Carryover Orifice	(H)X Natural Gas	Prior to Series 8
		(H)RX Natural Gas	All Series
	Drill Size	(H)CX Natural Gas	All Series
		(H)CRX Natural Gas	All Series (no Series 8)
	See bottom of the page for P/N's.	(H)RPV Natural Gas	All Series
		(H)CRPV Natural Gas	All Series (no Series 8)
		(H)X Propane Gas	All Series
		(H)RX Propane Gas	All Series
		(H)CX Propane Gas	All Series (no Series 8)
(H)CRX Propane Gas	All Series		
	(H)RPV Propane Gas	Prior to Series 8	
	(H)CRPV Propane Gas	All Series (no Series 8)	
101	Carryover Regulator Assembly (includes Codes 133A-G)		
101A	Carryover Regulator, Maxitrol RV-12, Propane Gas		
101B	Carryover Regulator Tubing 1/4" x 5-1/2"		
101C	Carryover Regulator Tubing 1/4" x 1-1/4"		
101D	Carryover Regulator Tag		
101E	Carryover Regulator Fitting (Compression Fitting)		
101F	Carryover Regulator Fitting, Regulator to Manifold		
101G	Carryover Regulator Fitting, 90° Brass Elbow		
102A	Carryover Tubing, Natural Gas		
102B	Brass Elbow		
102C	Compression Fitting		
103	Burner Rack Isinglass		
104A	Air Shutter Adjustment Screw, 1/4-20 x 2-1/2" long		
104B	Air Shutter Screw Nut, 1/4" -20		
104C	Air Shutter Slide Tinnerman Nut, 1/4"-20 (not illustrated)		
104D	Air Shutter Adjustment Instruction Tag		
135	Pilot Gas Valve, P/N 3284		
136	Manual Gas Valve, 1/2", P/N 17019		
	Manual Gas Valve, 3/4", P/N 1105		
	Manual Gas Valve, 1", P/N 110755		

Code	75	100	125	150	175	200	225	250	300	D300	350	400
90	65971	65972	65973	65974	65974	65975	65975	65976	65976	65978	65977	65978
	65979	65980	65981	65982	65982	65983	65983	65984	65984	65986	65985	65986
91	63128	63128	63131	63131	63138	--	--	--	--	--	--	--
92	--	--	--	--	--	63148	63148	63141	63141	63152	63148	63152
93	--	--	--	--	--	--	--	63156	63156	68071	68071	68071
94						63144	63144	63144	63144	63144	63144	63144
95	9899	9899	9859	9821	9821	9783	9783	9747	9747	9520	9711	9520
96	15015	15015	15014	15013	15013	15012	15012	15011	15011	14957	15010	14957
97	85218(4)	85218(4)	85218(5)	85218(7)	85218(7)	85218(9)	85218(9)	85218(12)	85218(12)	85218(16)	85218(14)	85218(16)
	87954(4)	87954(4)	87954(5)	87954(7)	87954(7)	87954(9)	87954(9)	87954(12)	87954(12)	87954(16)	87954(14)	87954(16)
98	86338	86338	86339	86340	86340	86342	86342	86343	86343	86345	86344	86345
99	45	41	41	43	41	43	41	44	41	45	41	41
	45	43	43	--	43	--	43	45	43		43	43
	--	--	42	44	42	43	42	44	42	42	42	42
	--	--	43	--	43	--	43	45	43		43	43
	1.20mm	1.45mm	1.45mm	55	1.45mm	55	1.45mm	55	1.45mm	1.20mm	1.45mm	1.45mm
	1.20mm	55	55	--	55	55	55	1.20mm	55	55	55	55
	--	--	1.45mm	55	1.45mm	55	1.45mm	55	1.45mm	1.45mm	1.50mm	1.45mm
	--	--	55		55	55	55	1.20mm	55	55	--	55
100	70	70	70	65	65	59	59	59	59	--	54	54
	70	70	70	65	65	59	59	59	59	--	54	54
	70	70	70	65	65	59	59	59	59	--	54	54
	70	70	70	65	65	59	59	59	59	--	54	54
	--	--	65	65	65	65	65	59	59	--	54	52
	--	--	66	66	66	66	65	59	59	--	54	52
	70	70	70	65	65	65	65	59	56	56	56	56
	70	70	70	65	65	65	65	59	56	56	56	56
	70	70	70	65	65	65	65	59	56	56	56	56
	70	70	70	65	65	65	65	59	56	56	56	56
	--	--	70	65	65	65	65	59	59	59	57	56
			70	65	65	65	65	59	59	59	57	56
101	100712	100712	100712	100712	100712	100712	100712	100712	100712	100712	100712	100712
101A	11294	11294	11294	11294	11294	11294	11294	11294	11294	11294	11294	11294
101B	9681	9681	9681	9681	9681	9681	9681	9681	9681	9681	9681	9681
101C	11892	11892	11892	11892	11892	11892	11892	11892	11892	11892	11892	11892
101D	11935	11935	11935	11935	11935	11935	11935	11935	11935	11935	11935	11935
101E	9664	9664	9664	9664	9664	9664	9664	9664	9664	9664	9664	9664
101F	1436	1436	1436	1436	1436	1436	1436	1436	1436	1436	1436	1436
101G	18224(2)	18224(2)	18224(2)	18224(2)	18224(2)	18224(2)	18224(2)	18224(2)	18224(2)	18224(2)	18224(2)	18224(2)
102A	93389	93389	93389	93389	93389	93389	93389	93389	93389	93389	93389	93389
102B	93388	93388	93388	93388	93388	93388	93388	93388	93388	93388	93388	93388
102C	9664	9664	9664	9664	9664	9664	9664	9664	9664	9664	9664	9664
103	10756(2)	10756(2)	10756(2)	10756(2)	10756(2)	10756(2)	10756(2)	10756(2)	10756(2)	10756(2)	10756(2)	10756(2)
104A	10653	10653	10653	10653	10653	10653	10653	10653	10653	10653	10653	10653
104B	10650(2)	10650(2)	10650(2)	10650(2)	10650(2)	10650(2)	10650(2)	10650(2)	10650(2)	10650(2)	10650(2)	10650(2)
104C	10651	10651	10651	10651	10651	10651	10651	10651	10651	10651	10651	10651
104D	11934	11934	11934	11934	11934	11934	11934	11934	11934	11934	11934	11934

**Code 106 -
Shutoff Valves**

P/N 17019,
1/2" Shutoff Valve
(with union, P/N 15971)

P/N 1105, 3/4" Shutoff
Valve (with union P/N 15972)

P/N 110755, 1" Shutoff

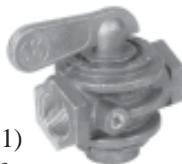

Reference: For replacement electric gas valve, see
Form RGM 714.

Main Burner Orifice Drill Size to P/N - see Code 99

Size	41	42	43	44	45	55	1.20MM	1.45MM	1.50MM
P/N	11792	84437	11828	11833	38678	11830	63003	61652	93410

Carryover Orifice Drill Size to P/N - see Code 100

Size	70	65	59	57	56	54
P/N	9870	9680	10370	38274	9791	9792

Heat Exchanger and Components

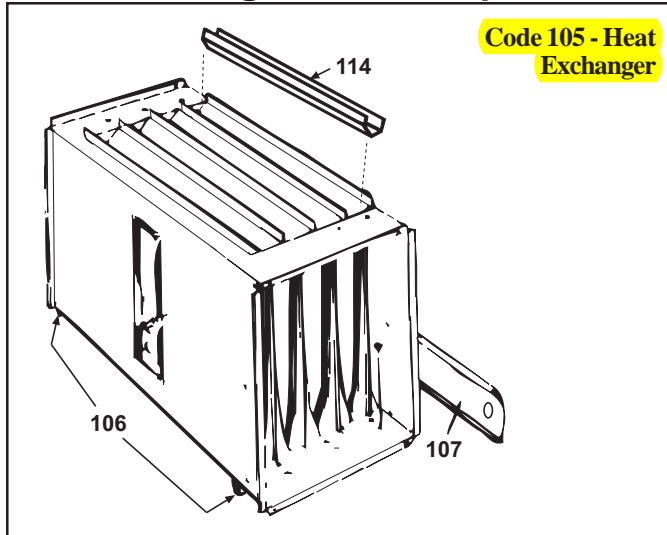

Heat Exchanger Directional Air Baffles

Models X, CX, RX, CRX, RPV, CRPV Series 5, 6, 7 and 8 and packaged systems with these duct furnaces as components are equipped with a heat exchanger directional air baffle assembly as shown in the illustration on the left below.

When replacing a heat exchanger, check to see if the baffle assembly can be salvaged. If the baffle assembly cannot be salvaged, it will be necessary to order the parts (Codes 108-113) in the quantities listed and assemble and install replacement baffles. (These parts must be ordered separately and installed in the field. Baffles cannot be factory installed.)

Models HX, HCX, HRX, HCRX, HRPV, HCRPV Series 5, 6, 7, and 8 and packaged systems with "H" or "HC" suffix are equipped with only a rear top baffle support (Code 111) and a rear top baffle (Code 112) as shown in the lower left illustration. If these parts cannot be salvaged, order and install replacements.

These parts must be ordered separately and installed in the field.



Code	Description	Qty	75, 100	125	150, 175	200, 225	250, 300	350	D300, 400	
105	Heat Exchanger	X, CX - Aluminized Steel	1	9895	9855	9817	9779	9743	9707	9514
		X, CX - 409 Stainless Steel	1	19429	19430	19431	19432	19433	19434	19435
		X, CX - 321 Stainless Steel	1	19438	19439	19440	19441	19442	19443	19444
		RX, CRX - Aluminized Steel	1	44301	44304	44307	44310	44313	44316	44319
		RX, CRX - 409 Stainless Steel	1	44302	44305	44308	44311	44314	44317	44320
		RX, CRX - 321 Stainless Steel	1	44303	44306	44309	44312	44315	44318	44321
		RPV, CRPV - Aluminized Steel	1	--	44304	44307	44310	44313	44316	44319
		RPV, CRPV - 409 Stainless Steel	1	--	44305	44308	44311	44314	44317	44320
		RPV, CRPV - 321 Stainless Steel	1	--	44306	44309	44312	44315	44318	44321
106	Burner Rack Slide Rail	All Models Series 5, 6, 7, & 8	2	9897	9857	9819	9781	9745	9709	9517
107	Burner Rack Back Brace	All Models Series 5, 6, 7, & 8	1	9525	9525	9525	9525	9525	9525	9525
108	Bracket for Bottom Baffle Support	X, RX, RPV Series 5, 6, 7, and 8	1	55101	55101	55101	55101	55101	55101	55101
			➤	(2)	(2)	(2)	(2)	(4)	(4)	(4)
109	Finger Baffle	X, RX, RPV Series 5, 6, 7, and 8	➤	45399	45399	45399	45399	45399	45399	45399
			➤	(3)	(3)	(6)	(8)	(11)	(13)	(15)
110	Bottom Baffle Support	X, RX, RPV Series 5, 6, 7, and 8	1	46478	46484	46489	46494	46499	46504	46509
111	Rear Top Baffle Support	All Models Series 5, 6, 7, & 8	1	55103	55104	55106	55108	55110	55112	55114
112	Rear Top Baffle	All Models Series 5, 6, 7, and 8	1	55228	55229	55231	55233	55235	55237	55239
		Series 5W and 6W	1	55228	55228	--	--	--	--	--
113	Side Finger Baffle	X, RX, RPV Series 5, 6, 7, and 8	2	55128	55128	55128	55128	55128	55128	55128
114	Heat Exchanger Tube Baffles ("V" Type Baffles)	Series 8 - All Models	➤	85727	85727	85727	85727	85727	85727	85727
			➤	(4)	(4)	(7)	(9)	(12)	(14)	(16)
		Prior to Series 8 - "C" Models Only	➤	85727	85727	85727	85727	85727	85727	85727
			➤	(4)	(4)	(7)	(9)	(12)	(14)	(16)

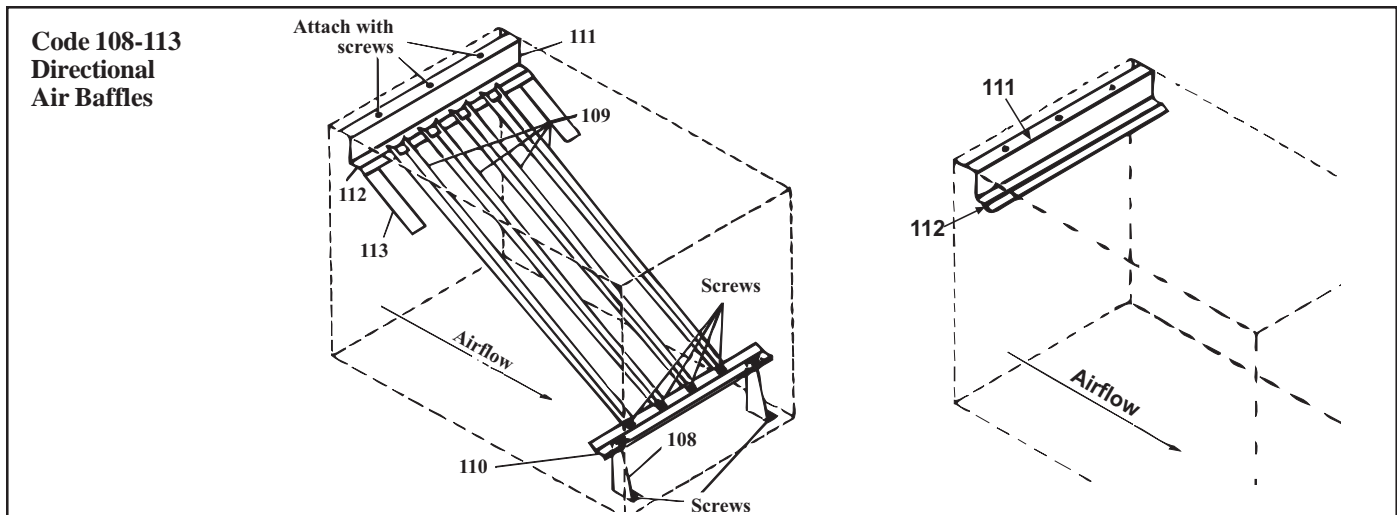

Adapter Backs for Blowers and Blowers

Code	Component Description	75, 100, 125	150, 175	200, 225	250, 300	350	400
115	Blower Adapter Back Assembly	193986	194054	194093	193988	194063	194064
116	Blower Adapter Top & Bottom	(2)53277	--	--	--	--	--
117	Blower Adapter Sides	(2)53278	--	--	--	--	--
118	Left Corner Support Filler	53279	--	--	--	--	--
119	Right Corner Support Filler	53280	--	--	--	--	--

Code	Component Description	75, 100, 125	150, 175, 200, 225	250, 300	350, 400
120	Blower including Housing, Wheel, Shaft and Bearings	1357	1360	--	--
121	Blower with motor bracket (includes housing and wheel only)	--	--	24230	24232
122	Blower Housing and Wheel only	--	--	24229	24231
123	Blower Motor Mounting Bracket	Less than 1-1/2 HP	44409	44410	44409
124	Blower Shaft	11302 3/4 x 22	11303 1 x 22	10120 1 x 39-1/4	10121 1 x 44-5/8
125	Blower Bearings	(2)	7310	10437	10437
126	Motor Adjustment Bracket Assembly		44411	44411	44411
126A	Hex Head Bolt 5/16 -18 x 4" for Code 226		14668	14668	14668
127	Hardware Bag		64940	64940	64940
128	Motor Mounting Plate	1-1/2 HP Motor and Larger	12578	12578	12578
129	Left Mounting Plate Support		12576	12576	12576
130	Right Mounting Plate Support		12577	12577	12577
131	Rod Bolt for Motor Mounting Plate Assembly		12489	12489	12489
132	Blower Key, P/N 19361				

Contactors and Starters - See pages 14 - 18.

Motors - See pages 14 - 18.

Drive Components - See page 19.

Blower for Sizes 75-225, A10-10AC 3/4"

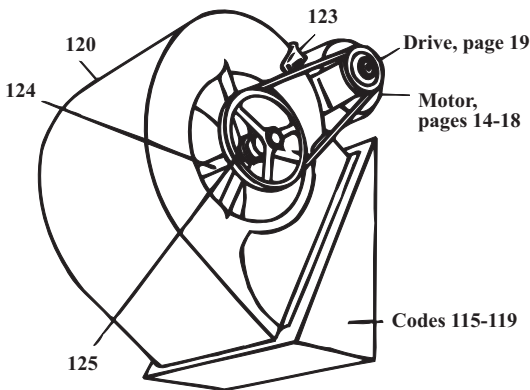

NOTE: Blower adapter backs for Sizes 50 through 100 manufactured prior to 1980 are no longer available.

Blowers for Sizes 250-300, 2A10-10A 1"

Blowers for Sizes 350-400, 2A12-12A 1"

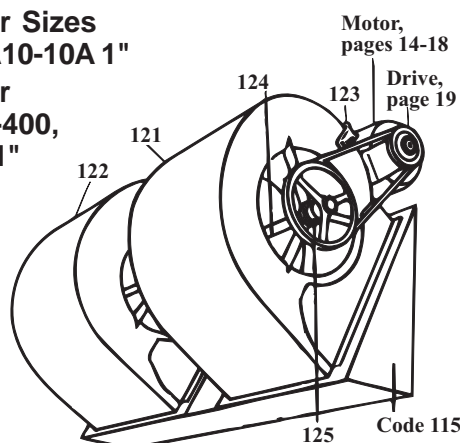

Code 123 - Motor Mounting Bracket

For motors less than 1-1/2HP (for larger motors, see Codes 128-131)

P/N 44409 for 14" plate, 10" wheel
P/N 44410 for 16" plate, 12" wheel



Code 126 - Motor Adjustment Bracket Assembly for Motors less than 1-1/2HP

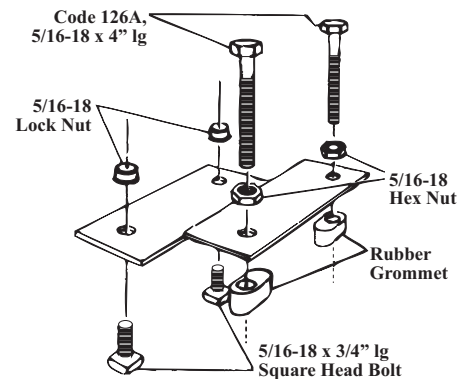

Code 127 - Replacement Hardware for Motor Adjustment Bracket Assembly, Code 126



Codes 128 - 132 Motor Mounting Plate for Motors 1-1/2 HP and larger

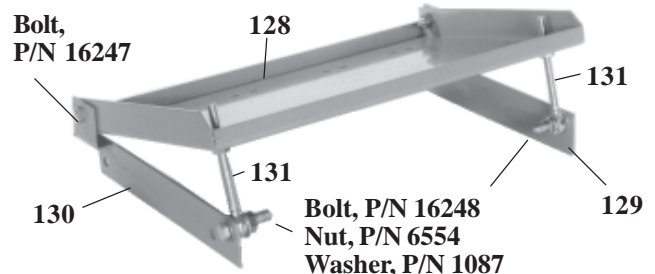

Blower Cabinets - Indoor Models

Code	Component Description	Cabinet	75, 100, 125	150, 175	200, 225	250, 300	350	400
149	Complete Blower Cabinet (less filter rack and filters)	Standard	12545	12546	12547	12548	12549	12550
		Optional	17046	17055	17063	17066	17120	17123
150	Hanger Assembly	All	9557	9557	9557	9557	9557	9557
151	Cabinet Top and Bottom	Standard	11522	11529	11197	11564	11574	11583
152	Cabinet Top	Optional	11825	11842	11767	11856	11862	11777
153	Blower Cabinet Door	Standard	51041	51041	51042	51042	51042	51042
		Optional	84221	84221	84222	84222	84222	84222
154	Blower Cabinet End panel	Optional	12075	12411	11540	12414	12029	11589
155	Hanger Support	All	10219	10219	10219	10219	10219	10219
156	Filter Support	All	19704	19710	19717	19723	19729	19736
157	Intermediate Filter Stops	All	19708	19715	19721	19727	19734	19742
158	Filter Stops or Blockoffs - Top/Btm	All	--	104086/104086	--	--	19733/19733	19740/19741
159	Cabinet Bottom Inlet Cap	Optional	12513	12514	11538	12515	12516	11587
160	Cabinet Bottom Left Side	Optional	11203	11203	11203	11203	11203	11203
161	Left Corner Support	All	11517	11517	11210	11210	11210	11210
162	Rear Bottom Section	Optional	11526	11533	11392	11571	11580	11393
163	Right Corner Leg	All	11519	11519	19982	19982	19982	19982
164	Cabinet Bottom Right Side	Optional	11204	11204	11204	11204	11204	11204
165	Insulation for End Panel	Optional	51053	51054	12327	12328	26103	12329
166	Insulation for Bottom Panel	Optional	11155	11162	11167	11176	11180	11184
167	Duct Connecting Angle	Standard	11523	11530	11536	11567	11576	11584
168	Hole Plug for Bottom Panel	Standard	82413	82413	82413	82413	82413	82413
169	Right Rear Corner Support	Standard	11518	11518	11211	11211	11211	11211
170	Filter Rack Assembly	All	24501	24503	24505	24507	24509	24511
171	Replacement Filters - apply to std and opt indoor cabinets	Fltr Qty and Size	(2) 20x20	(2) 20x25	(2) 16x20	(2) 20x20	(1) 20x20	(3) 16x25
					(2) 16x25	(2) 20x25	(3) 20x25	(2) 20x25
		1" disposable	16448	16446	16445	16448	16448	16447
					16447	16446	16446	16446
		2" disposable	104098	104100	104097	104098	104098	104099
					104099	104100	104100	104100
		1" permanent	101608	101610	101607	101608	101608	101609
					101609	101610	101610	101601
		2" permanent	101621	101623	101620	101621	101621	101622
					101622	101623	101623	101623
1" pleated	104106	104108	104105	104106	104106	104107		
			104107	104108	104108	104108		
2" pleated	104111	104113	104110	104111	104111	104112		
			104112	104113	104113	104113		

Standard Indoor Blower Cabinet - Basic Models XE, XJ

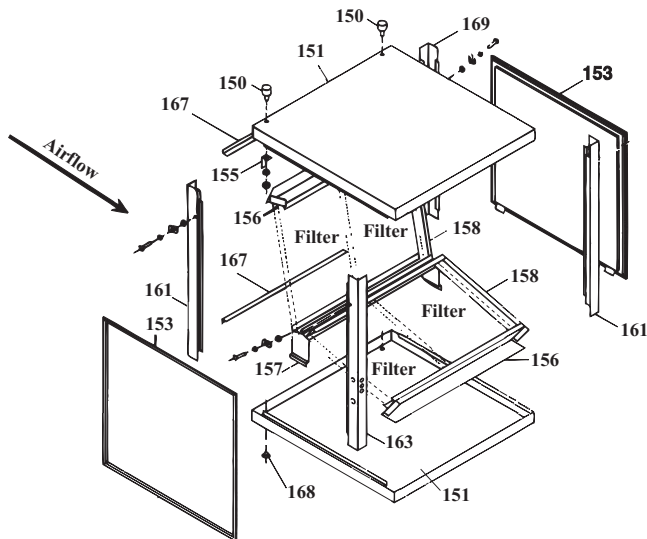

Blower cabinet for Models XC, XE and XJ manufactured prior to August 1975 are not available.

Optional Indoor Blower Cabinet - Models (C)XE, (C)HXE, and XJ

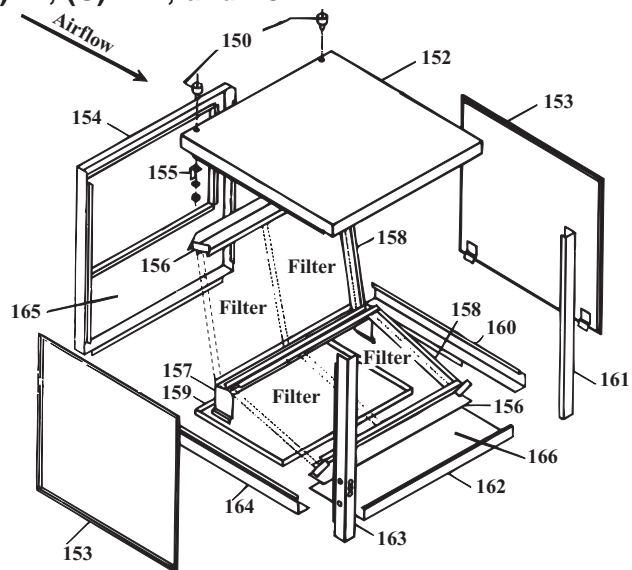

Code	Description	Cabinet	75, 100, 125	150, 175	200, 225	250, 300	350	400
173	Return Air Opening Screen (not illustrated) for Indoor Blower Cabinets	Standard	114468 20 x 29	114469 25-1/2 x 29	114470 30-3/4 x 32	114471 39-1/4 x 32	114472 44-3/4 x 32	114473 50-1/4 x 32
		with Dampers	114474 27-5/16 x 29-3/8	114475 32-3/4 x 29-3/8	114476 38-1/4 x 29-3/8	114477 46-1/2 x 29-3/8	114478 52 x 29-3/8	110983 57-1/2 x 29-3/8

Blower Cabinet - Outdoor Models

Code	Component Description	75, 100, 125	150, 175	200, 225	250, 300	350	400
189	Complete Blower Cabinet (less filter rack and filters)	84215	84216	84217	84218	84219	84220
190	Cabinet Top with Insulation	11825	11842	11767	11856	11862	11777
191	Blower Cabinet Door with Insulation	15457	15457	15459	15459	15459	15459
182	Blower Cabinet End Panel with Outside Air Opening	12074	12410	11539	12413	12028	11588
	Blower Cabinet End Panel without Outside air opening (return air only)	15322	15323	15324	15325	15326	15327
193	Cabinet End Panel with 30% Outside Air and Manual Damper	12389	12349	11375	12116	12356	11384
	Cabinet End Panel with 30% Outside Air and Motorized Damper	37621	37623	37625	37627	37629	37631
194	Cabinet Rear Bottom Section	11526	11533	11392	11571	11580	11393
195	Left Corner Support	11517	11517	11210	11210	11210	11210
196	Right Corner Support	11519	11519	19982	19982	19982	19982
197	Cabinet Bottom Left Side	11203	11203	11203	11203	11203	11203
198	Cabinet Bottom Right Side	11204	11204	11204	11204	11204	11204
199	Filter Rack Assembly	24501	24503	24505	24507	24509	24511
200	Filter Support Member Assembly	19704	19710	19717	19723	19729	19736
201	Intermediate Filter Support	19708	19715	19721	19727	19734	19742
202	Filter Stops	--	19714	--	--	19733	19740
		--	19714	--	--	--	19741
203	Filters, 1" disposable	(2)16448 20x20	(2)16448 20x20	(2)16445 16x20	(2)16445 16x20	(1)16448 20x20	(3)16447 16x25
				(2)16447 16x25	(2)16447 16x25	(3)16446 20x25	(2)16446 20x25
204	Insulation for End Panel	11158	11165	11167	11176	11180	11184
205	Insulation for Bottom Panel	26102	12307	12328	12328	26103	12329
206	Spray Adhesive for Insulation, 13-3/4 ounce can, P/N 112225						

Replacement Door Latch Kit, P/N 112974, for all Cabinets

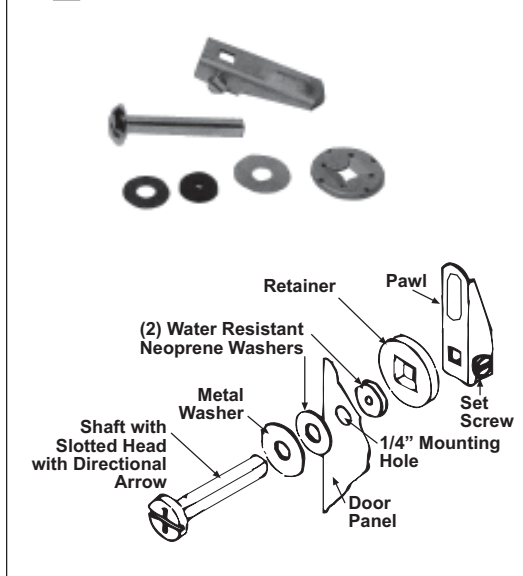

Outdoor Blower Cabinet for Model Series REB, RPBE, RPVE, and RXE

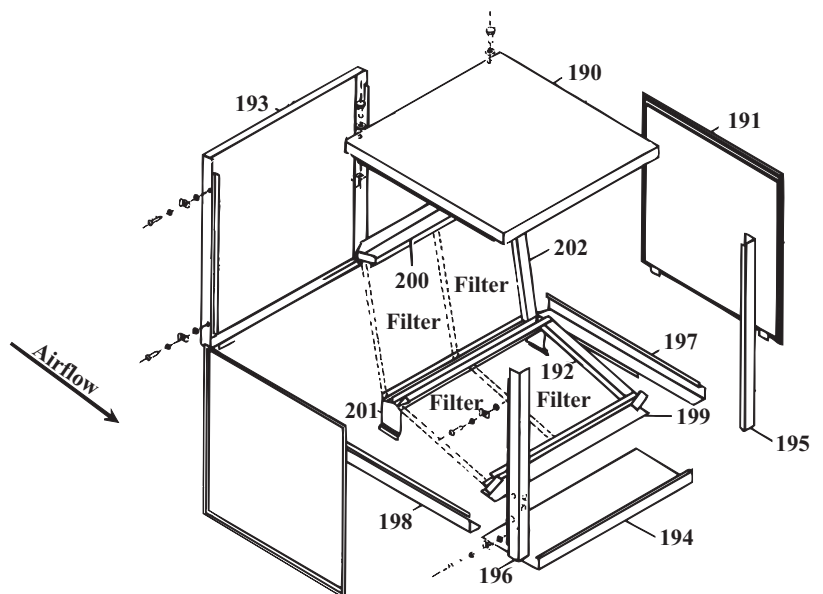

Blower cabinet for Sizes 75-100 manufactured prior to January 1979 are not available.

Replacement Motors and Starters

Replacement motor **contactor**, #425CXX-11, is P/N **122376** with 24 volt coil for 115, 208, 230, or 460 supply voltage. Motors in the tables that are not highlighted have either a motor contactor or an optional starter.



Replacement IEC Starters and Overloads (P/N's are listed in the motor tables) - When ordering a replacement IEC starter (contactor) or overload, check the manufacturer's number on both parts. If the number is different than that listed, both components must be replaced.

Motors that are highlighted in gray in the motor tables do not have internal overload protection and must be used with the IEC motor starter and overload listed in the table.

If the motor has a NEMA starter, see the replacement parts on the right.

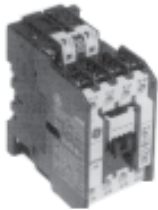

IEC Starter (Contactor)



IEC Adjustable Overload

IEC Starter (contactor) and overload are mounted on rail, P/N **111387**

Replacement NEMA Starters and Contactors

All systems in this book manufactured prior to 9/91 were equipped with a NEMA motor starter or contactor.

NEMA Motor Starters				Motor Contactor		
P/N	Size	Type	Coil Voltage	P/N	Voltage	Coil Voltage
39919	0	Open	24 Volt	Contactor mounted in Box with Cover		
37953	0	Enclosed	200/208 Volt	95527	115V	115 Volt
37954	0	Enclosed	230 Volt	95528	230V	230 Volt
37955	0	Enclosed	460 volt	95526	460V	24 Volt
39920	1	Open	24 Volt	Contactor only (less case)		
39921	2	Open	24 Volt	93662	115	115 Volt
39922	3	Open	24 Volt	93663	230	230 Volt
Holding Coils for NEMA Starters				122376	115,208	24 Volt
					230,460	
P/N	Size	Coil Voltage				
48531	0/1	24 Volt				
48507	0/1	115 Volt				
48509	0/1	208 Volt				
73795	0/1	230 Volt				
48512	0/1	460 Volt				
73601	0/1	575 Volt				
95093	3	24 Volt				
Auxiliary Contact for NEMA Starters						
P/N	Starter Size		Contact			
38088	0, 1, 2		Normally Open Contact			

Replacement Holding Coils for IEC Starters

Voltage	Reznor GE #	P/N	For Use with Contactors Beginning with GE#	Voltage	Reznor GE #	P/N	For Use with Contactors Beginning with GE#
24	LB1A-C	151280	CL00; CL01; CL02; CL25	208	LB3A-L	151288	CL04; CL45
120	LB1A-J	151281	CL00; CL01; CL02; CL25	230	LB3A-S	151289	CL04; CL45
208	LB1A-L	151282	CL00; CL01; CL02; CL25	460	LB3A-U	151290	CL04; CL45
230	LB1A-S	151283	CL00; CL01; CL02; CL25	575	LB3A-Y	151291	CL04; CL45
460	LB1A-U	151284	CL00; CL01; CL02; CL25	208	LB4A-L	151292	CL06; CL07; CL08; CL09
575	LB1A-Y	151285	CL00; CL01; CL02; CL25	230	LB4A-S	151293	CL06; CL07; CL08; CL09
24	LB3A-C	151286	CL04; CL45	460	LB4A-U	151294	CL06; CL07; CL08; CL09
120	LB3A-J	151287	CL04; CL45				

Motors and Starters for Model XE (for rooftop models, see page 16; for other models, see page 18)

Motors that are highlighted in gray do not have internal overload protection and must be used with the motor starter and overload listed.

Motor					Reznor	Replaces			Contactor	Reznor	Overload		Reznor	
Type	HP	Mfr	FLA	Mfr No.	P/N	P/N	V	ph	GE#	P/N	GE#	Min	Max	P/N
OPEN	1/4	A.O.Smith	5.1	316P260	93545		120	1	CL00A310T-1	151275	RTA1-L	4.00	6.30	151191
OPEN	1/4	A.O.Smith	2.1	325P163	115790	85087	208	1	CL00A310T-1	151275	RTA1-J	1.90	2.70	151189
OPEN	1/4	A.O.Smith	2.3	325P163	115790	85087	240	1	CL00A310T-1	151275	RTA1-J	1.90	2.70	151189
OPEN	1/4	Century	1.1	H200	115864		208	3	CL00A310T-1	151275	RTA1-G	1.00	1.50	151187
OPEN	1/4	Century	1.4	H200	115864		240	3	CL00A310T-1	151275	RTA1-G	1.00	1.50	151187
OPEN	1/4	Century	0.75	H200	115864		480	3	CL00A310T-1	151275	RTA1-F	0.65	1.10	151186
OPEN	1/3	A.O.Smith	5.5	316P308	93546		120	1	CL00A310T-1	151275	RTA1-L	4.00	6.30	151191
OPEN	1/3	Century	3.2	F153	115862	7802	208	1	CL00A310T-1	151275	RTA1-K	2.50	4.10	151190
OPEN	1/3	Century	2.8	F153	115862	7802	240	1	CL00A310T-1	151275	RTA1-K	2.50	4.10	151190
OPEN	1/3	Century	1.4	H260	115863		208	3	CL00A310T-1	151275	RTA1-G	1.00	1.50	151187
OPEN	1/3	Century	1.6	H260	115863		240	3	CL00A310T-1	151275	RTA1-H	1.30	1.90	151188
OPEN	1/3	Century	0.8	H260	115863		480	3	CL00A310T-1	151275	RTA1-F	0.65	1.10	151186
OPEN	1/2	Century	8.8	327P828	102627		120	1	CL00A310T-1	151275	RTA1-N	8.00	12.00	151193
OPEN	1/2	A.O.Smith	5.1	327P828	102627		208	1	CL00A310T-1	151275	RTA1-L	4.00	6.30	151191
OPEN	1/2	A.O.Smith	4.4	327P828	102627		240	1	CL00A310T-1	151275	RTA1-L	4.00	6.30	151191
OPEN	1/2	Century	2.1	H880	159183	13443	208	3	CL00A310T-1	151275	RTA1-J	1.90	2.70	151189
OPEN	1/2	Century	2	H880	159183	13443	240	3	CL00A310T-1	151275	RTA1-K	1.90	2.70	151190
OPEN	1/2	Century	1	H880	159183	13443	480	3	CL00A310T-1	151275	RTA1-H	0.65	1.10	151188
OPEN	3/4	A.O.Smith	11	312P629	93548		120	1	CL01A310T-1	151276	RTA1-P	10.00	16.00	151194
OPEN	3/4	A.O.Smith	6.3	312P629	93548		208	1	CL00A310T-1	151275	RTA1-M	5.50	8.50	151192
OPEN	3/4	A.O.Smith	5.5	312P629	93548		240	1	CL00A310T-1	151275	RTA1-L	4.00	6.30	151191

Motors and Starters for Model XE - cont'd (for rooftop models, see page 16; for other models, see page 18)

Motors that are highlighted in gray do not have internal overload protection and must be used with the motor starter and overload listed.

Motor					Reznor P/N	Replaces P/N	V	ph	Contactor GE#	Reznor P/N	Overload			Reznor P/N
Type	HP	Mfr	FLA	Mfr No.							GE#	Min	Max	
OPEN	3/4	A.O.Smith	2.9	312P696	36951		208	3	CL00A310T-1	151275	RTA1-K	2.50	4.10	151190
OPEN	3/4	A.O.Smith	2.6	312P696	36951		240	3	CL00A310T-1	151275	RTA1-K	2.50	4.10	151190
OPEN	3/4	A.O.Smith	1.3	312P696	36951		480	3	CL00A310T-1	151275	RTA1-G	1.00	1.50	151187
OPEN	1	A.O.Smith	13	327P297	13685		120	1	CL01A310T-1	151276	RTA1-P	10.00	16.00	151194
OPEN	1	A.O.Smith	7.5	327P297	13685		208	1	CL00A310T-1	151275	RTA1-M	5.50	8.50	151192
OPEN	1	A.O.Smith	6.5	327P297	13685		240	1	CL00A310T-1	151275	RTA1-M	5.50	8.50	151192
OPEN	1	A.O.Smith	3.7	312P703	36580		208	3	CL00A310T-1	151275	RTA1-K	2.50	4.10	151190
OPEN	1	A.O.Smith	3.2	312P703	36580		240	3	CL00A310T-1	151275	RTA1-K	2.50	4.10	151190
OPEN	1	A.O.Smith	1.6	312P703	36580		480	3	CL00A310T-1	151275	RTA1-H	1.30	1.90	151188
OPEN	1	Century	1.4	E101656	158175	105533	575	3	CL00A310T-1	151275	RTA1-G	1.00	1.50	151187
OPEN	1.5	Century	15	C688	105527		120	1	CL02A310T-1	151277	RTA1-P	10.00	16.00	151194
OPEN	1.5	A.O.Smith	8.3	311P763	4082		208	1	CL00A310T-1	151275	RTA1-N	8.00	12.00	151193
OPEN	1.5	A.O.Smith	7.5	311P763	4082		240	1	CL00A310T-1	151275	RTA1-M	5.50	8.50	151192
OPEN	1.5	Century	5.6	H884	115859	16081	208	3	CL00A310T-1	151275	RTA1-L	4.00	6.30	151191
OPEN	1.5	Century	5	H884	115859	16081	240	3	CL00A310T-1	151275	RTA1-L	4.00	6.30	151191
OPEN	1.5	Century	2.7	H884	115859	16081	480	3	CL00A310T-1	151275	RTA1-J	1.90	2.70	151189
OPEN	1.5	Century	2	E101657	158162	105534	575	3	CL00A310T-1	151275	RTA1-J	1.90	2.70	151189
OPEN	2	Century	20.4	V102	105528		120	1	CL25A310T-1	151278	RTA1-T	17.50	22.00	151197
OPEN	2	Century	10	V102	105528		208	1	CL00A310T-1	151275	RTA1-N	8.00	12.00	151193
OPEN	2	Century	10.2	V102	105528		240	1	CL01A310T-1	151276	RTA1-P	10.00	16.00	151194
OPEN	2	Century	7	H886	159327	13697	208	3	CL01A310T-1	151276	RTA1-M	5.50	8.50	151192
OPEN	2	Century	6.6	H886	159327	13697	240	3	CL01A310T-1	151276	RTA1-M	5.50	8.50	151192
OPEN	2	Century	3.3	H886	159327	13697	480	3	CL01A310T-1	151276	RTA1-K	2.50	4.10	151190
OPEN	2	Century	2.4	E101658	158176	105535	575	3	CL01A310T-1	151276	RTA1-J	1.90	2.70	151189
OPEN	3	Century	9.1	H845	159185	31693	208	3	CL01A310T-1	151276	RTA1-N	8.00	12.00	151193
OPEN	3	Century	8.4	H845	159185	31692	240	3	CL01A310T-1	151276	RTA1-N	8.00	12.00	151193
OPEN	3	Century	4.2	H845	159185	31692	480	3	CL01A310T-1	151276	RTA1-L	4.00	6.30	151191
OPEN	3	Century	3.6	181532-01	120019		575	3	CL01A310T-1	151276	RTA1-K	2.50	4.10	151190
OPEN	5	Century	13.4	181159-01	113371	85748	208	3	CL01A310T-1	151276	RTA1-P	10.00	16.00	151194
OPEN	5	Century	13.2	8-181159-01	113371	85748	240	3	CL01A310T-1	151276	RTA1-P	10.00	16.00	151194
OPEN	5	Century	6.6	8-181159-01	113371	85748	480	3	CL01A310T-1	151276	RTA1-M	5.50	8.50	151192
OPEN	5	Century	5.4	8-181533-01	120020	105829	575	3	CL01A310T-1	151276	RTA1-L	4.00	6.30	151191

Motor					Reznor P/N	Replaces P/N	V	ph	Contactor GE#	Reznor P/N	Overload			Reznor P/N
Type	HP	Mfr	FLA	Mfr No.							GE#	Min	Max	
TEFC	1/4	Century	3.6	STOCK #904	105566		120	1	CL01A310T-1	151276	RTA1-K	2.50	4.10	151190
TEFC	1/4	Century	2.2	108152	16074		208	1	CL01A310T-1	151276	RTA1-J	1.90	2.70	151189
TEFC	1/4	Century	1.9	108152	16074		240	1	CL01A310T-1	151276	RTA1-H	1.30	1.90	151188
TEFC	1/4	Century	1.6	125439	16075		208	3	CL01A310T-1	151276	RTA1-H	1.30	1.90	151188
TEFC	1/4	Century	1.4	125439	16075		240	3	CL01A310T-1	151276	RTA1-G	1.00	1.50	151187
TEFC	1/4	Century	0.7	125439	16075		480	3	CL01A310T-1	151276	RTA1-F	0.65	1.10	151186
TEFC	1/3	Century	4.6	E316	159331		120	1	CL01A310T-1	151276	RTA1-L	4.00	6.30	151191
TEFC	1/3	Century	2.3	E317	159332		208	1	CL01A310T-1	151276	RTA1-J	1.90	2.70	151189
TEFC	1/3	Century	2.4	E317	159332		240	1	CL01A310T-1	151276	RTA1-J	1.90	2.70	151189
TEFC	1/3	Century	1.2	E324	158164		208	3	CL01A310T-1	151276	RTA1-G	1.00	1.50	151187
TEFC	1/3	Century	1.2	H261	105567		240	3	CL01A310T-1	151276	RTA1-G	1.00	1.50	151187
TEFC	1/3	Century	0.6	H261	105567		480	3	CL01A310T-1	151276	RTA1-D	0.40	0.65	151184
TEFC	1/2	Century	7	E318	159333		120	1	CL01A310T-1	151276	RTA1-M	5.50	8.50	151192
TEFC	1/2	Century	3.4	E319	159334		208	1	CL01A310T-1	151276	RTA1-K	2.50	4.10	151190
TEFC	1/2	Century	3.5	E319	159334		240	1	CL01A310T-1	151276	RTA1-K	2.50	4.10	151190
TEFC	1/2	Century	2.3	E325	158163		208	3	CL01A310T-1	151276	RTA1-J	1.90	2.70	151189
TEFC	1/2	Century	2	119851	16077		240	3	CL01A310T-1	151276	RTA1-J	1.90	2.70	151189
TEFC	1/2	Century	1	119851	16077		480	3	CL01A310T-1	151276	RTA1-F	0.65	1.10	151186
TEFC	1/2	Century	0.7	H276	105568		575	3	CL01A310T-1	151276	RTA1-F	0.65	1.10	151186
TEFC	3/4	Century	11	F353	115860		120	1	CL01A310T-1	151276	RTA1-P	10.00	16.00	151194
TEFC	3/4	Century	5.4	F353	115860		208	1	CL01A310T-1	151276	RTA1-L	4.00	6.30	151191
TEFC	3/4	Century	5.5	F353	115860		240	1	CL01A310T-1	151276	RTA1-L	4.00	6.30	151191
TEFC	3/4	Century	2	142198	20371		208	3	CL01A310T-1	151276	RTA1-J	1.90	2.70	151189
TEFC	3/4	Century	2.2	142198	20371		240	3	CL01A310T-1	151276	RTA1-J	1.90	2.70	151189
TEFC	3/4	Century	1.1	142198	20371		480	3	CL01A310T-1	151276	RTA1-F	0.65	1.10	151186
TEFC	3/4	Century	0.8	H461	105569		575	3	CL01A310T-1	151276	RTA1-F	0.65	1.10	151186

Motors and Starters for Model XE - cont'd (for rooftop models, see below; for other models, see page 18)

Motors that are highlighted in gray do not have internal overload protection and must be used with the motor starter and overload listed.

Motor					Reznor P/N	Replaces P/N	V	ph	Contactor GE#	Reznor P/N	Overload			Reznor P/N
Type	HP	Mfr	FLA	Mfr No.							GE#	Min	Max	
TEFC	1	Century	12	159105	174993		120	1	CL01A310T-1	151276	RTA1-P	10.00	16.00	151194
TEFC	1	Century	6.2	159105	174993		208	1	CL00A310T-1	151275	RTA1-M	5.50	8.50	151192
TEFC	1	Century	6	159105	174993		240	1	CL00A310T-1	151275	RTA1-M	5.50	8.50	151192
TEFC	1	Century	3.3	8-159223-01	16080		208	3	CL00A310T-1	151275	RTA1-K	2.50	4.10	151190
TEFC	1	Century	3.4	8-159223-01	16080		240	3	CL00A310T-1	151275	RTA1-K	2.50	4.10	151190
TEFC	1	Century	1.7	8-159223-01	16080		480	3	CL00A310T-1	151275	RTA1-H	1.30	1.90	151188
TEFC	1	Century	1.4	H525	105570		575	3	CL00A310T-1	151275	RTA1-G	1.00	1.50	151187
TEFC	1 1/2	A.O.Smith	16.4	311P402	94347		120	1	CL02A310T-1	151277	RTA1-S	14.50	18.00	151196
TEFC	1 1/2	A.O.Smith	9.5	311P402	94347		208	1	CL00A310T-1	151275	RTA1-N	8.00	12.00	151193
TEFC	1 1/2	A.O.Smith	8.2	311P402	94347		240	1	CL00A310T-1	151275	RTA1-N	8.00	12.00	151193
TEFC	1 1/2	Century	4.3	362272	101286		208	3	CL00A310T-1	151275	RTA1-L	4.00	6.30	151191
TEFC	1 1/2	Century	4.4	362272	101286		240	3	CL00A310T-1	151275	RTA1-L	4.00	6.30	151191
TEFC	1 1/2	Century	2.2	362272	101286		480	3	CL00A310T-1	151275	RTA1-J	1.90	2.70	151189
TEFC	1 1/2	Century	1.8	E127	105665		575	3	CL00A310T-1	151275	RTA1-H	1.30	1.90	151188
TEFC	2	Century	24	K200	105572		120	1	CL04A310M-1	151279	RTA1-U	21.00	26.00	151198
TEFC	2	Century	12	K200	105572		240	1	CL01A310T-1	151276	RTA1-P	10.00	16.00	151194
TEFC	2	Century	6.5	E166	158165		208	3	CL00A310T-1	151275	RTA1-M	5.50	8.50	151192
TEFC	2	Century	5.6	E166	158165		240	3	CL00A310T-1	151275	RTA1-L	4.00	6.30	151191
TEFC	2	Century	2.8	E166	158165		480	3	CL00A310T-1	151275	RTA1-K	2.50	4.10	151190
TEFC	2	Century	2.2	E169	158166		575	3	CL00A310T-1	151275	RTA1-J	1.90	2.70	151189
TEFC	3	Century	8.5	M3559T	159330		208	3	CL00A310T-1	151275	RTA1-N	8.00	12.00	151193
TEFC	3	Century	8.2	M3559T	159330		240	3	CL00A310T-1	151275	RTA1-N	8.00	12.00	151193
TEFC	3	Century	4.1	M3559T	159330		480	3	CL00A310T-1	151275	RTA1-L	4.00	6.30	151191
TEFC	3	Century	3.1	E272	158168		575	3	CL00A310T-1	151275	RTA1-K	2.50	4.10	151190

Motors and Starters for Rooftop Models (for indoor Model XE, go to page 14; for other models, see page 18)

Motors that are highlighted in gray do not have internal overload protection and must be used with the motor starter and overload listed.

Motor					Reznor P/N	Replaces P/N	V	ph	Contactor GE#	Reznor P/N	Overload			Reznor P/N
Type	HP	Mfr	FLA	Mfr No.							GE#	Min	Max	
OPEN	1/4	A.O.Smith	5.1	316P260	93545		120	1	CL00A310T-J	151146	RTA1-L	4	6.3	151191
OPEN	1/4	A.O.Smith	2.1	325P163	115790	85087	208	1	CL00A310T-L	151150	RTA1-J	1.9	2.7	151189
OPEN	1/4	A.O.Smith	2.3	325P163	115790	85087	240	1	CL00A310T-S	151147	RTA1-J	1.9	2.7	151189
OPEN	1/4	Century	1.1	H200	115864		208	3	CL00A310T-L	151150	RTA1-G	1	1.5	151187
OPEN	1/4	Century	1.4	H200	115864		240	3	CL00A310T-S	151147	RTA1-G	1	1.5	151187
OPEN	1/4	Century	0.75	H200	115864		480	3	CL00A310T-U	151148	RTA1-F	0.6	1.1	151186
OPEN	1/3	A.O.Smith	5.5	316P308	93546		120	1	CL00A310T-J	151146	RTA1-L	4	6.3	151191
OPEN	1/3	Century	3.2	F153	115862	7802	208	1	CL00A310T-L	151150	RTA1-K	2.5	4	151190
OPEN	1/3	Century	2.8	F153	115862	7802	240	1	CL00A310T-S	151147	RTA1-K	2.5	4	151190
OPEN	1/3	Century	1.4	H260	115863		208	3	CL00A310T-L	151150	RTA1-G	1	1.5	151187
OPEN	1/3	Century	1.6	H260	115863		240	3	CL00A310T-S	151147	RTA1-H	1.3	1.9	151188
OPEN	1/3	Century	0.8	H260	115863		480	3	CL00A310T-U	151148	RTA1-F	0.6	1.1	151186
OPEN	1/2	Century	8.8	327P828	102627		120	1	CL00A310T-J	151146	RTA1-N	7	10	151193
OPEN	1/2	A.O.Smith	5.1	327P828	102627		208	1	CL00A310T-L	151150	RTA1-L	4	6.3	151191
OPEN	1/2	A.O.Smith	4.4	327P828	102627		240	1	CL00A310T-S	151147	RTA1-L	4	6.3	151191
OPEN	1/2	Century	3	H880	159183	13443	208	3	CL00A310T-L	151150	RTA1-K	2.5	4	151190
OPEN	1/2	Century	2.5	H880	159183	13443	240	3	CL00A310T-S	151147	RTA1-K	2.5	4	151190
OPEN	1/2	Century	1	H880	159183	13443	480	3	CL00A310T-U	151148	RTA1-G	1	1.5	151187
OPEN	3/4	A.O.Smith	11	312P629	93548		120	1	CL01A310T-J	151151	RTA1-P	10	16	151194
OPEN	3/4	A.O.Smith	6.3	312P629	93548		208	1	CL00A310T-L	151150	RTA1-M	5.5	7.5	151192
OPEN	3/4	A.O.Smith	5.5	312P629	93548		240	1	CL00A310T-S	151147	RTA1-L	4	6.3	151191
OPEN	3/4	A.O.Smith	2.9	312P696	36951		208	3	CL00A310T-L	151150	RTA1-K	2.5	4	151190
OPEN	3/4	A.O.Smith	2.6	312P696	36951		240	3	CL00A310T-S	151147	RTA1-K	2.5	4	151190
OPEN	3/4	A.O.Smith	1.3	312P696	36951		480	3	CL00A310T-U	151148	RTA1-G	1	1.5	151187
OPEN	1	A.O.Smith	13	327P297	13685		120	1	CL01A310T-J	151151	RTA1-P	10	16	151194
OPEN	1	A.O.Smith	7.5	327P297	13685		208	1	CL00A310T-L	151150	RTA1-M	5.5	7.5	151192
OPEN	1	A.O.Smith	6.5	327P297	13685		240	1	CL00A310T-S	151147	RTA1-M	5.5	7.5	151192
OPEN	1	A.O.Smith	3.7	312P703	36580		208	3	CL00A310T-L	151150	RTA1-K	2.5	4	151190
OPEN	1	A.O.Smith	3.2	312P703	36580		240	3	CL00A310T-S	151147	RTA1-K	2.5	4	151190
OPEN	1	A.O.Smith	1.6	312P703	36580		480	3	CL00A310T-U	151148	RTA1-H	1.3	1.9	151188
OPEN	1	Century	1.1	E1006	158175	105533	575	3	CL00A310T-Y	151149	RTA1-G	1	1.5	151187

Motors and Starters for Rooftop Models - cont'd (for Model XE, go to page 14; for other models, see page 18)

Motors that are highlighted in gray do not have internal overload protection and must be used with the motor starter and overload listed.

Motor					Reznor P/N	Replaces P/N	V	ph	Contactor GE#	Reznor P/N	Overload			Reznor P/N
Type	HP	Mfr	FLA	Mfr No.							GE#	Min	Max	
OPEN	1.5	Century	15	C688	105527		120	1	CL02A310T-J	151156	RTA1-P	10	16	151194
OPEN	1.5	A.O.Smith	8.3	311P763	4082		208	1	CL00A310T-L	151150	RTA1-N	7	10	151193
OPEN	1.5	A.O.Smith	7.5	311P763	4082		240	1	CL00A310T-S	151147	RTA1-M	5.5	7.5	151192
OPEN	1.5	Century	5.6	H884	115859	16081	208	3	CL00A310T-L	151150	RTA1-L	4	6.3	151191
OPEN	1.5	Century	5	H884	115859	16081	240	3	CL00A310T-S	151147	RTA1-L	4	6.3	151191
OPEN	1.5	Century	2.7	H884	115859	16081	480	3	CL00A310T-U	151148	RTA1-J	1.9	2.7	151189
OPEN	1.5	Century	1.6	E1007	158162	105534	575	3	CL00A310T-Y	151149	RTA1-H	1.3	1.9	151188
OPEN	2	Century	20.4	V102	105528		120	1	CL25A310T-J	151160	RTA1-T	17.5	22	151197
OPEN	2	Century	10	V102	105528		208	1	CL01A310T-L	151155	RTA1-N	7	10	151193
OPEN	2	Century	10.2	V102	105528		240	1	CL01A310T-S	151152	RTA1-P	10	16	151194
OPEN	2	Century	7	H886	159327	13697	208	3	CL00A310T-L	151150	RTA1-M	5.5	7.5	151192
OPEN	2	Century	6.6	H886	159327	13697	240	3	CL00A310T-S	151147	RTA1-M	5.5	7.5	151192
OPEN	2	Century	3.5	H886	159327	13697	480	3	CL00A310T-U	151148	RTA1-K	2.5	4	151190
OPEN	2	Century	2.1	E1008	158176	105535	575	3	CL00A310T-Y	151149	RTA1-J	1.9	2.7	151189
OPEN	3	Century	14	B735	111560	31693	208	1	CL02A310T-L	151159	RTA1-P	10	16	151194
OPEN	3	Century	12.4	B735	111560	31692	240	1	CL01A310T-S	151152	RTA1-P	10	16	151194
OPEN	3	Century	9	H845	159185	31692	208	3	CL00A310T-L	151150	RTA1-N	7	10	151193
OPEN	3	Century	8.6	H845	159185		240	3	CL00A310T-S	151147	RTA1-N	7	10	151193
OPEN	3	Century	4.3	H845	159185		480	3	CL00A310T-U	151148	RTA1-L	4	6.3	151191
OPEN	3	Century	3.6	181532-01	120019		575	3	CL00A310T-Y	151149	RTA1-K	2.5	4	151190
OPEN	5	Century	28	V211	111562		208	1	CL04A310M-L	151169	RTA1-V	25	32	151199
OPEN	5	Century	26	V211	111562	111563	240	1	CL04A310M-S	151166	RTA1-V	25	32	151199
OPEN	5	Century	13.4	181159-01	113371	85748	208	3	CL01A310T-L	151155	RTA1-P	10	16	151194
OPEN	5	Century	13.2	8-181159-01	113371	85748	240	3	CL01A310T-S	151152	RTA1-P	10	16	151194
OPEN	5	Century	6.6	8-181159-01	113371	85748	480	3	CL00A310T-U	151148	RTA1-M	5.5	7.5	151192
OPEN	5	Century	5.4	8-181533-01	120020	105829	575	3	CL00A310T-Y	151149	RTA1-L	4	6.3	151191

Motor					Reznor P/N	Replaces P/N	V	ph	Contactor GE#	Reznor P/N	Overload			Reznor P/N
Type	HP	Mfr	FLA	Mfr No.							GE#	Min	Max	
TEFC	1/4	Century	3.6	STOCK #904	105566		120	1	CL00A310T-J	151146	RTA1-K	2.5	4	151190
TEFC	1/4	Century	2.2	108152	16074		208	1	CL00A310T-L	151150	RTA1-J	1.9	2.7	151189
TEFC	1/4	Century	1.9	108152	16074		240	1	CL00A310T-S	151147	RTA1-H	1.3	1.9	151188
TEFC	1/4	Century	1.6	125439	16075		208	3	CL00A310T-L	151150	RTA1-H	1.3	1.9	151188
TEFC	1/4	Century	1.4	125439	16075		240	3	CL00A310T-S	151147	RTA1-G	1	1.5	151187
TEFC	1/4	Century	0.7	125439	16075		480	3	CL00A310T-U	151148	RTA1-F	0.6	1.1	151186
TEFC	1/3	Century	4.6	STOCK #906	115861		120	1	CL00A310T-J	151146	RTA1-L	4	6.3	151191
TEFC	1/3	Century	2.3	C151	159501	102293	208	1	CL00A310T-L	151150	RTA1-J	1.8	2.7	151189
TEFC	1/3	Century	2.4	C151	159501	102293	240	1	CL00A310T-S	151147	RTA1-J	1.8	2.7	151189
TEFC	1/3	Century	1.2	H261	105567		208	3	CL00A310T-L	151150	RTA1-G	1	1.5	151187
TEFC	1/3	Century	1.2	H261	105567		240	3	CL00A310T-S	151147	RTA1-G	1	1.5	151187
TEFC	1/3	Century	0.6	H261	105567		480	3	CL00A310T-U	151148	RTA1-D	0.4	0.63	151184
TEFC	1/2	Century	7.2	C613	159184	31273	120	1	CL00A310T-J	151146	RTA1-M	5.5	7.5	151192
TEFC	1/2	Century	3.5	C613	159184	31273	208	1	CL00A310T-L	151150	RTA1-K	2.5	4	151190
TEFC	1/2	Century	3.6	C613	159184	31273	240	1	CL00A310T-S	151147	RTA1-K	2.5	4	151190
TEFC	1/2	Century	2.3	119851	16077		208	3	CL00A310T-L	151150	RTA1-J	1.9	2.7	151189
TEFC	1/2	Century	2	119851	16077		240	3	CL00A310T-S	151147	RTA1-J	1.9	2.7	151189
TEFC	1/2	Century	1	119851	16077		480	3	CL00A310T-U	151148	RTA1-F	0.6	1.1	151186
TEFC	1/2	Century	0.7	H276	105568		575	3	CL00A310T-Y	151149	RTA1-F	0.63	0.9	151186
TEFC	3/4	Century	11	F353	115860		120	1	CL01A310T-J	151151	RTA1-P	10	16	151194
TEFC	3/4	Century	5.4	F353	115860		208	1	CL00A310T-L	151150	RTA1-L	4	6.3	151191
TEFC	3/4	Century	5.5	F353	115860		240	1	CL00A310T-S	151147	RTA1-L	4	6.3	151191
TEFC	3/4	Century	2	142198	20371		208	3	CL00A310T-L	151150	RTA1-J	1.9	2.7	151189
TEFC	3/4	Century	2.2	142198	20371		240	3	CL00A310T-S	151147	RTA1-J	1.9	2.7	151189
TEFC	3/4	Century	1.1	142198	20371		480	3	CL00A310T-U	151148	RTA1-F	0.6	1.1	151186
TEFC	3/4	Century	0.8	H461	105569		575	3	CL00A310T-Y	151149	RTA1-F	0.6	1.1	151186
TEFC	1	Century	12	159105	174993	43270	120	1	CL01A310T-J	151151	RTA1-P	10	16	151194
TEFC	1	Century	6.2	159105	174993		208	1	CL00A310T-S	151147	RTA1-M	5.5	7.5	151192
TEFC	1	Century	6	159105	174993	43270	240	1	CL00A310T-S	151147	RTA1-M	5.5	7.5	151192
TEFC	1	Century	3.3	8-159223-01	16080		208	3	CL00A310T-L	151150	RTA1-K	2.5	4	151190
TEFC	1	Century	3.4	8-159223-01	16080		240	3	CL00A310T-S	151147	RTA1-K	2.5	4	151190

Motors and Starters for Rooftop Models - cont'd (for Model XE, go to page 14; for other models, see below)

Motors that are highlighted in gray do not have internal overload protection and must be used with the motor starter and overload listed.

Motor					Reznor P/N	Replaces P/N	V	ph	Contactor GE#	Reznor P/N	Overload			Reznor P/N
Type	HP	Mfr	FLA	Mfr No.							GE#	Min	Max	
TEFC	1	Century	1.7	8-159223-01	16080		480	3	CL00A310T-U	151148	RTA1-H	1.3	1.9	151188
TEFC	1	Century	1.4	H525	105570		575	3	CL00A310T-Y	151149	RTA1-G	1	1.5	151187
TEFC	1 1/2	A.O.	16.4	311P402	94347		120	1	CL02A310T-J	151156	RTA1-S	14.5	17.5	151196
TEFC	1 1/2	A.O.	9.5	311P402	94347		208	1	CL00A310T-L	151150	RTA1-N	7	10	151193
TEFC	1 1/2	A.O.	8.2	311P402	94347		240	1	CL00A310T-S	151147	RTA1-N	7	10	151193
TEFC	1 1/2	Century	4.3	362272	101286		208	3	CL00A310T-L	151150	RTA1-L	4	6.3	151191
TEFC	1 1/2	Century	4.4	362272	101286		240	3	CL00A310T-S	151147	RTA1-L	4	6.3	151191
TEFC	1 1/2	Century	2.2	362272	101286		480	3	CL00A310T-U	151148	RTA1-J	1.9	2.7	151189
TEFC	1 1/2	Century	1.6	E127	105665		575	3	CL00A310T-Y	151149	RTA1-H	1.3	1.9	151188
TEFC	2	Century	24	K200	105572		120	1	CL04A310M-J	151165	RTA1-U	21	26	151198
TEFC	2	Century	12	K200	105572		240	1	CL01A310T-S	151152	RTA1-P	10	16	151194
TEFC	2	Century	6.5	E166	158165	101288	208	3	CL00A310T-L	151150	RTA1-M	5.5	7.5	151192
TEFC	2	Century	5.8	E166	158165	101288	240	3	CL00A310T-S	151147	RTA1-L	4	6.3	151191
TEFC	2	Century	2.9	E166	158165	101288	480	3	CL00A310T-U	151148	RTA1-K	2.5	4	151190
TEFC	2	Century	2.3	E169	158166	105573	575	3	CL00A310T-Y	151149	RTA1-J	1.9	2.7	151189
TEFC	3	Century	30	K222	111564		120	1	CL04A310M-J	113505	RTA1-V	25	32	151199
TEFC	3	Century	15	K222	111564		240	1	CL02A310T-S	151157	RTA1-P	10	16	151194
TEFC	3	Baldor	8.5	M3559T	159330	111565	208	3	CL00A310T-L	151150	RTA1-N	7	10	151193
TEFC	3	Baldor	8.2	M3559T	159330	111565	240	3	CL00A310T-S	151147	RTA1-N	7	10	151193
TEFC	3	Baldor	4.1	M3559T	159330	111565	480	3	CL00A310T-U	151148	RTA1-L	4	6.3	151191
TEFC	3	Century	3	E272	158168	111566	575	3	CL00A310T-Y	151149	RTA1-K	2.5	4	151190
TEFC	5	Century	13.2	E241	155048	111568	208	3	CL01A310T-L	151155	RTA1-P	10	16	151194
TEFC	5	Century	12	E241	155048	111568	240	3	CL01A310T-S	151152	RTA1-P	10	16	151194
TEFC	5	Century	6	E241	155048	111568	480	3	CL00A310T-U	151148	RTA1-L	4	6.3	151191
TEFC	5	Century	4.8	E273	158170	111569	575	3	CL00A310T-Y	151149	RTA1-L	4	6.3	151191
TEFC	5	Century	22.8	K223	111567		240	1	CL04A310M-S	151166	RTA1-U	21	26	151198

Replacement Motors and Fan Blades for Obsolete Heaters

Motor sizes for old style Models XB, XC, XE, XJ, XD, DFAH

Select motor from the motor table on pages 16-17.

XB, XC, XE, XJ		XD		DFAH	
Size	HP	Size	HP	Size	HP
50 through 150	1/4	100, 175	1/2	500, 600	1-1/2
175, 200	1/3	200 through 300	3/4	700, 800	2
225, 250	1/2	350, 400	1		
300, 350	3/4				

Functional Replacement Fan Type Motors for Model UA and XA Units - All motors are 115/60/1; all motors are cradle mounted.

Heater Model and Size	HP	FR	Mfg	Style	RPM	Shaft	115/60/1 - P/N
UA 25, 35, 40, *XA50	12MM		GE	KSPIEL774H	1000	Thread	Not available from Reznor
UA 50, 60, 75, XA 50, 75	1/40	42	W	319P602	1000/800	1/2	11493
UA 90, 100, 105, XA 100, 125	1/20	D42	W	319P424	1140	1/2	9892
XA 150 and 175	1/8	DT42	W	319P423	1140	1/2	9775
XA 200 and 225	1/6	DT48	C	8-134666	1140	1/2	16072
XA 250 and 300	1/8	DT42	W	319P423	1140	1/2	(2) 9775
XA 350 and 400	1/6	DT48	C	8-134666	1140	1/2	(2) 16072

*Used on XA50 prior to Serial No. OD/N299, March 1963

Fan Blades for Model UA and XA Units

Heater Model and Size	Fan Blade Size	Replacement P/N
UA 25 and 35	9 x 33	Not available from Reznor
UA40, *XA50	10 x 23	Not available from Reznor
UA50, 60; XA0, 75, 100	12 x 32-1/2	47785
UA75	14 x 27-1/2	17909
UA 90, 100, 105	14 x 40-1/2	41004
XA 100 Series 2	15 x 38-1/2	125563 (replaces 3701)
XA125	15 x 38-1/2	125563 (replaces 3701)
XA250 through 225	18 x 33-1/2	12625
XA 250 and 300	16 x 36-1/2	45946
XA 350 and 400	18 x 33-1/2	12625

*Used on XA50 prior to Serial No. OD/N299, March 1963

Drive Components

Model Size	Motor HP	RPM Option No. (See Key below drive chart)	Drive Components							
			Blower Pulley			Motor Pulley			V-Belt	
75, 100, 125	1/4 and 1/3	AM2, AM3	116396	AL84	3/4	4074	1VL34	1/2	6183	4L420
		AM4	116395	AL74	3/4	4074	1VL34	1/2	7948	4L400
		AM5, AM6, AM7	116394	AL64	3/4	4074	1VL34	1/2	7949	4L390
		AM8, AM9, AM10, AM11, AM12, AM13	116393	AL54	3/4	4074	1VL34	1/2	10960	4L370
	1/2, 3/4, 1, 1-1/2, 2	AM5, AM6, AM7, AM8, AM9, AM10	116394	AL64	3/4	7962	1VL40	5/8	7948	4L400
		AM11, AM12, AM13	116395	AL74	3/4	13013	1VM50	5/8	50472	A45
		AM14, AM15, AM16	116394	AL64	3/4	13013	1VM50	5/8	50470	A43
150, 175, 200, 225	1/4 and 1/3	AM2, AM3	116400	AL84	1	4074	1VL34	1/2	6185	4L450
		AM4, AM5	116399	AL74	1	4074	1VL34	1/2	3938	4L430
		AM6, AM7, AM8, AM9	116399	AL74	1	13491	1VL40	1/2	6184	4L440
150, 175, 200, 225, 350, 400	1/2, 3/4, 1, 1-1/2, 2	AM2	116402	AL204	1	7962	1VL40	5/8	65403	A48
		AM3, AM4	116401	AL94	1	7962	1VL40	5/8	3185	4L450
		AM5	116402	AL104	1	13013	1VM50	5/8	12365	4L510
		AM6, AM7	116399	AL74	1	7962	1VL40	5/8	3184	4L440
		AM8	116401	AL94	1	13013	1VM50	5/8	50474	A47
		AM9, AM10	116398	AL64	1	7962	1VL40	5/8	3938	4L430
		AM11, AM12, AM13	116399	AL74	1	13013	1VM50	5/8	3938	4L430
		AM12	116399	AL74	1	13013	1VM50	5/8	50474	A47
	AM13, AM14, AM15, AM16	116398	AL64	1	13013	1VM50	5/8	50474	A47	
	AM17, AM18, AM19, AM20, AM21	116397	AL54	1	13013	1VM50	5/8	52966	A44	
	3	AM13, AM14, AM15, AM16, AM17, AM18, AM19, AM20, AM21	116403	AL114	1	37451	1VM50	7/8	65404	A51
5	AM13	116404	AL124	1	37451	1VM50	7/8	50513	A52	
250, 300	1/2, 3/4, 1, 1-1/2, 2	AM3	116399	AL74	1	13580	1VL34	5/8	6184	4L440
		AM4, AM5	116400	AL84	1	7962	1VL40	5/8	3938	4L430
		AM6, AM7	116399	AL74	1	7962	1VL40	5/8	6182	4L410
		AM8, AM9, AM10	116400	AL84	1	13013	1VM50	5/8	6185	4L450
		AM11, AM12, AM13	116399	AL74	1	13013	1VM50	5/8	50472	A45
		AM14, AM15, AM16	116398	AL64	1	13013	1VM50	5/8	50470	A43
		AM17, AM18, AM19, AM20, AM21	116397	AL54	1	13013	1VM50	5/8	50500	A41
	3	AM13, AM14, AM15, AM16, AM17, AM18, AM19	116403	AL114	1	37451	1VM50	7/8	65403	A48

Drive Key:

Option RPM	Option RPM	Option RPM	Option RPM	Option RPM	Option RPM
AM2 451-500	AM7 701-750	AM12 951-1000	AM17 1201-1250	AM22 1451-1500	AM26 1651-1700
AM3 501-550	AM8 751-800	AM13 1001-1050	AM18 1251-1300	AM23 1501-1550	AM27 1701-1750
AM4 551-600	AM9 801-850	AM14 1051-1100	AM19 1301-1350	AM24 1551-1600	AM28 1751-1800
AM5 601-650	AM10 851-900	AM15 1101-1150	AM20 1351-1400	AM25 1601-1650	AM29 1801-1850
AM6 651-700	AM11 901-950	AM16 1151-1200	AM21 1401-1450		

Downturn Plenum Cabinet - Outdoor Models

Downturn Plenum Cabinet for Outdoor Model Series REB, RPBE, RPVE, and RXE

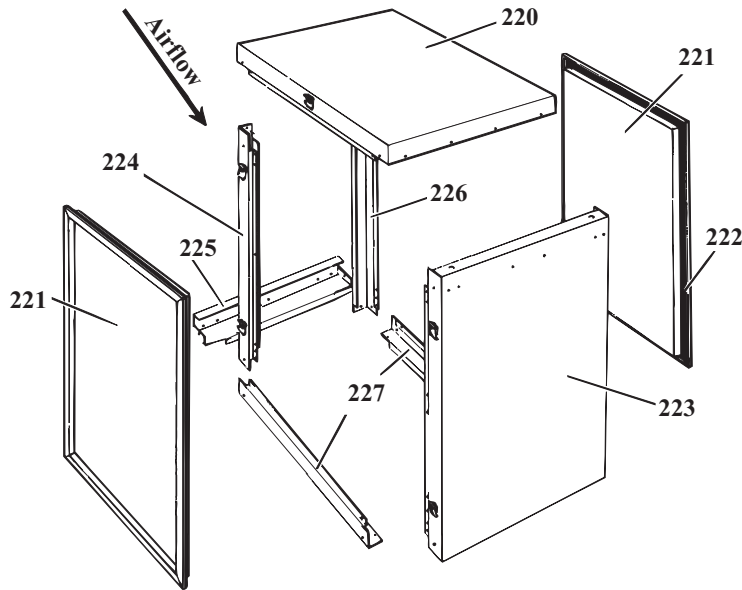

*Cabinet complete as shown

Size	P/N
75-125	17046
150-175	17055
200-225	17063
250-300	17066
350	17120
400	17123

*Plenum cabinet for Sizes 75-100 manufactured prior to January 1979 is not available.

Code	Component Description	75, 100, 125	150, 175	200, 225	250, 300	350	400
220	Cabinet Top	12302	12305	11800	12311	12317	11805
221	Side Panel with Insulation	20639		20666			
222	Door Panel Gasket	82442		82443			
223	End Panel with Insulation	15322		15324	15325	15326	15327
224	Left Corner Support	11517		11210			
225	Cabinet Rear Bottom	11521	11528	11535	11563	11573	11582
226	Right Corner Support	11518		11211			
227	Bottom Left & Right Side	11512					

Outside Air Hood, Dampers, and Inlet Air Controls

Code 250 - Outside Air Hood

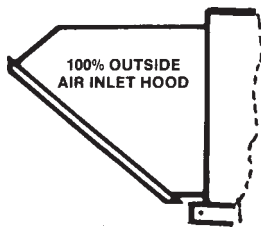

Hood and Damper for 30% Opening



Code 252, Damper Blade

30% Hood (Codes 254-258)



Code 260, Hand Quadrant
Code 261, Support

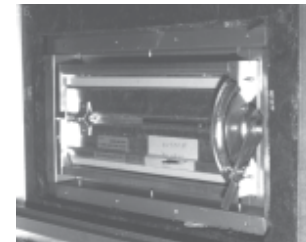

Code	Component Description	75, 100, 125	150, 175	200, 225	250, 300	350	400
250	Outside Air Hood (Same as Option AS2)	12077	12400	11543	12416	12031	11590
251	Damper Assembly for 100% Damper Opening	105421	105422	105423	105424	105425	105426
252	Damper Single Blade, 30% Opening	37710	37711	37712	37713	37714	37715
253	Damper Support Frame - 30% Outside Air, Motorized Damper	37610	37611	37612	37613	37614	37615
254	Air Inlet Shield Top, 30% Outside Air, Manual Damper	12392	12293	11378	12119	12359	11387
	Air Inlet Shield Top, 30% Outside Air, Motorized Damper	37655	37656	37657	37658	37659	37660
255	Air Inlet Shield Right End, 30% Outside Air	11380	11380	11380	11380	11380	11380
	Air Inlet Shield Left End, 30% Outside Air	11379	11379	11379	11379	11379	11379
256	Air Inlet Shield Screen, 30% Outside Air, Manual Damper	12394	11755	11382	12121	12361	11389
	Air Inlet Shield Screen, 30% Outside Air, Motorized Damper	37634	37635	37636	37637	37638	37639
257	Air Inlet Shield Screen Retaining Angle, 30% Outside Air, Manual Damper	12395	12343	11383	12122	12362	11390
	Air Inlet Shield Screen Retaining Angle, 30% Outside Air, Motorized Damper	37648	37649	37650	37651	37652	37653
258	Screen Clamp Angle, 30% Outside Air, Manual Damper	20253	20254	20255	20256	20257	20258
	Screen Clamp Angle, 30% Outside Air, Motorized Damper	37641	37642	37643	37644	37645	37646

Dampers for 100% Openings

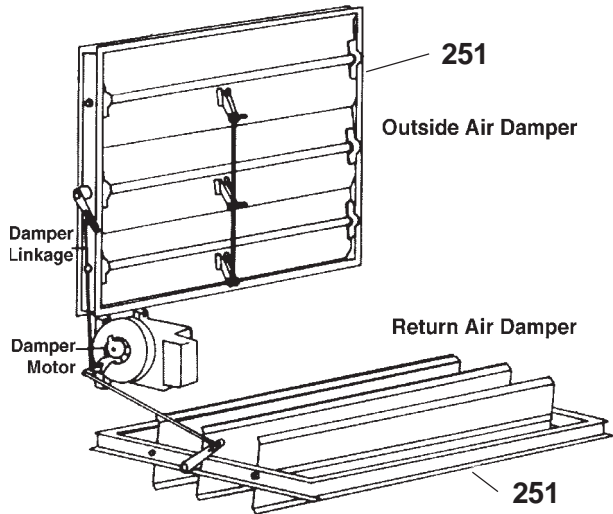

Codes 262-263 - Two-Position Damper Motor



P/N 66276, W/R #3405-21, with one end switch
 P/N 97385, Optional Damper Motor, W/R #3402-9 with two end switches

Codes 264-266, Modulating Damper Motor



P/N 115681, M/H 9175 A1015, less end switch (replaces P/N 53928- see Note below)
 P/N 115682, M/H 9175 D1014, optional damper motor with 2 end switches (replaces P/N 96767)

Minneapolis Honeywell Damper Linkage

273A - used with motors 53928, 87059 & 96767; 273B used with motors 115682, 115683 & 115681.

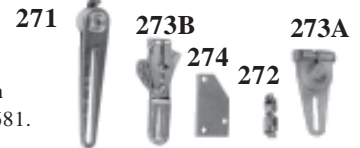

White/Rodgers Damper Linkage



NOTE: When replacing Honeywell damper motor, Reznor P/N 53928, which is no longer available from the manufacturer, it is necessary to change the crank arm. Order P/N 116209, Honeywell #221455A, to use with replacement motor, P/N 115681. If the unit has both outside and return dampers, order the replacement motor, the new crank arm, a 12" return air damper rod (P/N 11561), and a damper arm support plate (P/N 115687).

Code 277, P/N 16110, Potentiometer

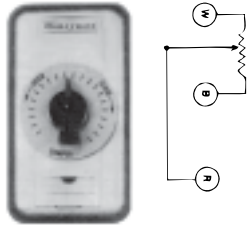

Code 278, P/N 16109, Mixed Air Controller Grommet Clamp, P/N 39224

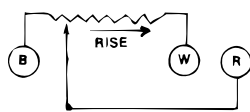

Code 279, P/N 126170, Outside Air Controller (replaces P/N 16108)

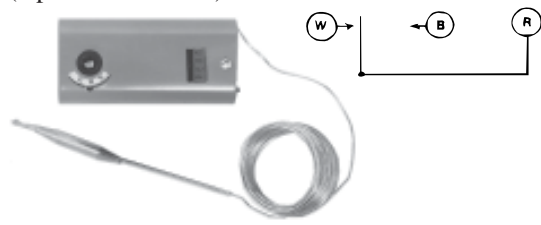

Code	Description of Inlet Air Control Parts	P/N	Components by Option Description - Option AR														
			6	7	8	9	11	12	13	14	15	16	17	18			
260	Hand Quadrant #14004728-001	103502	X				X										
261	Manual Damper Control Bracket	143182	X				X										
262	2-Position Damper Motor (with 1 end switch)	66276	X	X							X					X	
263	2-Position Damper Motor #W/R-3402-9 (2 end switches)	97385	X	X							X					X	
264	Modulating Damper Motor #M9175A1051 (less end switch)	115681					X		X	X		X	X				X
265	Modulating Damper Motor #M9175D1014 (2 end switches)	115682					X		X	X		X	X				X
266	Floating Modulating Damper Motor #M619AB1011	115683										X					X
267A	Damper Rod 1/4 x 12" Long	11561										X					X
267B	Damper Rod 1/4 x 18" Long	11560							X	X		X	X				
268	Damper Rod Arm W-R #135-0007	66278	X														
269A	Crank Arm W/R #135-0002	66277	X									X					X
269B	Crank Arm W/R #135-0003	112553		X								X					X
271	Damper Arm M/H #2026S	12635		X	X	X (2)	X (2)	X (2)	X (2)	X (2)	X	X (2)	X (2)	X (2)	X	X (2)	X (2)
272	Ball and Socket M/H #27518	12636	X	X(2)	X(2)	X (4)	X (4)	X (4)	X (4)	X (4)	X (4)	X (4)	X (4)	X (4)	X (4)	X (4)	X (4)
273A	Crank Arm and Clip M/H #7616BR	20874				X		X	X			X	X				X
273B	Crank Arm M/H #221455A	116209				X		X	X			X	X				X
274	Damper Arm Support Plate	14225					X				X						X
275	Damper Motor Support Assembly	100315	X	X	X			X	X	X	X	X	X	X	X	X	X
276	Air Controller Support Bracket	103758				X		X	X	X				X			X
277	Potentiometer M/H #112894FA	16110								X		X					X
278	Mixed Air Control M/H #T991A-1004	16109						X	X			X	X				
279	Outdoor Air Controller J/C#A19AAF-120	126170										X	X	X			
280	Damper Arm Adjustment Plate	115687							X	X		X	X				X
281	Auxiliary End Switch only for all M/H Damper Motors, #Q607B1067	113963															
282	Auxiliary Switch Kit (2 switches), M/H 220736B	145881															

NOTE: For damper motor transformer, see page 24, Code 335.

Outlet Boxes and Electrical Components

Outlet Box for Model Series X, RX (see note)

NOTE: This outlet box and cover was used on X and RX Series units manufactured before 6/91. Beginning 6/91, X and RX units have the same outlet box, P/N 24612, and cover, P/N 24616, as the other models.

Outlet Box for X, RX, XE, RXE, REB Series 5, 6 and 8

Cover Extension for XE 75 and 100, P/N 135440
Outlet Box only, P/N 24612
Outlet Box Cover only, P/N 24616

Outlet Box RPV Series 3

Terminal blocks were not used on RPV units prior to Series 3.

Outlet Box only, P/N 24612
Outlet Box Cover only, P/N 24616

Gasket, P/N 17083

Outlet Box RPV Series 5, 6 and 8

Outlet Box only, P/N 24612
Outlet Box Cover only, P/N 24616

Fuse Holder, P/N 60241, on CGA units mfgd prior to 11/89

Patch Plate, P/N 9814

Code 300 Limit Control

P/N 50417, Opens 125°F, Closes 105°F
P/N 50418, Opens 145°F

Code 301 - Limit Shield

P/N 12229 - used on X and RX Series units
P/N 9704 - used on RPV Series units
P/N 54151 - used on X and RX Series units

Code 302 - Fan Control, P/N 10357

Code 303 - Blocked Vent Switch

Models	Size	Setting	Color Code	Switch	Gasket	Models	Size	Setting	Color Code	Switch	Gasket
X	75	150°F	White	112753	103256	CX	75	150°F	White	112753	103256
HX	100	200°F	Blue	136736	103256	HXCX	100	175°F	Green	112754	103256
XE	125	200°F	Blue	136736	103256	CXE	125	175°F	Green	112754	103256
HXE	150	150°F	White	112753	103256	HCXE	175	175°F	Green	112754	103256
	175	175°F	Green	112754	103256						
	200	175°F	Green	112754	103256						
	225	175°F	Green	112754	103256		225	175°F	Green	112754	103256
	250	150°F	White	112753	103256		250	150°F	White	112753	103256
	300	175°F	Green	112754	103256		300	175°F	Green	112754	103256
	D300	150°F	White	112753	103256		D300	150°F	White	112753	103256
	350	175°F	Green	112754	103256		350	175°F	Green	112754	103256
	400	200°F	Blue	136736	103256		400	175°F	Green	112754	103256

Code 304 - Combustion Air Pressure Switch (Same as Code 73, page 7)

P/N 68266, Tridelta FS4100-4871, setpoint 0.58±.05" w.c.
 - order when switch is on the wall above the electrical box

For altitudes above 4000 ft, order **P/N 113234, setpoint 0.52±.05"**

P/N 125133, Tridela FS688-1621 setpoint 0.58±.05" w.c.
 - order when switch is mounted inside the electrical box

For altitudes above 4000 ft, order **P/N 125134, setpoint 0.52±.05"**

If replacing P/N 68266 with P/N 125133, it is necessary to re-locate the pressure switch. Order sensing tube, P/N 171750, for the venter assembly and sensing tube, P/N 133117, to connect to the switch. Mount switch inside the electrical box; plug holes in wall with screws.

RP Models manufactured prior to 12/91 (Serial No. Date Code AQL) order replacement pressure switch kit, P/N 93033 (see Code 80, page 6)

**Code 305 - Firestat, P/N 42782, Honeywell
#L4029E1029, Manual Reset Opens at 200°F**

P/N 121041, Firestat
Gasket (used with firstat
when installed less cover

P/N 120021, Firestat
Shield (used with
discharge firestat only)



**Code 306 - Ignition
Controller, P/N 97782,
J/C G67BG-5**



**Code 307 - Ignition Controller,
P/N 97547, J/C G770NGC-4**

Timing cycle 120 second lockout



CODE 306 ABOVE
IF THE CONTROL IN THE UNIT LOOKS
LIKE THIS YOU DO NOT NEED THE KIT
AND CAN JUST REPLACE THE
IGNITION CONTROL P/N: WB-31167



CODE 307 ABOVE
IF THE CONTROL IN THE UNIT LOOKS LIKE
THIS YOU DO NOT NEED THE KIT AND CAN
JUST REPLACE THE IGNITION CONTROL
P/N: WB-31168



Code 310
Bracket, P/N 104156 (used with Essex
brand P/N 41700); **P/N 100260** (used with
Honeywell brand P/N 41700 - see Code 309)
Gasket, P/N 7726
Retaining Plate, P/N 7727

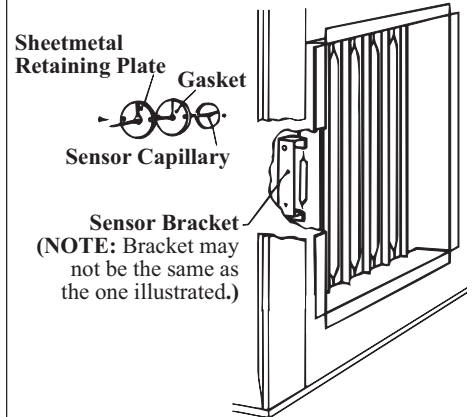

Code 311

**Ductstat Sensor Holder,
#TE6001-1, P/N 115850**



**Ductstat Sensor,
#SET A99BC-25C,
P/N 115851**

(Used in Options AG15-AG20
with Code 312)

Code 312
**- Remote
Electronic
Ductstat**

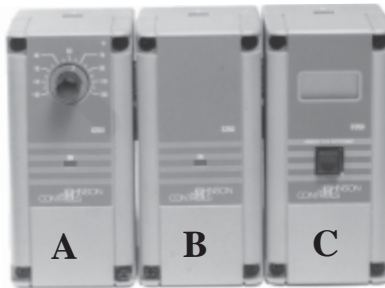

A = Ductstat Temperature Selector Module, J/C
A350AA-1C, **P/N 115848** (used in Options AG 15-20)
B = Stage Adder Module, J/C S350AA-1C, **P/N 115849**
(used in Options AG 15-20)
C = Digital Temperature Display Module, J/C D350AA-
1C, **P/N 115852** (used in Options AG 16, 18, and 20)

**Code 316 - Freezestat
Relay, P/N 103317,
Products Unlimited 9400-
04Q180**



**Code 313 - Low Pressure Gas
Switch (normally open switch)**



For natural gas
units, P/N 93849,
Autunes RLGP
#803112701
For propane gas
units, P/N 149176,
Autunes RLGP
#803112703



**Bracket,
P/N 149397**

**Code 314 - High Gas
Pressure Switch, Autunes
HGP-AM1,
P/N 93850 (normally closed
switch)**



**Vent Limiter, Maxitrol
A1209, P/N 123481**

**Code 315 - Time
Delay Relay,
P/N 46233,
TI 60000GO-17**

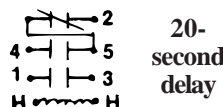















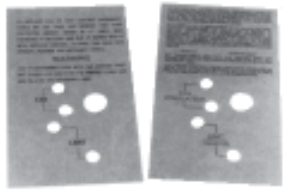



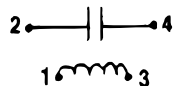

**20-
second
delay**

**Code 317 - P/N 11606, Time
Delay Relay, 30 second
delay, 24 volt coil
(Same as Option BH2)**

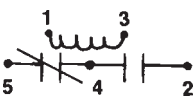

**1 = N. C.
2 = COM
4 = N. O.
H = Coil
H = Coil**

Electrical Components (cont'd)

<p>Code 318, P/N 131450, ECO Device, 306°F (with screw, P/N 82632)</p>  <p>Mounting Plate - X and XE Series, P/N 82633</p>	<p>Code 319, Summer/Winter Switch (used in Options BF4 and CH1) P/N 3745 (6 Amp) Sizes 75 - 200 P/N 8336 (10 Amp) Sizes 225 - 400</p> 	<p>Code 320 - Time Delay Relay, T&B Agastat TMIULA, P/N 89661</p>  <p>Used in freezestat circuit</p>	<p>Codes 321A and 321B Terminal Block, P/N 144972</p>  <p>Terminal Block Adapter, P/N 144973</p> 																																												
<p>Code 322 - Heat Shields</p>  <p>United States, P/N 10188 Canada, P/N 63818</p>	<p>Code 323 - Dirty Filter Switch, P/N 105507, TriDelta AP4434, Field adjustable</p>  <p>Contacts will close @ .17 to 5.0" w.c. ± .06</p>	<p>Code 324 Fuse Holder, P/N 38635</p>  <p>Fu 2.5 Amps, P/N 61542 5 Amp, P/N 90335 8 Amp, P/N 38636</p>	<p>Code 325, Convenience Outlet, P/N 96912</p> 																																												
<p>Code 326 - Convenience Outlet Transformer</p>  <table border="1"> <thead> <tr> <th>P/N</th> <th>Volts IN</th> <th>Volts OUT</th> <th>VA</th> </tr> </thead> <tbody> <tr> <td>86991</td> <td>208</td> <td>115</td> <td>250</td> </tr> <tr> <td>86985</td> <td>230-460</td> <td>115</td> <td>300</td> </tr> <tr> <td>105202</td> <td>230-460-575</td> <td>115</td> <td>300</td> </tr> </tbody> </table>	P/N	Volts IN	Volts OUT	VA	86991	208	115	250	86985	230-460	115	300	105202	230-460-575	115	300	<p>Code 327 - RBM Relay, P/N 14747, #84-20102-101 SPST</p> <p>(One required on RPV prior to Series 3. Two required on Series 3; one is locking relay, one is venter relay.)</p> 	<p>Code 328 - Post Purge Relay, P/N 11886, Thermodisc 32711, for all RPV units prior to Series 5 P/N 46233 Time Delay Relay</p> <p>Coil = A _____ H Coil = B _____ H COM = 1 _____ 5 N.O. = 2 _____ 4 N. C. = 3 _____ 2</p> 																													
P/N	Volts IN	Volts OUT	VA																																												
86991	208	115	250																																												
86985	230-460	115	300																																												
105202	230-460-575	115	300																																												
<p>Code 329 - Relay, P/N 98118, Exxex 134-20102-101, 24V coil</p>  	<p>Code 330 - SPDT Relay, 24V coil, P/N 18549, #RBM 84-20103-301 (Same as Option BG3 and part of Option BG5)</p>  	<p>Code 331 - Reverse Flow Limit, P/N 103323, #60T11-313154, auto reset</p> 	<p>Code 332 - High Fire Relay, P/N 103930, Electronic Time Delay Relay, Syracuse Electronics #TIR-024A152 (replaces P/N 28164)</p> <p>Used on Models with Model No. Suffix Y</p> 																																												
<p>Code 333 - Controller for freezestat, high ambient limit, outside air and return air, P/N 126170, J/C A19AAF-12C, 25-225°F (replaces P/N 16108)</p>  <p>Bulb Bracket, P/N 100260</p> <p>Grommet Clamp, P/N 131993 Cable Clamp, P/N 132065</p>	<p>Code 334 - Blower Airflow Switch, P/N 112107, Tridelta FP6605, N.O. non-adjustable setpoint .175" w.c.</p> <p>(Air proving switch, Option BW1)</p> 																																														
<p>Code 335 - Control and Damper Transformer</p> <p>P/N 103054, 225/24/20VA, Basler #BE121625-WAR</p> <p>P/N 103055, 115/24/40VA, Baseler BE141650-WAA</p> <p>P/N 103497, 208/230/24/40VA, Basler #BE2153900</p> <p>P/N 103498, 460/24/40VA, Basler #BE23975001</p> 	<p>Code 336 - KVA Transformer (Primary as listed; 120V Secondary)</p> 	<table border="1"> <thead> <tr> <th>KVA</th> <th>200/208</th> <th>220/240/440/480</th> <th>277</th> <th>575</th> </tr> </thead> <tbody> <tr> <td>.25</td> <td>19807</td> <td>11279</td> <td></td> <td>113556</td> </tr> <tr> <td>.50</td> <td>19808*</td> <td>11100</td> <td>14993*</td> <td></td> </tr> <tr> <td>.75</td> <td>24453*</td> <td>11217</td> <td>14994*</td> <td></td> </tr> <tr> <td>1.0</td> <td>24454*</td> <td>16065</td> <td>14995*</td> <td></td> </tr> <tr> <td>1.5</td> <td>24455*</td> <td>24392*</td> <td>14996*</td> <td></td> </tr> <tr> <td>2.0</td> <td>24456*</td> <td>26628*</td> <td>14997*</td> <td></td> </tr> <tr> <td>3.0</td> <td>24465*</td> <td>26630*</td> <td>14998*</td> <td></td> </tr> <tr> <td>5.0</td> <td>24466*</td> <td>26631*</td> <td>15003*</td> <td></td> </tr> </tbody> </table> <p>*Special order</p>	KVA	200/208	220/240/440/480	277	575	.25	19807	11279		113556	.50	19808*	11100	14993*		.75	24453*	11217	14994*		1.0	24454*	16065	14995*		1.5	24455*	24392*	14996*		2.0	24456*	26628*	14997*		3.0	24465*	26630*	14998*		5.0	24466*	26631*	15003*	
KVA	200/208	220/240/440/480	277	575																																											
.25	19807	11279		113556																																											
.50	19808*	11100	14993*																																												
.75	24453*	11217	14994*																																												
1.0	24454*	16065	14995*																																												
1.5	24455*	24392*	14996*																																												
2.0	24456*	26628*	14997*																																												
3.0	24465*	26630*	14998*																																												
5.0	24466*	26631*	15003*																																												

Switches - Disconnect and Toggle

	Code 337 - Disconnect Switches				
	Description	Outdoor	Same as	Indoor	Same as
	30Amp 300V Non-fusible	40269	Option CP5	40267	Option CP1
	30 Amp 300V Fusible (less fuses)	87147	Option CP6	40268	Option CP2
	30 Amp 600V Non-fusible	50367	Option CP7	50365	Option CP3
30 Amp 600V Fusible (less fuses)	50368	Option CP8	50366	Option CP4	

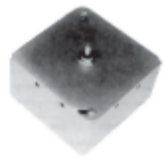
Code 338 - DPDT 3-position Toggle, P/N 40277, Switch in 4x4 box, same as Option CN1	
	

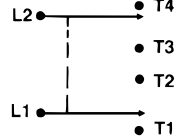
Code 339 - DPDT 3-position Toggle, P/N 101900 (replaces P/N 21816) used in Option CN1 and Remote Console Options RC5, RC6, RC7, RC8, RC10, RC11, RC12	
	

Code 340 - DPST 2-position Toggle, P/N 39732, Switch in 2x4 box, same as Option CN2	
	

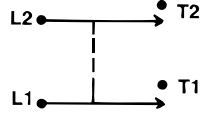
Code 341 - DPST 2-position Toggle, P/N 101902 (replaces P/N 16816) used in Options CN2AG3, AG6, AG8, AG9 and Remote Console Option RC12	
	

Code 342 - SPDT 2-position Toggle, P/N 39733, Switch in 2x4 box, same as Option CN3	
	

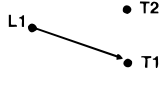
Code 343 - SPDT 2-position Toggle, P/N 101901 (replaces P/N 1052) used in Options CN3, CN4 and Remote Console Option RC13, RC4, RC7, RC8, RC11	
	

Code 344 - SPST On/Off Toggle Switch in 2x4 box, P/N 39748 same as Option CN4	
	
NOTE: When replacing SPST switch with SPDT switch, make wiring connections at appropriate two terminals for switch to function properly.	

Optional Remote Console

Optional RC style remote console includes a mounting ring so that the console may be either recessed or wall mounted. The box is of 16 gauge steel with knockout holes for field wiring. The cover is made of plastic with custom engraving. Order replacement parts for Option RC remote console by part number.



Code 400, Console Box

Knockout Hole Locations in Console Box (measured from centerlines)

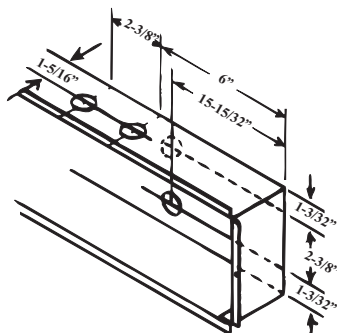

Console Dimensions (wall mounted - not recessed)				
Options RC	Optional Control	Length*	Height*	Depth
1, 2, 3, 4, 5, 6, 7, 8, 9, 10, 12	without	10-3/4"	6-1/2"	2-5/8"
1, 2, 3, 4, 5, 6, 9	with	10-3/4"	6-1/2"	2-5/8"
7, 8, 10, 12	with	15-3/4"	6-1/2"	2-5/8"
11	with & without	15-3/4"	6-1/2"	2-5/8"

*Subtract 5/8" when recessing console (not using wall-mounting ring)

Code	Description	P/N
400	Remote Console Box - 10-1/16 x 4-5/8 x 2-5/8	107010
	Remote Console Box - 15-1/16 x 4-5/8 x 2-5/8	107011
401	Mounting Ring for 10-1/16" long box	107014
	Mounting Ring for 15-1/16" long box	107015
402	Light for Red Lens, Solico #5TD1L-R-B5	101889
403	SPDT Switch, Cutler Hammer #7505K6	101901
404	DPDT Switch, Cutler Hammer #7561K6	101900
405	Single-Stage Heating Thermostat	91919
406	Two-Stage Heating Thermostat	93435
	Single-Stage Heating/Cooling Thermostat	73411
	Two-Stage Heating/Cooling Thermostat	93437
407	Potentiometer (See Code 277, page 21)	16110

Remote Console Components by Option - Options RC1-RC12

Component	Function	In Options	Code
Blower On Light	Lights when blower is operating	RC 1-12	402
Burner On Light	Lights when burners are lit	RC 1-12	402
Dirty Filter Light	Lights when the pressure switch indicates that filters need to be cleaned or replaced	RC 2, 4, 6, 8, 12	402
On/Off Control Switch	On position energizes the unit for thermostat control. "Off" position de-energizes the unit and closes optional automatically controlled outside air dampers.	RC3, 4, 7, 8, 11, 12	403
Summer/Winter/Off Control Switch	Summer position energizes the blower only. Winter position energizes the unit for thermostat control. "Off" position de-energizes the unit and closes optional automatically controlled outside air dampers.	RC 5, 6, 10	404
Heat/Vent/Cool Control Switch	Heat position energizes the unit for thermostat control. "Vent" position energizes the blower and opens optional automatically controlled outside air dampers. "Cool" position energizes the blower, the dampers, and the cooling unit.	RC 7, 8, 11, 12	404
Cooling Light	Lights when cooling system is operating	RC 7, 9, 11, 12	402

Replacement Pilots

CODE 450 - Horizontal Match Lit Pilot - Starting 9/73 for Models X, XA, XB, XC, XD, XE, XG, XJ, PAK, DFAH, HX, HXE, CX, CXE, HCX, HCXE, CPAK; Also used on XL, XLB, CXL, CXLB 125-400



Replacement Pilot Kits		Natural Gas - P/N 110859	Propane Gas - P/N 110860
Code	P/N	Component Description	
1	17890	Natural Gas Pilot with orifice; less pilot tubing, less thermocouple (Baso #J963HXA6218)	
	46136	Propane Gas Pilot with orifice; less pilot tubing, less thermocouple (Baso #J963HXA4211)	
2	46392	Natural Gas Orifice only, #6218	
	42089	Propane Gas Orifice only, #4211	
3	7671	Pilot Tubing, 26" lg for X Series	
	9664	Nut with breakaway ferrule (2 required when replacing pilot tubing)	
3A	5145	Pilot Tubing, 22" lg for XL, XLB, CXL, CXLB 125-400	
	9664	Nut with breakaway ferrule (2 required when replacing pilot tubing)	
4	84761	Thermocouple TC2, 24" lg for X Series	
4A	84760	Thermocouple TC2, 18" lg for XL, XLB, CXL, CXLB 125-400	

This pilot may be used in place of GC #26C23114.

CODE 451 - Horizontal Spark Pilots for Models

Starting 9/73 for X, XA, XB, XC, XD, XE, XG, XJ, PAK, DFAH, CX, CXE, CPAK RX, REB, RXE, RXJ, CRX, CREB, CRXE, RPAK, CRPAK; SC, SCA, SCB, SCE, SCJ Prior to Series 6; RPV, RPVE, RPBE, RPVAK, CRPV, CRPVE, CRPBE, CRPVAK Series 6; RG, CRG, RP, CRP, RGB, CRGB, RPB, CRPB, RGBL, CRGBL, RPBL, CRPBL, SSCBL XL, XLB, CXL, CXLB 125-400

This pilot is also used on:
EEXL, EEXLB, CEEXL, CEEXLB 125-400; EEDU, HEEDU prior to Series 6
RCG 2 through 5 ton with horizontal pilot

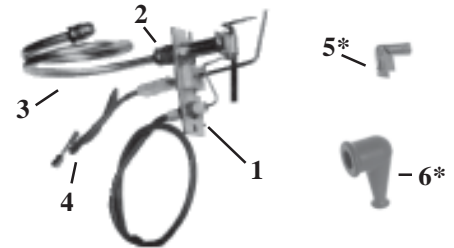

NOTES:

- Horizontal spark pilots for ignition systems other than G60, G65, G67 and G770 are no longer available.
- Kits also apply to models listed with the prefix "H"

*Included in all kits. Used only with the above models equipped with any Model G60 ignition controller, a Model G67BG-2, or a Model G67NG-2. Not used with ignition controller Models G67BG-5 and G770NGC-4. See Instructions on page 4.

- This pilot replaces Baso #J991HXW, natural gas P/N 45150, propane P/N 45141; #J994HXW, natural gas P/N 47303, propane P/N 47384. May be used as a substitution for J993HXW and J999HXW.

Replacement Pilot Kits		Natural Gas - P/N 110861	Propane Gas - P/N 110862
Code	P/N	Component Description	
1	61145	Natural Gas Pilot Assy with orifice, high tension lead, flame probe; less pilot tubing, less flame sensor lead (Baso #J992HXW7221)	
	61146	Propane Gas Pilot Assy with orifice, high tension lead, flame probe; less pilot tubing, less flame sensor lead (Baso #J992HXW9817)	
2	63088	Natural Gas Orifice only, #7221	
	37801	Propane Gas Orifice only, #4209	
3	5145	Pilot Tubing, 22" lg	
	9664	Nut with breakaway ferrule (2 required when replacing pilot tubing)	
4	50450	Sensor lead, 16" lg	
5*	112647	Crimp-on, 90° Rajah terminal connector	
6*	112648	90° Boot Terminal Protector	

*See instructions on page 27.

CODE 452 - Vertical Match Lit Pilot for Models X, XA, XB, XC, XD, XE, XG, XJ, PAK, DFAH prior to 9/73

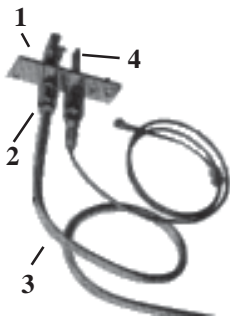

Replacement Pilot Kits		Natural Gas - P/N 110863	Propane Gas - P/N 110864
Code	P/N	Component Description	
1	9661	Natural Gas Pilot Assy with orifice; less pilot tubing, less thermocouple (Baso J915HHA6221)	
	30126	Propane Gas Pilot Assy with orifice; less pilot tubing, less thermocouple (Baso J915HHA4211)	
2	44048	Natural Gas Orifice only, #6221	
	42089	Propane Gas Orifice only, #4211	
3	7671	Pilot Tubing, 26" lg	
	9664	Nut with breakaway ferrule (2 required when replacing pilot tubing)	
4	84761	Thermocouple, TC2, 24" lg	

CODE 453 - Horizontal Match Lit Pilot for Model UA (also Models XL, XLB, CXL, CXLB 30 - 105

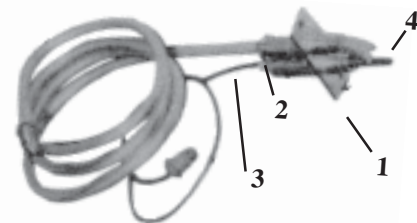

Replacement Pilot Kits		Natural Gas - P/N 110855	Propane Gas - P/N 110856
Code	P/N	Component Description	
1	40964	Natural Gas Pilot Assembly with orifice; less pilot tubing, less thermocouple (Baso #J999HKA4213)	
	40420	Propane Gas Pilot Assembly with orifice; less pilot tubing, less thermocouple (Baso #J999HKA4207)	
2	40966	Natural Gas Orifice only, #4213	
	40965	Propane Gas Orifice only, #4207	
3	5145	Pilot Tubing, 22" long	
	9664	Nut with breakaway ferrule (2 required when replacing pilot tubing)	
4	84761	Thermocouple, TC2-24" long	

CODE 454 - Vertical Spark Pilot for Models RPV, RPBE, RPVE, RPVJ, RPVAK, HRPV, HRPBE, HRPVE, CRPV, HCRPV, CRPBE, HCRPBE, CRPVE, HCRPVE; CRPVAK prior to Series 6 and RCG 7-12/, 10 ton equipped with G60 or G67 ignition Controller

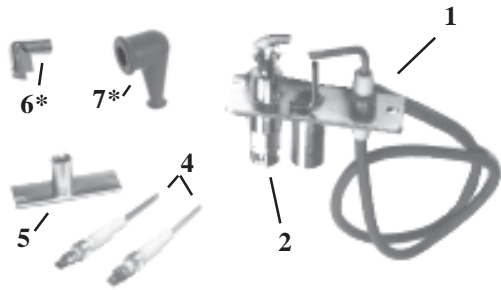

*See Instructions below.

NOTE: Vertical spark pilots for ignition systems other than G60 and G67 are no longer available.

Replacement Pilot Kits		Natural Gas - P/N 110865	Propane Gas - P/N 110866
Code	P/N	Component Description	
1	41775	Natural Gas Pilot Assy with orifice, high tension lead; less pilot tubing, less flame probe, less sensor lead (Baso #J999HHW6221)	
	44673	Propane Gas Pilot Assy with orifice, high tension lead; less pilot tubing, less flame probe, less sensor lead (Baso #J999HHW4209)	
2	44048	Natural Gas Orifice only, #6221	
	37801	Propane Gas Orifice only, #4209	
3	92848	Sensor lead assembly, 16" lg and 21" lg wires (not illustrated)	
4	43594	(2) Flame probe Y75BA-3	
5	44678	Bracket Y59DD-1	
6*	112647	Crimp-on, 90° Rajah terminal connector	
7*	112648	90° Boot Terminal Protector	
8	7671	Pilot tubing 26" lg (not illustrated)	
	9664	Nut with breakaway ferrule (2 required when replacing pilot tubing)	

Instructions for connecting ignitor lead on replacement spark pilots to Model G60 and G67 ignition controllers (applies to Pilot Kits in CODES 451 and 454):



Crimp-on, 90° Rajah Terminal Connector, P/N 112647



Protective Boot, P/N 112648

Effective with replacement pilots purchased 9/91, these parts are required (in the kit or separately) when the replacement pilot is for heater Models listed in CODES 451 and 454 equipped with a Model G60 or G67BG-NG-2 ignition controller. (Note: These parts are not required when the ignition controller is a Model G67BG-5 or G770NGC-4.)

1. Identify the ignitor wire attached to the pilot electrode. Slip the 90° protective boot on to the wire, as illustrated →.
2. On the "open" leg of the 90° crimp-on terminal (P/N 112647), locate a flat, triangular spike tab punched in the metal. With the tip of a small, straight screwdriver, force the spike tab toward the inside of the connector. Straighten the tab to a vertical position.
3. Insert the ignitor wire into that same connector leg (just to the 90° bend) and push the wire onto the protruding spike tab, making sure that the tab penetrates the insulation. (Do not strip the ignitor wire.) Using a crimping tool or pliers, squeeze the sides of the terminal to form a "C" shape. The ignitor wire should now be firmly held by the terminal.

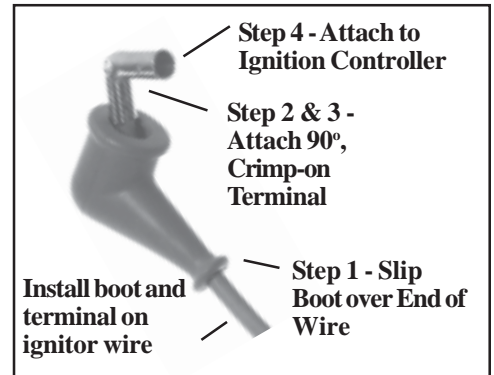

4. Slide the protective boot over the terminal. Holding the boot, attach the 90° Rajah terminal to the ignitor lead Rajah connector on the Model G60 or G67BG/NG-2 ignition controller.

Miscellaneous Parts

Condensate Drain Kit, P/N 31765 (Same as Option CS1)

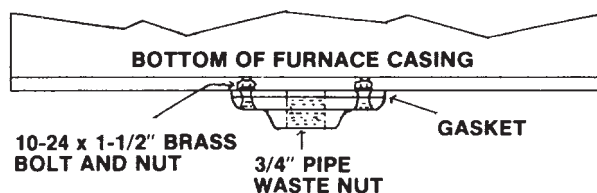

Tawny Beige Touch-Up PAINT

10 oz Spray Can, P/N 37919

1 gallon can, P/N 37708

Tapes for Curb Cap and Roof Curb

P/N 66302, 1/4" x 1-1/4" x 50' for roof curb

P/N 80013, 1/4" x 4" x 50' for curb cap

Evaporative Cooling Module - Model RAM

Code	Component Description	RAM 31		RAM 42		RAM 55
		200	225	250	300	400
500	Cabinet Top Assembly	43044	43044	43047	43047	43050
501	Left Side Panel Assembly	43034	43034	43034	43034	43034
502	Outer Filter Assembly	82575	82575	82585	82585	82593
503	Outer Filter Pad only	82584	82584	82592	82592	82601
		27-3/16x28-3/8		27-3/16x36-5/8		27-3/16x42-1/8
504	Right Side Panel Assembly	43040	43040	43040	43040	43040
505	Bottom Pan Assembly	43025	43025	43030	43030	43032
506	Filter Assembly	(4)82552	(4)82552	(4)82558	(4)82558	(4)82563
507	Media Pad Only Less Frame	(4)82557	(4)82557	(4)82562	(4)82562	(4)82567
		15x32-1/2		19-1/8x32-1/2		24-5/16x32-1/2
508	Nozzle Delavan 1/2 K40 brass	82569	82569	82569	82569	82569
509	Float Valve	42928	42928	42928	42928	42928
510	Switch and Plate	42929	42929	42929	42929	42929
511	Junction box	43028	43028	43028	43028	43028
512	Pump 115V, G500-S-3	80710	80710	80710	80710	80710
513	Pump 208/230V, G-500-S-3	80711	80711	80711	80711	80711
514	Complete Nozzle Kit Less Pump	82568	82568	82572	82572	82573
515	Fill and Drain Kit 115V	50031	50031	50031	50031	50031
	Fill and Drain Kit 208V	50823	50823	50823	50823	50823
	Fill and Drain Kit 230V	50824	50824	50824	50824	50824

NOTES:

Do not confuse RAM units with Model REC which is the currently manufactured evaporative cooling module. For parts for Model REC, see Form RZ-NA 708.

RAM units manufactured prior to 11/83 (Serial No. Code AIK) require ordering filter with frame.

When ordering replacement motor for Little Giant pump, order pump motor support bracket to accommodate the Beckett pump bracket, P/N 80664, for all voltages.

RAM Evaporative Cooling Module - Inlet View

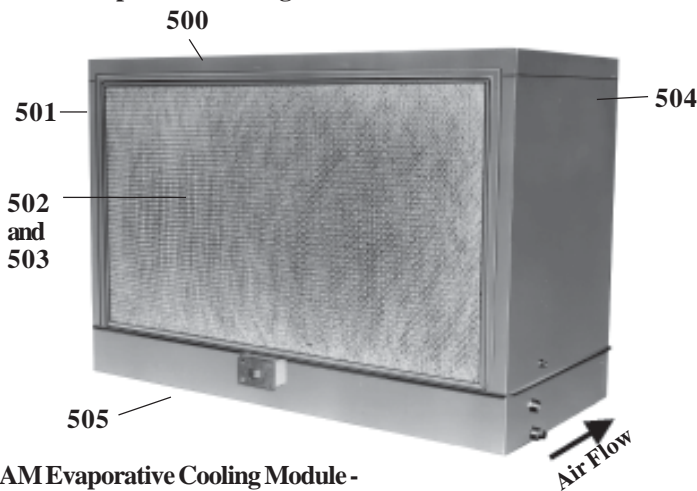

CODE 515, Fill and Drain Kit

CODE 515 — AUTOMATIC FILL AND DRAIN OPTION

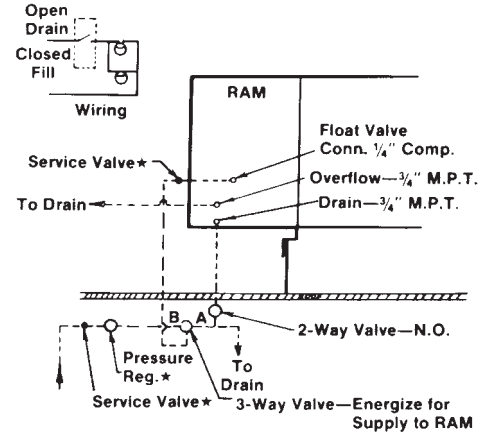

*Supplied by others. Maximum pressure — 10 PSIG.
NOTE: Valve piping must be located inside for protection against freezing.



Fill and Drain Kit Valves

Voltage	2-Way Valve Only	3-Way Valve Only
115V	50032	50033
208V	50297	50296
230V	50299	50298

RAM Evaporative Cooling Module - Inlet View with Outer Filter Assembly Removed

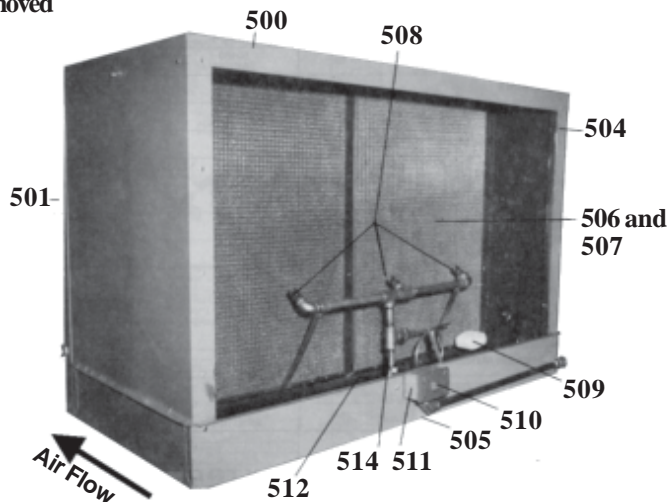

800-695-1901

www.RezSpec.com

©2004 Thomas & Betts Corporation, All rights reserved.
MANUFACTURER OF GAS, OIL, ELECTRIC HEATING AND VENTILATING SYSTEMS

Printed in U.S.A.

Trademark Note: Reznor® is registered in the United States and other countries.

704 OG POD Form RZ-NA-P-X/XE/RX/RPV

Thomas & Betts

Form RZ-NA-P-X/XE/RX/RPV, Page 28