

USER'S INFORMATION MANUAL

UPFLOW/HORIZONTAL & DOWNFLOW TWO STAGE, INDUCED DRAFT GAS FURNACES



Recognize this symbol as an indication of Important Safety Information!

▲ WARNING

If the information in this manual is not followed exactly, a fire or explosion may result, causing property damage, personal injury or loss of life.

▲ FOR YOUR SAFETY

- Do not store or use gasoline or other flammable vapors and liquids, or other combustible materials in the vicinity of this or any other appliance.
- WHAT TO DO IF YOU SMELL GAS
 - Do not try to light any appliance.
 - Do not touch any electrical switch; do not use any phone in your building.
 - Immediately call your gas supplier from a neighbor's phone. Follow the gas supplier's instructions.
 - If you cannot reach your gas supplier, call the fire department.
 - Do not rely on smell alone to detect leaks. Due to various factors, you may not be able to smell fuel gases.
 - A U. L. recognized fuel gas and CO detector(s) are recommended in all applications, and their installation should be in accordance with the manufacturer's recommendations and/or local laws, rules, regulations or codes.
- **Installation and service must be performed by a qualified installer, service agency or the gas supplier.**

IMPORTANT: READ THESE INSTRUCTIONS THOROUGHLY BEFORE ATTEMPTING TO OPERATE THIS FURNACE.

This furnace has been designed to give you many years of efficient, dependable home comfort. With regular maintenance, this furnace will operate satisfactorily year after year. Please read this manual to familiarize yourself with operation, routine maintenance schedule, and safety procedures.

▲ WARNING

DEVICES ATTACHED TO THE FLUE OR VENT FOR THE PURPOSE OF

REDUCING HEAT LOSS UP THE CHIMNEY, INCLUDING FIELD-INSTALLED DRAFT INDUCERS, HAVE NOT BEEN TESTED AND HAVE NOT BEEN INCLUDED IN THE DESIGN CERTIFICATION OF THIS FURNACE. WE, THE MANUFACTURER, CANNOT AND WILL NOT BE RESPONSIBLE FOR INJURY OR DAMAGE CAUSED BY THE USE OF SUCH UNTESTED AND/OR UNCERTIFIED DEVICES, ACCESSORIES OR COMPONENTS.

SAFETY

▲ WARNING

IMPROPER INSTALLATION, ADJUSTMENT, ALTERATION, SERVICE OR MAINTENANCE CAN CAUSE PROPERTY DAMAGE, PERSONAL INJURY OR DEATH. FOR ASSISTANCE OR ADDITIONAL INFORMATION CONSULT A QUALIFIED INSTALLER, SERVICE AGENCY OR THE GAS SUPPLIER.

▲ WARNING

OBSTRUCTION OF THE AIR VENT ON AN LP (PROPANE) TANK REGULATOR CAN CAUSE EXPLOSION OR FIRE RESULTING IN PROPERTY DAMAGE, SEVERE PERSONAL INJURY OR DEATH. YOUR GAS SUPPLIER SHOULD PERIODICALLY INSPECT AND CLEAN THE AIR VENT SCREEN TO PREVENT ANY OBSTRUCTION. KEEP PROTECTIVE REGULATOR COVER IN PLACE, AS EXPOSURE TO THE ELEMENTS CAN CAUSE ICE BUILDUP AND REGULATOR FAILURE.

CAREFULLY FOLLOW THESE SAFETY RULES:

1. Do not place combustible material on or against the furnace jacket. Keep the area around the furnace clear and free of all combustible materials including gasoline and other flammable vapors and liquids.
2. A furnace installed in an attic or other insulated space must be kept free and clear of insulating material. Examine the furnace area when installing the furnace or adding more insulation. Some materials may be combustible.
3. To prevent carbon monoxide poisoning, replace all blower doors and compartment covers after the furnace is serviced. Do not operate the unit without all panels and doors securely in place.
4. Should overheating occur, or the gas valve fail to shut off the gas supply, turn off the manual gas valve to the furnace before turning off the electrical supply.
5. Any additions, changes or conversions required in order for the furnace to satisfactorily meet the application needs should be made by a qualified installer, service agency or the gas supplier, using factory specified or approved parts. Read your WARRANTY. Contact the WARRANTOR for conversion information. This furnace was equipped at the factory for use on NATURAL GAS ONLY. Conversion to L.P. GAS requires a special kit supplied by the WARRANTOR.
6. A furnace needs an adequate supply of combustion and ventilation air for proper and safe operation. Do not block or obstruct air openings on the furnace or air openings supplying the area where

DO NOT DESTROY. PLEASE READ CAREFULLY AND KEEP IN A SAFE PLACE FOR FUTURE REFERENCE.

the furnace is installed. Do not store anything around the furnace that could block the flow of fresh air to the unit. Your installation may receive air from the inside heated space., from the outside, from the

attic or crawl space. Whenever adding insulation, be sure the air supply openings are not covered.

7. Do not use this furnace if any part has been under water. Immediately

call a qualified installer, service agency or the gas supplier to inspect the furnace and to replace any part of the control system and any gas control which has been under water.

SYSTEM OPERATION INFORMATION

1. Keep the air filters clean. Your heating system will operate more efficiently and provide better heating, more economically.
2. Arrange your furniture and drapes so that the supply air registers and the return air grilles are unobstructed.
3. Close doors and windows. This will reduce the heating load on your system.
4. Avoid excessive use of kitchen exhaust fans.
5. Do not permit the heat generated by television, lamps, or radios to influence the thermostat operation.
6. If you desire to operate your system with constant air circulation, please ask advice from a qualified installer, service agency or the gas supplier.

During the heating season the operation of the warm air furnace is automatic. Your qualified installer, service agency or the gas supplier has provided a wall mounted thermostat which is sensitive to the change in temperature of the air moving around the thermostat. Your thermostat will have switches to select some or all of the following functions:

HEAT - Turns heating on when temperature drops below the desired temperature.

COOL - Turns cooling on when temperature rises above the desired temperature.

AUTO - Turns cooling or heating on as required to maintain the desired temperature.

OFF - Turns heating and cooling modes off. (The blower may still run in the FAN-ON position.)

FAN-ON - Turns the blower on for continuous operation.

FAN-AUTO - The blower cycles on and off with cooling or heating operation.

Figure 1. Burner Compartment, showing location of Gas Controls

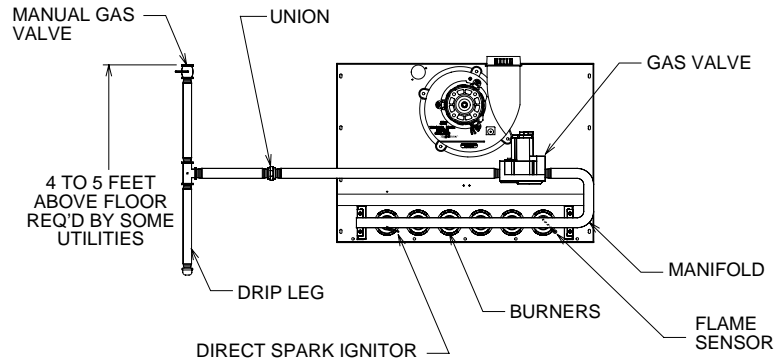

STA-0764-01

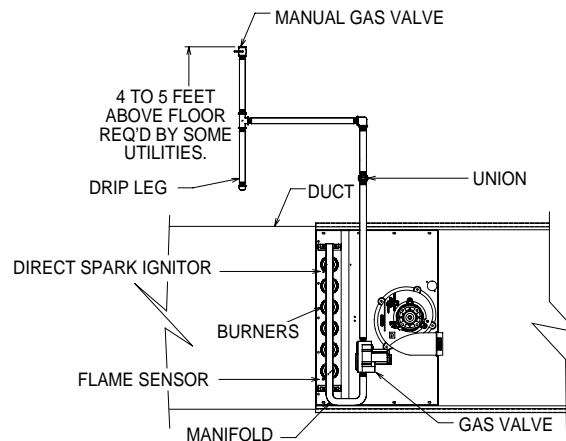

ST-A0763-01

FOR YOUR SAFETY READ BEFORE OPERATING

▲ WARNING

IF YOU DO NOT FOLLOW THESE INSTRUCTIONS EXACTLY, A FIRE OR EXPLOSION MAY RESULT CAUSING PROPERTY DAMAGE, PERSONAL INJURY OR LOSS OF LIFE.

NOTE: Read and follow the Safety Information, Operating Instructions and Instructions To Turn Off Gas To Appliance located on the furnace. This label will have specific information regarding the furnace and its gas controls.

TYPICAL GAS CONTROL VALVE

ELECTRIC IGNITION

The gas control lever or knob has "ON" and "OFF" positions only (see Figure 2). This furnace is equipped with an ignition device which automatically lights the burners. Do **not** try to light the burners by hand.

B. BEFORE OPERATING smell all around the appliance area for gas. Be sure to smell next to the floor because

some gas is heavier than air and will settle on the floor.

WHAT TO DO IF YOU SMELL GAS

- Do not try to light any appliance
- Do not touch any electric switch; do not use any phone in your building.
- Immediately call your gas supplier from a neighbor's phone. Follow the gas supplier's instructions.
- If you cannot reach your gas supplier, call the fire department.

OPERATING INSTRUCTIONS (DIRECT SPARK IGNITION SYSTEM)

1. STOP! Read all safety information.
2. Set the thermostat to the lowest setting.

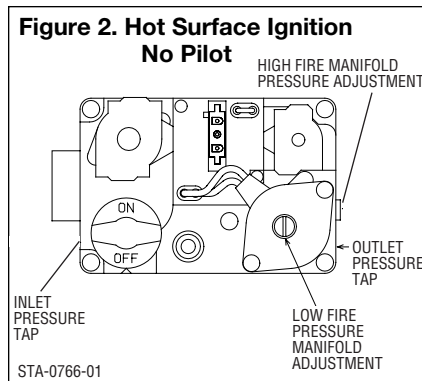

3. Turn off all electric power to the appliance.
4. This appliance does not have a pilot burner. It is equipped with an ignition device which automatically lights the burner. Do not try to light the burner by hand.
5. Remove control door.
6. Turn the gas control knob clockwise to "OFF" position.
7. Wait five (5) minutes to clear out any gas. If you then smell gas, STOP! Follow 'B' in the safety information above. If you don't smell gas, go to the next step.
8. Turn on the gas to the main burners by turning the gas control knob counterclockwise to the "ON" position.
9. Replace the control door.
10. Turn on all electric power to the appliance.
11. Set the thermostat to the desired setting.
12. If the appliance will not operate, follow the instructions "To Turn Off Gas To The Appliance" and call your qualified installer, service agency or the gas supplier.

TO TURN OFF GAS TO THE APPLIANCE

1. Set the thermostat to the lowest setting.
2. Turn off all electric power to the appliance if service is to be performed.
3. Remove the control door.

4. Turn the gas control knob to the "OFF" position, or depress the gas control lever and move to the "OFF" position.
5. Replace the control door.

SEQUENCE OF OPERATION

Single Stage Thermostat

1. When there is a call for heat the furnace runs a self check routine to verify that the contacts on the pressure switches are open. The limit switches are constantly monitored.
2. The induced draft motor starts on high for a few seconds to assure that the low pressure switch closes and then changes to low speed. It will continue to run for a thirty second prepurge.
3. The spark ignitor is energized and the low stage of the gas valve opens, lighting the burners.
4. After the gas valve opens, the remote sensor must prove ignition for one second.
5. The main blower starts on low speed 30 seconds after the gas valve opens. The furnace will operate on low fire for 12 minutes and then, if the thermostat is not satisfied, shift to high fire. This will cause the draft inducer to go to high speed and the main blower will go to heat speed. The induced draft motor will continue running for a 5 second (low speed) or 10 second (high speed) post purge. The main blower will run for 90 seconds on high speed or 120 seconds on low speed.

Sequence if system doesn't light or sense flame

1. If flame is not sensed within 8 seconds after the gas valve opens, the valve closes and the ignitor is de-energized.
2. The induced draft motor will run for 60 seconds on low, stop momentarily, and then restart.
3. The ignition process will go through one more try on low fire. If this fails, there will be two tries on high fire with a 30 second interpurge between trials. If there is no ignition after the 2nd trial on high fire, the furnace will go into soft lockout for one hour.
4. The sequence will repeat after a one hour delay and continue repeating until ignition is successful or the call for heat is terminated.

5. To reset the lockout, make and break power either at the thermostat or at the unit disconnect switch for 5 to 10 seconds. The furnace will then go through another set of trials for ignition.

Two Stage Thermostat

Connect W1 and W2 terminals on the thermostat to W and W2 terminals on the control board.

Call for 1st stage heat

1. When there is a call for heat the furnace runs a self check routine to verify that the contacts on the pressure switches are open. The limit switches are constantly monitored.
2. The induced draft motor starts on high for a few seconds to assure that the low pressure switch closes and then changes to low speed. It will continue to run for a thirty second prepurge.
3. The spark ignitor is energized and the low stage of the gas valve opens, lighting the burners.
4. After the gas valve opens the remote flame sensor must prove ignition for one second.
5. The main blower will start on low speed 30 seconds after the gas valve opens. The furnace will continue to operate on low fire until the call for heat is satisfied or the second stage contacts close.
6. If the 1st stage call for heat is satisfied the gas valve will close and the induced draft motor will continue running for a 10 second post purge. The main blower will run for 90 seconds.

Call for 2nd stage heat after 1st stage

1. R and W2 thermostat contacts close, calling for 2 stage heat.
2. The induced draft motor then switches to high speed and the high pressure switch contacts will close, allowing the gas valve to switch to high fire and the main blower to switch to heating speed.

2nd stage heat satisfied, 1st stage heat still required.

1. R and W2 thermostat contacts open.
2. The induced draft motor switches to low fire and the main blower motor switches to low speed. The furnace will continue to run in this mode until the 1st stage heat call is satisfied. The system will shut down as noted in "c," under 1st stage call for heat.

Figure 3. Upflow Filter Location

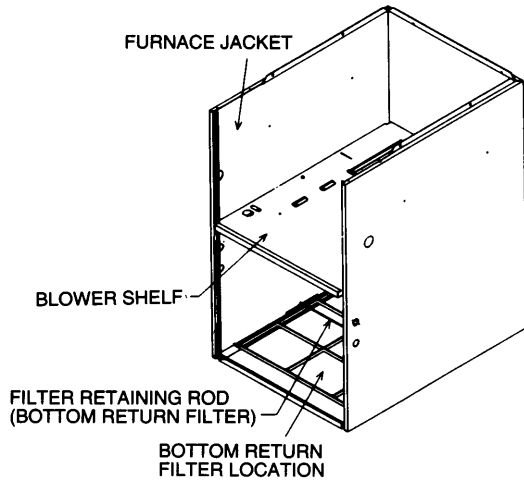

UPFLOW FILTER SIZES

FURNACE WIDTH	INPUT BTUH (K's)	SIZE		QTY.
		BOTTOM	SIDE	
14"	50	12 1/4" x 25"	15 3/4" x 25"	1
17 1/2"	75 & 100	15 3/4" x 25"	15 3/4" x 25"	1
21"	100	19 1/4" x 25"	15 3/4" x 25"	1
24 1/2"	125 & 150	22 3/4" x 25"	15 3/4" x 25"	1

Figure 4. Upflow Side Filter Installation

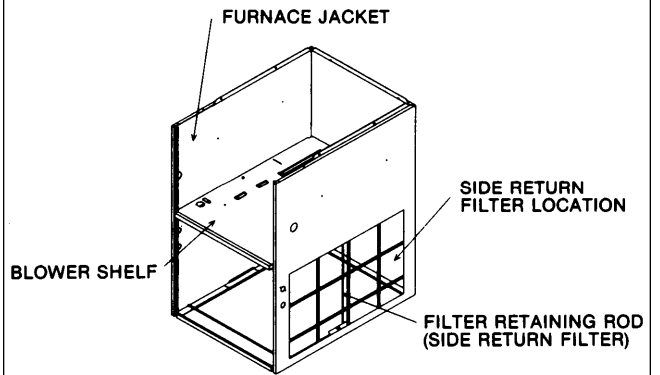
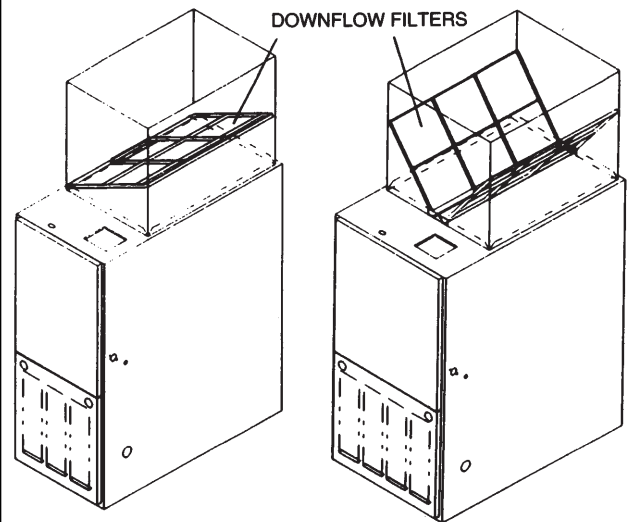

Figure 5. Downflow Filters Installation



DOWNFLOW FILTER SIZES

FURNACE WIDTH	INPUT BTUH (K)	SIZE	QTY.
14"	50	14" x 20"	1
17 1/2"	75 & 100	12" x 20"	2
21"	100	12" x 20"	2
24 1/2"	125 & 150	14" x 20"	2

MAINTENANCE

▲ WARNING

DISCONNECT MAIN ELECTRICAL POWER TO THE UNIT BEFORE ATTEMPTING ANY MAINTENANCE. FAILURE TO DO SO CAN CAUSE ELECTRICAL SHOCK RESULTING IN SEVERE PERSONAL INJURY OR DEATH.

▲ CAUTION

DO NOT OPERATE YOUR SYSTEM FOR EXTENDED PERIODS WITHOUT FILTERS. A PORTION OF THE DUST ENTRAINED IN THE AIR MAY TEMPORARILY LODGE IN THE AIR DUCT RUNS AND AT THE SUPPLY REGISTERS. ANY RECIRCULATED DUST PARTICLES WILL BE HEATED AND CHARRED BY CONTACT WITH THE FURNACE HEAT EXCHANGER. THIS RESIDUE WILL SOIL CEILINGS, WALLS, DRAPES, CARPETS, AND OTHER HOUSEHOLD ARTICLES.

IT IS RECOMMENDED THAT AN ANNUAL INSPECTION OF YOUR FURNACE BE DONE BY A QUALIFIED INSTALLER, SERVICE AGENCY OR THE GAS SUPPLIER.

FILTER MAINTENANCE

Have your qualified installer, service agency or the gas supplier instruct you on how to access your filters for regular maintenance.

▲ WARNING

TURN OFF ELECTRICAL POWER TO FURNACE BEFORE REMOVING FRONT ACCESS DOOR. FAILURE TO DO SO CAN RESULT IN ELECTRICAL SHOCK, SEVERE PERSONAL INJURY OR DEATH.

Keep air filters clean at all times. Vacuum dirt from filter, wash with detergent and water, air dry thoroughly and reinstall.

REMOVING FILTERS

UPFLOW FURNACE - FILTER IN BOTTOM LOCATION

1. Remove the blower compartment access door.
2. Disengage the filter retaining rod and pull filter out.
3. Clean filter and reinstall.

After filters are cleaned and returned to the furnace, be sure doors are properly reinstalled. If you are not totally sure of this procedure, consult a qualified installer, service agency or the gas supplier.

DOWNFLOW FURNACE - FILTERS IN TOP DUCT LOCATION

1. Remove the blower compartment access door.
2. Push up and in on the filters to disengage from retaining bracket and pull filters out.
3. Clean filter(s) and reinstall.

ROUTINE MAINTENANCE

Routine maintenance to be provided by a qualified installer, service agency or the gas supplier ONLY.

LUBRICATION

The blower motor and induced draft motor are permanently lubricated by the manufacturer and do not require further attention.

▲ WARNING

DISCONNECT MAIN ELECTRICAL POWER TO THE UNIT BEFORE ATTEMPTING ANY MAINTENANCE. FAILURE TO DO SO CAN RESULT IN ELECTRICAL SHOCK, SEVERE PERSONAL INJURY OR DEATH.

The blower compartment and motor should be inspected and cleaned periodically by your qualified installer, service agency or the gas supplier to prevent the possibility of overheating due to an accumulation of dust and dirt on the windings or on the motor exterior. And, as suggested elsewhere in these instructions, keep the air filters clean because dirty filters can restrict airflow and the motor depends upon sufficient air flowing across and through it to keep from overheating

COMBUSTION AREA AND VENT SYSTEM

1. It is recommended that an annual inspection of your furnace be done by a qualified installer, service agency or the gas supplier.
2. Turn OFF the electrical supply to the furnace and remove the access doors.
3. Inspect the gas burners for dirt, rust, or scale.

▲ WARNING

IF DIRT, RUST, SOOT OR SCALE ACCUMULATIONS ARE PRESENT, DO NOT OPERATE THE FURNACE. INSPECT THE HEAT EXCHANGERS FOR LEAKS. LEAKS CAN CAUSE TOXIC FUMES TO ENTER THE HOME RESULTING IN CARBON MONOXIDE POISONING OR DEATH.

4. Inspect the the flue connection area and vent pipe. Be sure that the vent connector is in place and slopes upward and is physically sound, without holes or excessive corrosion.

▲ WARNING

IF HOLES ARE FOUND IN THE VENT PIPE, OR IF IT HAS BECOME DISCONNECTED, TOXIC FUMES CAN ESCAPE INTO THE HOME RESULTING IN CARBON MONOXIDE POISONING OR DEATH. DO NOT OPERATE THIS FURNACE. APPROPRIATE SERVICE MUST BE APPLIED.

5. Be sure that the return air duct connections are physically sound, are sealed to the furnace casing and terminate outside the space containing the furnace.
6. Be sure the physical support of the furnace is sound, without sags, cracks, etc., around the base so as to provide a seal between the support and the base.
7. Look for obvious signs of deterioration of the furnace.
8. If the furnace is free of the above conditions, replace the access doors and restore electrical power to the furnace.
9. Start the furnace and observe its operation. Watch the burner flames to see if they are bright blue. If a suspected malfunction is observed, or the burner flames are not bright blue, apply appropriate service.

MARKINGS

It is recommended that an annual inspection and cleaning of all furnace markings be made to assure legibility. Attach a replacement marking, which can be obtained through the distributor, if any are found to be illegible or missing.

