

Installation Operation Maintenance

Packaged Gas/Electric

YC*150D***B*, YCD151C***B*, YCH151C***C*, YC*155B***H*,
YC*175C***E*, YC*180B***H*, YC*181C***C*, YC*200B***J*,
YC*210C***E*, YC*211C***C*, YC*240B***J*, YC*241C***C*,
YC*300B***H*, YC*301C***C*

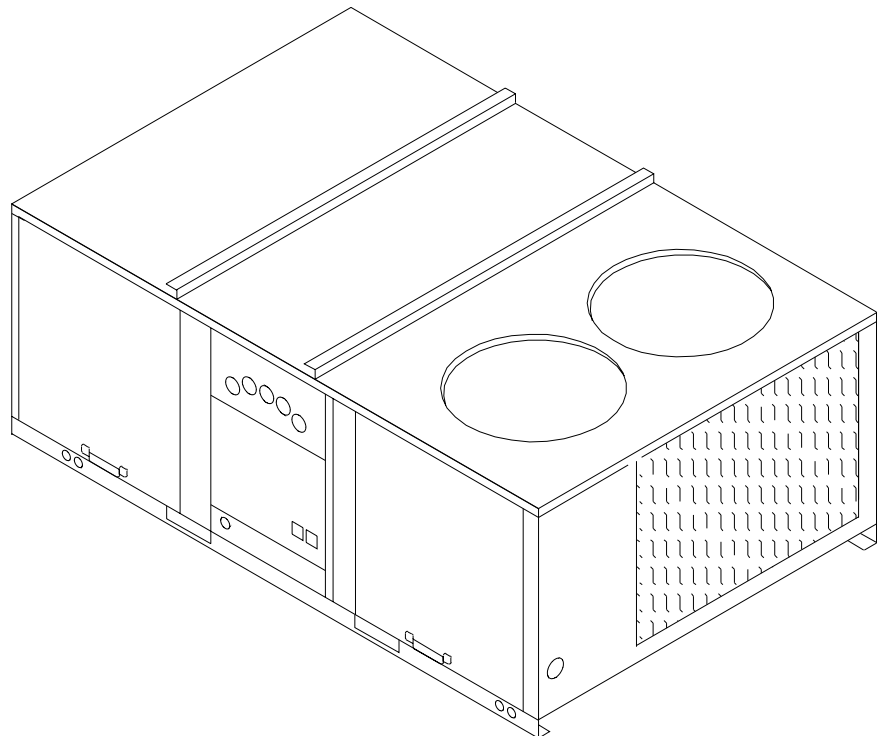

Contents

General Information

Model Description	3
Literature Change History	4
Overview of Manual	4
Hazard Identification	5
Unit Nameplate	5
Compressor Nameplate	5
Unit Description	5
Economizer Control Actuator	6
ReliaTel™ Control	6
ReliaTel™ Trane Communication Interface	6
RLCI - ReliaTel™ LonTalk Communica- tion Interface (Optional)	6
RTOM – ReliaTel™ Options Module (Optional)	6
System Input Devices & Functions ..	6
Supply Fan Failure Input (Optional) ..	6
Clogged Filter Switch (Optional)	6
Relative Humidity Sensor (Optional) ..	6
Compressor Disable (CPR1/2)	6
Low Pressure Control	7
High Pressure Control (Optional)	7
Power Exhaust Control (Optional)	7
Lead/Lag Control (Dual Circuit Only) ..	7
(BAYSENS006B)	7
(BAYSENS008B)	7
(BAYSENS010B)	7
BAYSENS019B	7
(BAYSENS013B)	7
(BAYSENS014B)	7
(BAYSENS016A)	7
(BAYSENS017B)	8
BAYSENS025A Remote sensor for BAYSTAT036A, 037A.	8
High Temperature Sensor (BAYFRST001A)	8
Evaporator Frost Control	8
Smoke Detector Sensor (Optional) ..	8
Unit Inspection	9
Precautionary Measures	9
Storage	9

Unit Dimensions

Installation Clearances	10
Unit/Curb Dimensions	11
Unit/Curb Dimensions	12
Horizontal Duct Dimensions	13

Unit Weight / Rigging

Rigging and Center-of-Gravity Data ..	14
---------------------------------------	----

Installation

Foundation	15
Ductwork	15
General Unit Requirements	16
Factory Installed Economizer	16
Electric Heat Requirements	16
Condensate Drain Configuration ..	16
Condensate Trap Installation	16
Filter Installation	16
Main Unit Power	17
Standard Wiring	17
Optional TBUE Wiring	18
Field Installed Control Wiring	18
Control Power Transformer	18
Controls using 24 VAC	18
24V AC Conductors with Reliatel ..	18
Controls using DC Analog Input/Outputs	19
DC Conductors	19
Reliatel Conventional Thermostat Field Wiring Diagrams	19
Reliatel Refrigeration Module	19
Smoke Detector	20
Customer Low Voltage Wiring-	21
Space Temperature Averaging	22
Temperature vs. Resistance	22
Voltage Imbalance	24
Electrical Phasing	24
Crankcase Heaters (Optional)	25

Pre - Start

Test Modes	26
Verifying Proper Air Flow	27

Start Up

Economizer Start-Up	28
Compressor Start-Up	28
Scroll Compressors	28
Heating Start-Up	29

Final System Set Up

Final System Setup	30
--------------------------	----

Maintenance

Fan Belt Adjustment	31
Filters	32
Return Air Smoke Detector Maintenance	32
Cooling Season	32
Heating Season	32
Final Process	33
Sample Maintenance Log	34

Trouble Shooting

ReliaTel Control	35
System Status Checkout Procedure	35
System Failure	36
Cooling Failure	36
Service Failure	36
Simultaneous Heat and Cool Failure	36
Cool Failure	36
Resetting Cooling and Heating Lockouts	36
(ZTS) Service Indicator	37
Fan Failure Switch	37
(ZTS) Test	37
(ZTEMP)	37
Cooling Set Point (CSP) and Heating Set Point (HSP)	37
Testing serial communication voltage	38
ReliaTel Refrigeration Module (RTRM) Default Chart	38
Unit Economizer Control (ECA) Troubleshooting	38
ReliaTel Control	38

Model Number Description

Packaged Gas/Electric Unit Typical Model Nomenclature

<u>Y</u>	<u>C</u>	<u>D</u>	<u>1</u>	<u>5</u>	<u>0</u>	<u>C</u>	<u>3</u>	<u>L</u>	<u>0</u>	<u>A</u>	<u>A</u>
1	2	3	4	5	6	7	8	9	10	11	12

Digits 1, 2 - Product Type

YC = Packaged Gas/Electric

Digit 3 - Airflow Configuration

D = Downflow
H = Horizontal

Digits 4, 5, 6 - Nominal Gross Cooling Capacity (MBh)

150	=	12½ Ton Standard Efficiency
151	=	12½ Ton High Efficiency
180	=	15 Ton Standard Efficiency
181	=	15 Ton High Efficiency
210	=	17½ Ton Standard Efficiency
211	=	17½ Ton High Efficiency
240	=	20 Ton Standard Efficiency
241	=	20 Ton High Efficiency
300	=	25 Ton Standard Efficiency
301	=	25 Ton High Efficiency

Digit 11 - Minor Design Sequence

Digit 12 - Service Digit

Digit 7 - Major Development Sequence

Digit 8 - Electrical Characteristics

3 = 208-230/60/3
4 = 460/60/3
W = 575/60/3

Digit 9 - Heating Capacity

L = Low Heat
M = Medium Heat
H = High Heat

Digit 10 - Factory-Installed Options

A = Factory-installed Economizer
B = Oversized Motor
C = Downflow Economizer and Oversized Motor
F = Trane Communications Interface (TCI)
G = Downflow Economizer and TCI
H = TXV/Face-Split Evaporator
J = Oversized Motor and TXV/Face-Split Evaporator
K = Downflow Economizer, Oversized Motor, and TXV/Face-Split Evaporator
L = Downflow Economizer with TXV/Face-Split Evaporator
M = Reheat Coil
N = Downflow Economizer and Reheat Coil
P = Oversized Motor and Reheat Coil
R = Downflow Economizer, Oversized Motor and Reheat Coil

General Information

Literature Change History

YC-IOM-13 (December 2004)
Added Dehumidification Option information.

YC-IOM-13 (April 2003)
Reliatel Control System implemented

Overview of Manual

Note: One copy of this document ships inside the control panel of each unit and is customer property. It must be retained by the unit's maintenance personnel.

This booklet describes proper installation, operation, and maintenance procedures for air cooled systems. By carefully reviewing the information within this manual and following the instructions, the risk of improper operation and/or component damage will be minimized.

It is important that periodic maintenance be performed to help assure trouble free operation. A maintenance schedule is provided at the end of this manual. Should equipment failure occur, contact a qualified service organization with

qualified, experienced HVAC technicians to properly diagnose and repair this equipment.

Hazard Identification

Warnings and Cautions appear at appropriate sections throughout this manual. Read these carefully.

 **WARNING** – Indicates a potentially hazardous situation which, if not avoided, could result in death or serious injury.

 **CAUTION** – Indicates a potentially hazardous situation which, if not avoided, may result in minor or moderate injury. It may also be used to alert against unsafe practices.

CAUTION – Indicates a situation that may result in equipment or property-damage-only accidents.

Model Number Description

All products are identified by a multiple-character model number that precisely identifies a particular type of unit. An explanation of the alphanumeric identification code is provided below. Its use will enable the owner/operator, installing contractors, and service engineers to define the operation, specific components, and other options for any specific unit.

When ordering replacement parts or requesting service, be sure to refer to the specific model number and serial number printed on the unit nameplate.

General Information

WARNING

Contains Refrigerant!

System contains oil and refrigerant under high pressure. Recover refrigerant to relieve pressure before opening the system. See unit nameplate for refrigerant type. Do not use non-approved refrigerants, refrigerant substitutes, or refrigerant additives.

Failure to follow proper procedures or the use of non-approved refrigerants, refrigerant substitutes, or refrigerant additives could result in death or serious injury or equipment damage.

WARNING

Hazardous Voltage w/Capacitors!

Disconnect all electric power, including remote disconnects and discharge all motor start/run capacitors before servicing. Follow proper lockout/tagout procedures to ensure the power cannot be inadvertently energized. Verify with an appropriate voltmeter that all capacitors have discharged. Failure to disconnect power and discharge capacitors before servicing could result in death or serious injury.

Note: For additional information regarding the safe discharge of capacitors, see *PROD-SVB06A-EN* or *PROD-SVB06A-FR*

CAUTION

Equipment Damage From Ultraviolet (UV) Lights!

The manufacturer does not recommend field installation of ultraviolet lights in its equipment for the intended purpose of improving indoor air quality. High intensity C-band ultraviolet light is known to severely damage polymer (plastic) materials and poses a personal safety risk to anyone exposed to the light without proper personal protective equipment. Polymer materials commonly found in HVAC equipment that may be susceptible include insulation on electrical wiring, fan belts, thermal insulation, various fasteners and bushings. Degradation of these materials can result in serious damage to the equipment.

The manufacturer accepts no responsibility for the performance or operation of our equipment in which ultraviolet devices were installed outside of the manufacturer's factory or its approved suppliers.

Unit Nameplate

A Mylar unit nameplate is located on the unit's corner support next to the filter access panel. It includes the unit model number, serial number, electrical characteristics, refrigerant charge, as well as other pertinent unit data.

Compressor Nameplate

The nameplate for the compressors are located on the side of the compressor.

Unit Description

Before shipment, each unit is leak tested, dehydrated, charged with refrigerant and compressor oil, and run tested for proper control operation.

The condenser coils are aluminum fin, mechanically bonded to copper tubing.

Direct-drive, vertical discharge condenser fans are provided with built-in thermal overload protection.

The ReliaTel™ Control Module is a microelectronic control system that is referred to as "Refrigeration Module" (RTRM). The acronym RTRM is used extensively throughout this document when referring to the control system network.

This module through Proportional/Integral control algorithms perform specific unit functions that governs unit operation in response to; zone temperature, supply air temperature, and/or humidity conditions depending on the application. The stages of capacity control for these units are achieved by starting and stopping the compressors.

The RTRM is mounted in the control panel and is factory wired to the respective internal components. The RTRM receives and interprets information from other unit modules, sensors, remote panels, and customer binary contacts to satisfy the applicable request for cooling.

General Information

Economizer Control Actuator ReliaTel™ Control

The ECA monitors the mixed air temperature, return air temperature, minimum position setpoint (local or remote), power exhaust setpoint, CO2 setpoint, CO2, and ambient dry bulb/enthalpy sensor or comparative humidity (return air humidity against ambient humidity) sensors, if selected, to control dampers to an accuracy of +/- 5% of stroke. The actuator is spring returned to the closed position any time that power is lost to the unit. It is capable of delivering up to 25 inch pounds of torque and is powered by 24 VAC.

RTCI -- ReliaTel™ Trane Communication Interface (Optional)

This module is used when the application calls for an ICS™ building management type control system. It allows the control and monitoring of the system through an ICS panel. The module can be ordered from the factory or ordered as a kit to be field installed. Follow the installation instruction that ships with each kit when field installation is necessary.

RLCI - ReliaTel™ LonTalk Communication Interface (Optional)

This module is used when the application calls for an ICS™ building management type control system that is LonTalk. It allows the control and monitoring of the system through an ICS panel. The module can be ordered from the factory or ordered as a kit to be field installed. Follow the installation instruction that ships with each kit when field installation is necessary.

RTOM – ReliaTel™ Options Module (Optional)

The RTOM monitors the supply fan proving, clogged filter, supply air temperature, exhaust fan setpoint, supply air tempering, Froststat™ and smoke detector. Refer to system input devices and functions for operation.

System Input Devices & Functions

The RTRM must have a zone sensor or thermostat input in order to operate the unit. The flexibility of having several mode capabilities depends upon the type of zone sensor or thermostat selected to interface with the RTRM.

The descriptions of the following basic Input Devices used within the RTRM network are to acquaint the operator with their function as they interface with the various modules. Refer to the unit's electrical schematic for the specific module connections.

The following controls are available from the factory for field installation.

Supply Fan Failure Input (Optional)

The Fan Failure Switch can be connected to sense indoor fan operation:

FFS (Fan Failure Switch) If air flow through the unit is not proven by the differential pressure switch connected to the RTOM (factory set point 0.07 " w.c.) within 40 seconds nominally, the RTRM will shut off all mechanical operations, lock the system out, send a diagnostic to ICS, and the SERVICE output will flash. The system will remain locked out until a reset is initiated either manually or through ICS.

Wall Mounted Relative Humidity Sensor (BAYSENS036A)

Field installed, wall mounted humidity sensor is used to control activation of the hot gas reheat dehumidification option. Humidity set points can be selected for relative humidity levels between 40% and 60% by adjusting the DEHUMID setting on the ReliaTel Options Module. See page 19.

Duct Mounted Relative Humidity Sensor (BAYSENS037A)

Field installed, duct mounted humidity sensor is used to control activation of the hot gas reheat dehumidification option. Humidity set points can be selected for relative humidity levels between 40% and 60% by adjusting the DEHUMID setting on the ReliaTel Options Module. See page 19.

Clogged Filter Switch (Optional)

The unit mounted clogged filter switch monitors the pressure differential across the return air filters. It is mounted in the filter section and is connected to the RTOM. A diagnostic SERVICE signal is sent to the remote panel if the pressure differential across the filters is at least 0.5" w.c. The contacts will automatically open when the pressure differential across the filters decreases to approximately 0.4" w.c. The clogged filter output is energized when the supply fan is operating and the clogged filter switch has been closed for at least 2 minutes. The system will continue to operate regardless of the status of the filter switch.

Compressor Disable (CPR1/2)

This input incorporates the low pressure control (LPC) of each refrigeration circuit and can be activated by opening a field supplied contact installed on the LTB.

If this circuit is open before the compressor is started, the compressor will not be allowed to operate. Anytime this circuit is opened for 1 continuous second during compressor operation, the compressor for that circuit is immediately turned "Off". The compressor will not be allowed to restart for a minimum of 3 minutes should the contacts close.

If four consecutive open conditions occur during the first three minutes of operation, the compressor for that circuit will be locked out, a diagnostic communicated to the remote panel (if installed), and a manual reset will be required to restart the compressor.

General Information

Low Pressure Control

ReliaTel Control

When the LPC is opened for 1 continuous second, the compressor for that circuit is turned off immediately. The compressor will not be allowed to restart for a minimum of 3 minutes.

If four consecutive open conditions occur during the first three minutes of operation, the compressor will be locked out, a diagnostic communicated to ICS™ if applicable, and a manual reset will be required to restart the compressor.

High Pressure Control (Optional)

ReliaTel Control

The high pressure controls are wired in series between the compressor outputs on the RTRM and the compressor contactor coils. If the high pressure control switch opens, the RTRM senses a lack of current while calling for cooling and locks the compressor out.

On dual circuit units, if the high pressure control opens, the compressor on the affected circuit is locked out. A manual reset for the affected circuit is required.

Power Exhaust Control (Optional)

The power exhaust fan is started whenever the position of the economizer dampers meets or exceed the power exhaust setpoint when the indoor fan is on.

The setpoint panel is located in the return air section and is factory set at 25%.

Lead/Lag Control (Dual Circuit Only)

Lead/Lag is a selectable input located on the RTRM. The RTRM is configured from the factory with the Lead/Lag control disabled. To activate the Lead/Lag function, simply cut the wire connected to J3-8 at the RTRM. When it is activated, each time the designated lead compressor is shut off due to the load being satisfied, the lead compressor or refrigeration circuit switches. When the RTRM is powered up, i.e. after a power failure, the control will default to the number one circuit compressor.

Zone Sensor Module (ZSM) (BAYSENS006B)

This electronic sensor features three system switch settings (Heat, Cool, and Off) and two fan settings (On and Auto). It is a manual changeover control with single setpoint. (Cooling Setpoint Only)

Zone Sensor Module (ZSM) (BAYSENS008B)

This electronic sensor features four system switch settings (Heat, Cool, Auto, and Off) and two fan settings (On and Auto). It is a manual or auto changeover control with dual setpoint capability. It can be used with a remote zone temperature sensor BAYSENS017B.

Zone Sensor (BAYSENS010B)

This electronic sensor features four system switch settings (Heat, Cool, Auto, and Off) and two fan settings (On and Auto) with four system status LED's. It is a manual or auto changeover control with dual setpoint capability. It can be used with a remote zone temperature sensor BAYSENS017B.

Programmable Zone Sensor - BAYSENS019B

This 7 day programmable sensor features 2, 3 or 4 periods for Occupied or Unoccupied programming per day. If the power is interrupted, the program is retained in permanent memory. If power is off for an extended period of time, only the clock and day may have to be reset.

The Zone Sensor allows selection of 2, 3 or 4 system modes (Heat, Cool, Auto, and Off), two fan modes (On and Auto). It has dual temperature selection with programmable start time capability.

The occupied cooling set point ranges between 45 and 98 degrees Fahrenheit. The heating set point ranges between 43 and 96 degrees Fahrenheit.

A liquid crystal display (LCD) displays zone temperature, temperature set points, day of the week, time, and operational mode symbols.

The Option Menu is used to enable or disable applicable functions, i.e.; Morning Warm-up, Economizer minimum position override during unoccupied status, Fahrenheit or Centigrade, Supply air tempering, Remote zone temperature sensor, 12/24 hour time display, Smart fan, and Computed recovery.

Remote Zone Sensor (BAYSENS013B)

This electronic sensor features remote zone sensing and timed override with override cancellation. It is used with a Trane Integrated Comfort™ building management system.

Remote Zone Sensor (BAYSENS014B)

This electronic sensor features single setpoint capability and timed override with override cancellation. It is used with a Trane Integrated Comfort™ building management system.

General Information

Remote Zone Sensor (BAYSENS016A)

This bullet type temperature sensor can be used for; outside air (ambient) sensing, return air temperature sensing, supply air temperature sensing, remote temperature sensing (uncovered). Wiring procedures vary according to the particular application and equipment involved. Refer to the unit's wiring diagrams for proper connections.

Remote Zone Sensor (BAYSENS017B)

This electronic sensor can be used with BAYSENS006B, 008B, 010B, 019B Remote Panels. When this sensor is wired to a BAYSENS019B Remote Panel, wiring must be 18 AWG Shielded Twisted Pair (Belden 8760 or equivalent). Refer to the specific Remote Panel for wiring details.

BAYSTAT036A

Single Stage - 1 Heat/1 Cool

BAYSTAT037A

Multi Stage - 2 Heat/2 Cool - Can be Used for Economizer Operation

BAYSENS025A Remote sensor for BAYSTAT036A, 037A.

High Temperature Sensor (BAYFRST003A)

This sensor connects to the RTRM Emergency Stop Input on the LTB and provides high limit "shutdown" of the unit. The sensor is used to detect high temperatures due to fire in the air conditioning or ventilation ducts. The sensor is designed to mount directly to the sheet metal duct. Each kit contains two sensors. The return air duct sensor (X1310004001) is set to open at 135°F. The supply air duct sensor (X1310004002) is set to open at 240°F. The control can be reset after the temperature has been lowered approximately 25°F below the cutout setpoint.

Evaporator Frost Control

This input incorporates the Frostat™ control (FOS) mounted in the indoor coil and can be activated by closing a field supplied contact installed in parallel with the FOS.

If this circuit is open before the compressor is started, the compressor will not be allowed to operate. Anytime this circuit is opened for 5 continuous seconds during compressor operation, the compressor for that circuit is immediately turned "Off". The compressor will not be allowed to restart for a minimum of 3 minutes should the FOS close.

Smoke Detector Sensor (Optional)

This sensor is only applicable on units equipped with a RTOM. It provides high limit "shutdown" of the unit and requires a manual reset. The sensor is used to detect smoke due to fire in the air conditioning or ventilation ducts.

Important: The supply and return air smoke detectors are designed to shut off the unit if smoke is sensed in the supply air stream or return air stream. This function is performed by sampling the airflow entering the unit at the return air opening. Follow the instructions provided below to assure that the airflow through the unit is sufficient for adequate sampling. Failure to follow these instructions will prevent the smoke detectors from performing it's design function.

Important: Airflow through the unit is affected by the amount of dirt and debris accumulated on the indoor coil and filters. To insure that airflow through the unit is adequate for proper sampling by the return air smoke detector, complete adherence to the maintenance procedures, including recommended intervals between filter changes, and coil cleaning is required.

Important: Periodic checks and maintenance procedures must be performed on the smoke detector to insure that it will function properly. For detailed instructions concerning these checks and procedures, refer to the appropriate section(s) of the smoke detector Installation and Maintenance Instructions provided with the literature package for this unit.

In order for the supply air smoke detector or return air smoke detector to properly sense smoke in the supply air stream or return air stream, the air velocity entering the smoke detector unit must be between 500 and 4000 feet per minute. Equipment covered in this manual will develop an airflow velocity that falls within these limits over the entire airflow range specified in the evaporator fan performance tables.

There are certain models, however, if operated at low airflow, will not develop an airflow velocity that falls within the required 500 to 4000 feet per minute range. For these models, the design airflow shall be greater than or equal to the minimum CFM specified in the table provided below. Failure to follow these instructions will prevent the smoke detector from performing it's design function.

Unit Model Number	Minimum Allowable Airflow with Return Air Smoke Detector
YCD181	5300 CFM

General Information

Unit Inspection

As soon as the unit arrives at the job site:

- [] Verify that the nameplate data matches the data on the sales order and bill of lading (including electrical data).
- [] Verify that the power supply complies with the unit nameplate specifications.
- [] Visually inspect the exterior of the unit, including the roof, for signs of shipping damage.
- [] Visually inspect the internal components for shipping damage as soon as possible after delivery and before it is stored. Do not walk on the sheet metal base pans.
- [] If concealed damage is discovered, notify the carrier's terminal of damage immediately by phone and by mail. Concealed damage must be reported within 15 days.

Request an immediate joint inspection of the damage by the carrier and the consignee. Do not remove damaged material from the receiving location. Take photos of the damage, if possible. The owner must provide reasonable evidence that the damage did not occur after delivery.
- [] Notify the appropriate sales representative before installing or repairing a damaged unit.



WARNING

Fiberglass Wool

Product contains fiberglass wool. Disturbing the insulation in this product during installation, maintenance or repair will expose you to airborne particles of glass wool fibers and ceramic fibers known to the state of California to cause cancer through inhalation. Glass wool fibers may also cause respiratory, skin or eye irritation.

Precautionary Measures

- **Avoid breathing fiberglass dust.**
- **Use a NIOSH approved dust/mist respirator.**
- **Avoid contact with the skin or eyes. Wear long-sleeved, loose-fitting clothing, gloves, and eye protection.**
- **Wash clothes separately from other clothing: rinse washer thoroughly.**
- **Operations such as sawing, blowing, tear-out, and spraying may generate fiber concentrations requiring additional respiratory protection. Use the appropriate NIOSH approved respiration in these situations.**

First Aid Measures

Eye Contact - Flush eyes with water to remove dust. If symptoms persist, seek medical attention.

Skin Contact - Wash affected areas gently with soap and warm water after handling.

Storage

Take precautions to prevent condensate from forming inside the unit's electrical compartments and motors if:

- a. the unit is stored before it is installed; or,
- b. the unit is set on the roof curb, and temporary heat is provided in the building. Isolate all side panel service entrances and base pan openings (e.g., conduit holes, S/A and R/A openings, and flue openings) from the ambient air until the unit is ready for start-up.

Note: Do not use the unit's heater for temporary heat without first completing the start-up procedure detailed under "Starting the Unit".

The manufacturer will not assume any responsibility for equipment damage resulting from condensate accumulation on the unit's electrical and/or mechanical components.

Unit Clearances

Figure 1 illustrates the minimum operating and service clearances for either a single or multiple unit installation. These clearances are the minimum distances necessary to assure adequate serviceability, cataloged unit capacity, and peak operating efficiency.

Providing less than the recommended clearances may result in condenser coil starvation, "short-circuiting" of exhaust and economizer airflows, or recirculation of hot condenser air.

Unit Dimensions

Figure 1
Typical Installation Clearances for Single & Multiple Unit Applications

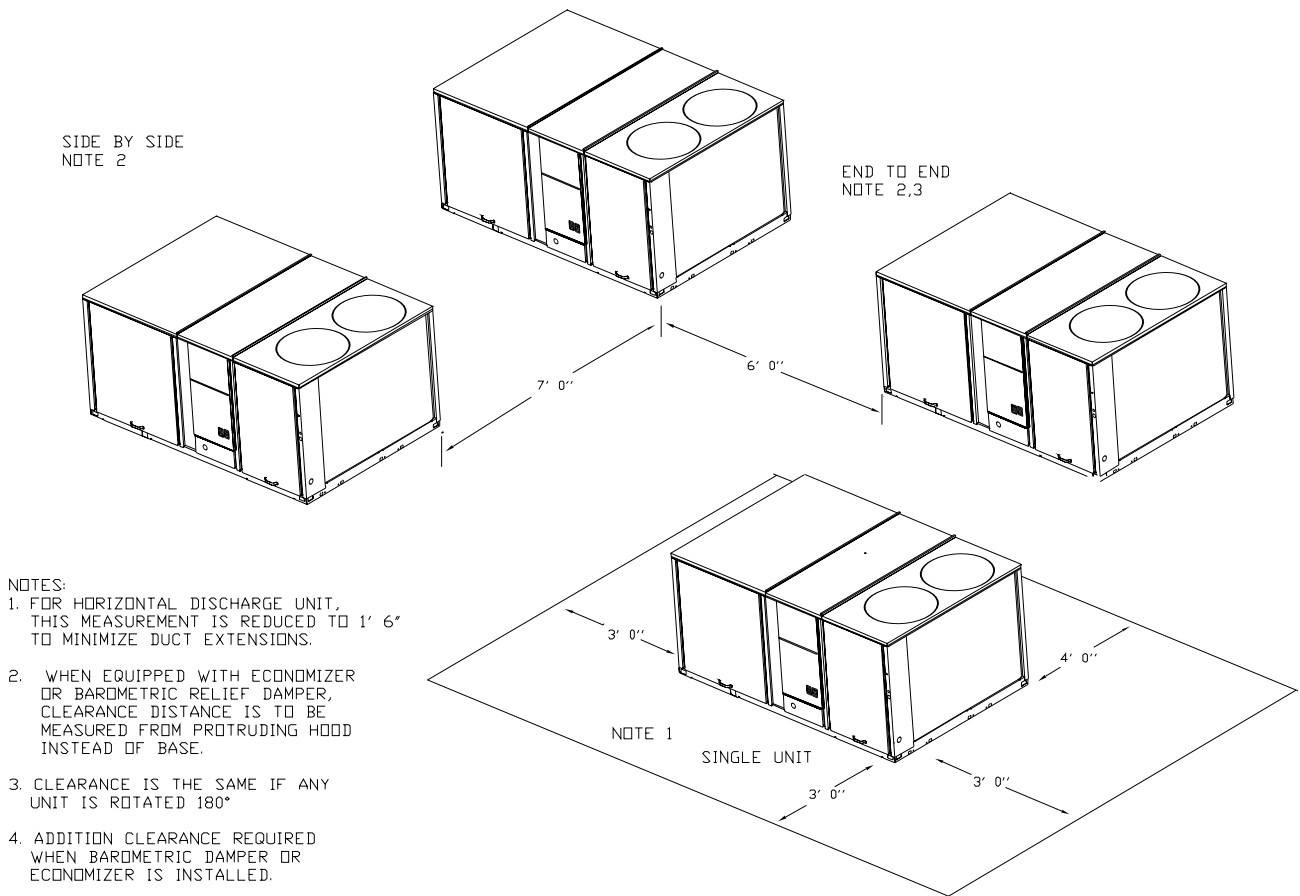

Unit / Curb Dimensions

Figure 2
Unit Dimensional Data
12 1/2 Ton, 15 Ton, 17 1/2 Ton Standard Efficiency
12 1/2 Ton High Efficiency

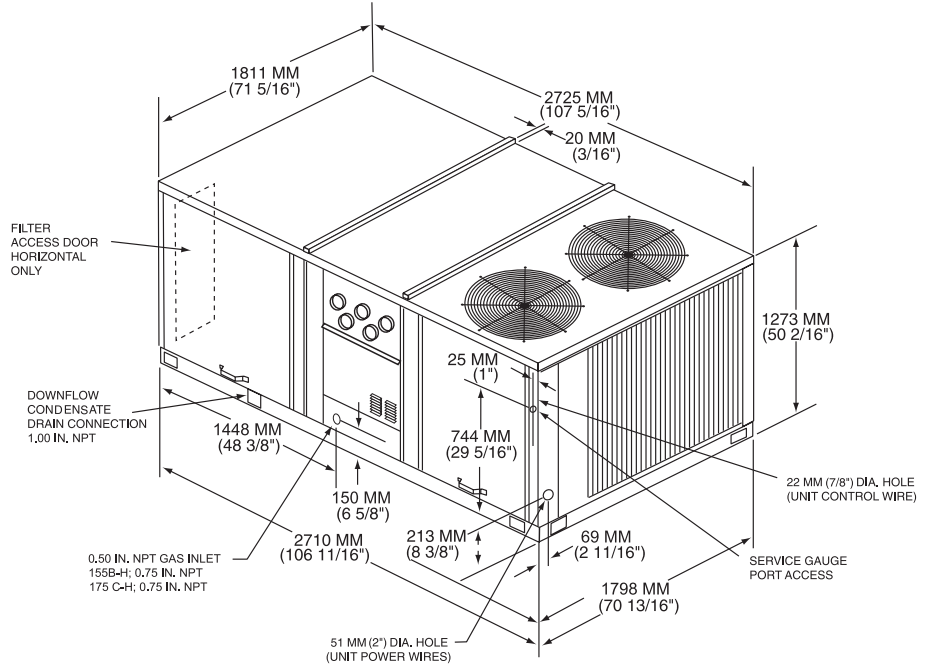

Roof Curb Dimensional Data
12 1/2 Ton, 15 Ton, 17 1/2 Ton Standard Efficiency
12 1/2 Ton High Efficiency

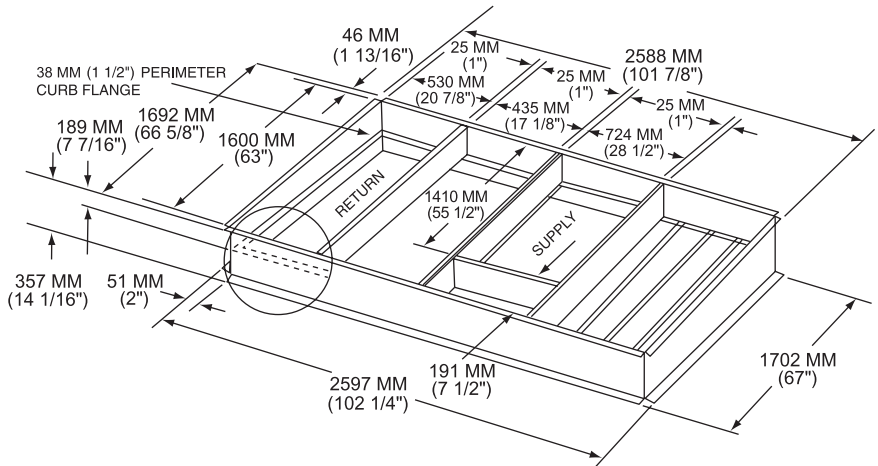

Unit / Curb Dimensions

Figure 3
Unit Dimensional Data
20 Ton, 25 Ton Standard Efficiency
15 - 25 Tons High Efficiency

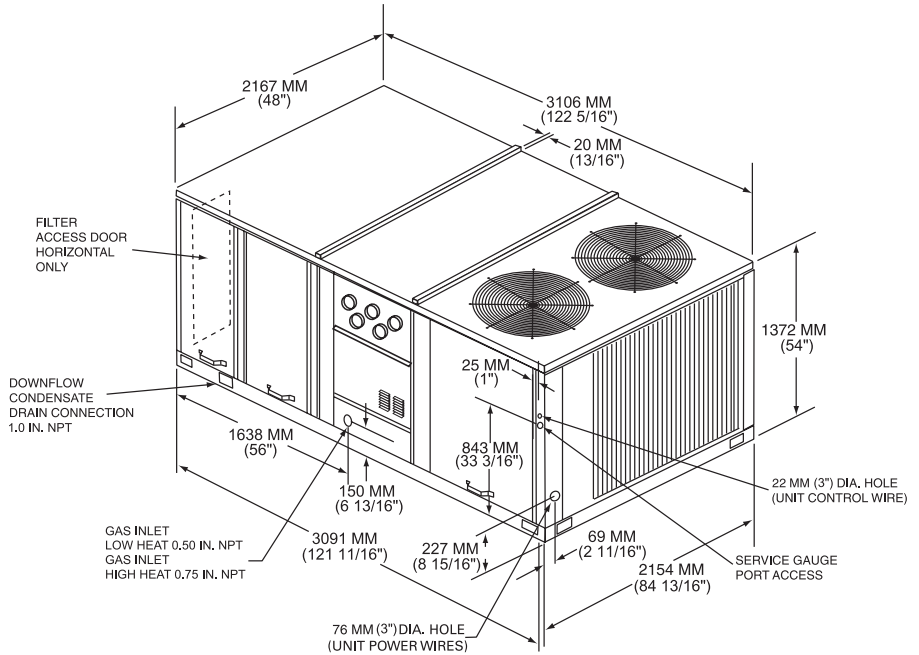

Roofcurb Dimensional Data
20 Ton, 25 Ton Standard Efficiency
15 - 25 Tons High Efficiency

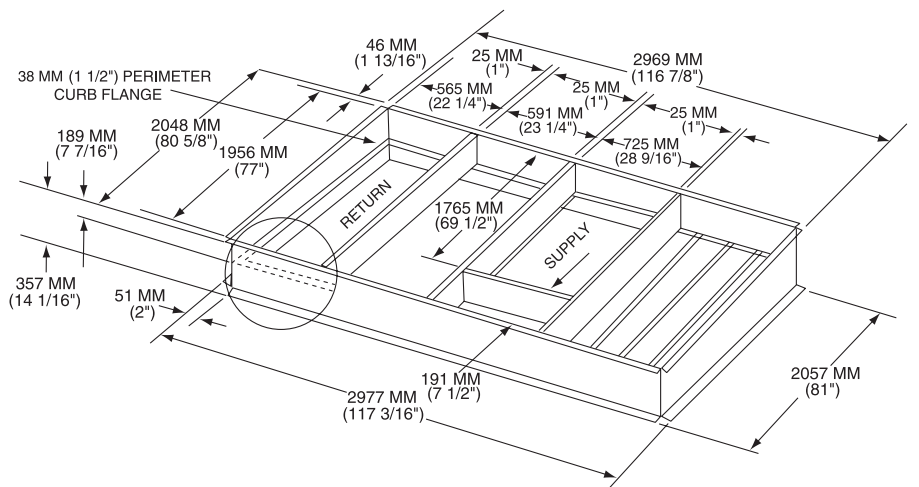

Horizontal Duct Dimensions

Figure 4
Horizontal Duct Dimensional Data
12 1/2 Ton, 15 Ton, 17 1/2 Ton Standard Efficiency
12 1/2 Ton High Efficiency

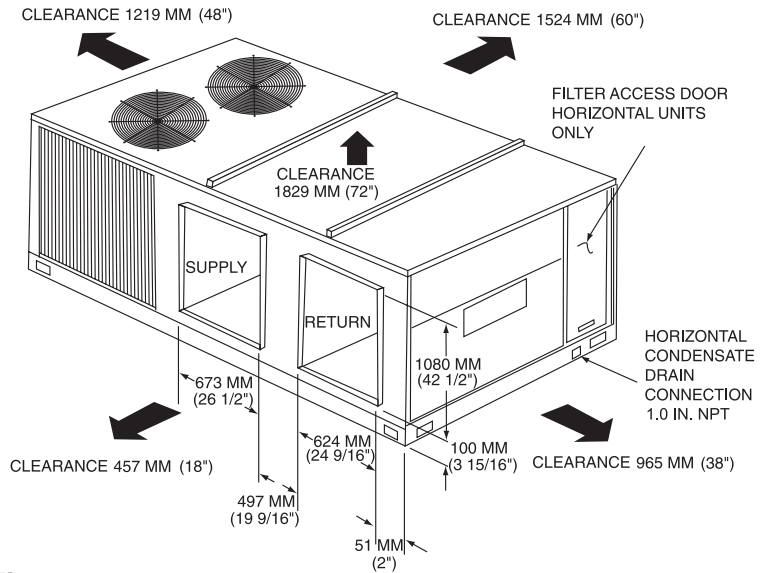
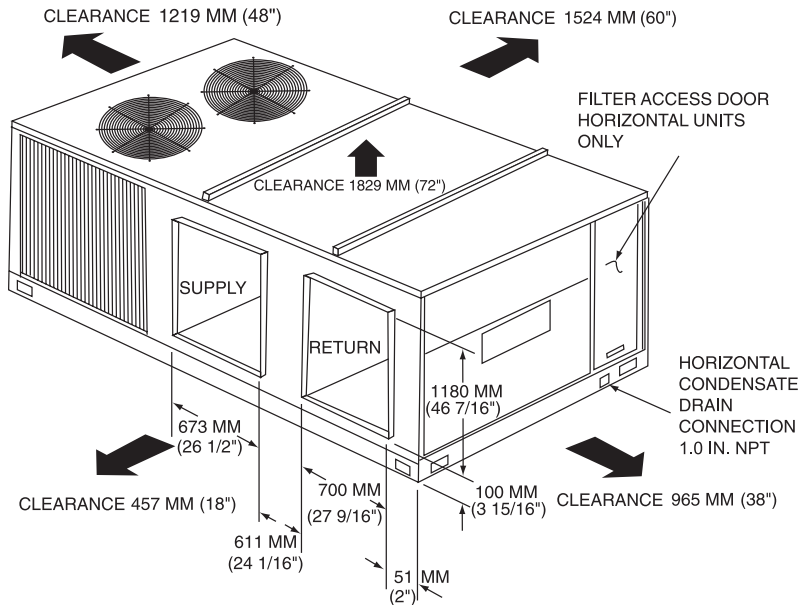

Figure 5
Horizontal Duct Dimensional Data
20 Ton, 25 Ton Standard Efficiency
15 - 25 Tons High Efficiency



Unit Weight / Rigging

Table 1
Typical Unit Weights & Point Loading Data

Unit Models	Net Weight (lbs)	Corner Wts. (lbs)			
		A	B	C	D
YC*150D	1458	495	373	254	336
YC*151C	1547	523	383	271	370
YC*155B	1539	536	388	266	357
YC*180B	1665	600	395	266	404
YC*181C	2005	686	504	345	470
YC*175C	1620	553	414	280	373
YC*210C	1821	618	463	317	424
YC*211C	2088	701	538	369	480
YC*200B	2028	714	534	333	448
YC*240B	2088	738	526	343	481
YC*241C	2186	751	568	373	494
YC*250B	2082	721	552	351	458
YC*300B	2086	721	553	351	459
YC*301C	2191	755	569	373	495

* Downflow or Horizontal

Note: Corner weights are given for information only. Unit is to be supported continuously by a curb or equivalent frame support.

Figure 6
Rigging and Center-of-Gravity Data

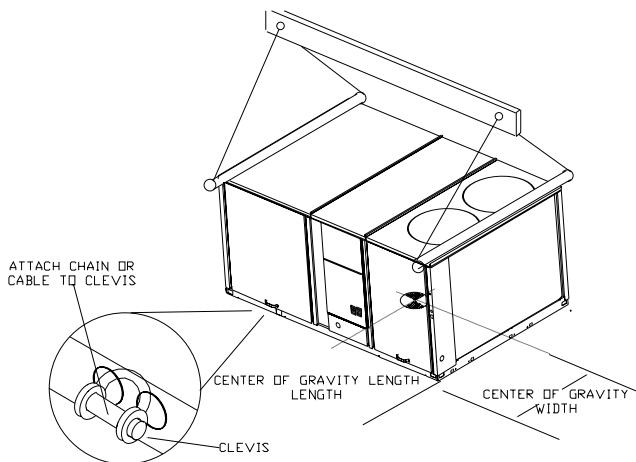

WARNING **Heavy Objects!**

Do not use cables (chains or slings) except as shown. Each of the cables (chains or slings) used to lift the unit must be capable of supporting the entire weight of the unit. Lifting cables (chains or slings) may not be of the same length. Adjust as necessary for even unit lift. Other lifting arrangements may cause equipment or property-only damage. Failure to properly lift unit may result in death or serious injury. See details below.

Unit Models	Net Weight (kg)	Corner Wts. (kg)			
		A	B	C	D
YC*150D	661	225	169	115	152
YC*151C	702	237	174	123	168
YC*155B	698	243	176	121	162
YC*180B	755	272	179	121	183
YC*181C	909	311	229	156	213
YC*175C	735	251	188	127	169
YC*210C	826	280	210	144	192
YC*211C	947	318	244	167	218
YC*200B	920	324	242	151	203
YC*240B	947	335	239	156	218
YC*241C	992	341	258	169	224
YC*250B	944	327	250	159	208
YC*300B	946	327	251	159	208
YC*301C	994	342	258	169	225

* Downflow or Horizontal

WARNING **Improper Unit Lift!**

Test lift unit approximately 24 inches to verify proper center of gravity lift point. To avoid dropping of unit, reposition lifting point if unit is not level. Failure to properly lift unit could result in death or serious injury or possible equipment or property-only damage.

Rigging

Refer to Figure 6 and Table 1 for typical unit operating weights rifting before proceeding.

1. Remove the shipping crate from around the unit. Do not remove the crating from the top of the unit.
2. Rig the unit as shown in Figure 6. Attach adequate strength lifting slings to all four lifting brackets in the unit base rail. Do not use cables, chains, or slings except as shown.
3. Install a lifting bar, as shown in Figure 6, to protect the unit and to facilitate a uniform lift. The minimum distance between the lifting hook and the top of the unit should be 7 feet.
4. Test-lift the unit to ensure it is properly rigged and balanced, make any necessary rigging adjustments.
5. Lift the unit and position it into place.
6. Downflow units; align the base rail of the unit with the curb rail while lowering the unit onto the curb. Make sure that the gasket on the curb is not damaged while positioning the unit.

Installation

Foundation

Horizontal Units

If the unit is installed at ground level, elevate it above the snow line. Provide concrete footings at each support location with a “full perimeter” support structure or a slab foundation for support. Refer to Table 1 for the unit’s operating and point loading weights when constructing a footing foundation.

If anchoring is required, anchor the unit to the slab using hold down bolts or isolators. Isolators should be installed to minimize the transmission of vibrations into the building.

For rooftop applications, ensure the roof is strong enough to support the combined unit and support structural weight. Refer to Table 1 for the unit operating weights. If anchoring is required, anchor the unit to the roof with hold-down bolts or isolators.

Check with a roofing contractor for proper waterproofing procedures.

Ductwork

Elbows with turning vanes or splitters are recommended to minimize air noise due to turbulence and to reduce static pressure.

When attaching the ductwork to the unit, provide a water-tight flexible connector at the unit to prevent operating sounds from transmitting through the ductwork.

All outdoor ductwork between the unit and the structure should be weather proofed after installation is completed.

Note: For sound consideration, cut only the holes in the roof deck for the ductwork penetrations. Do not cut out the entire roof deck within the curb perimeter.

If a Curb Accessory Kit is not used:

- a. The ductwork can be attached directly to the factory-provided flanges around the unit’s supply and return air openings. Be sure to use flexible duct connections at the unit.
- b. For “built-up” curbs supplied by others, gaskets must be installed around the curb perimeter flange and the supply and return air opening flanges.

Installation

General Unit Requirements

The checklist listed below is a summary of the steps required to successfully install a commercial unit. This checklist is intended to acquaint the installing personnel with what is required in the installation process. It does not replace the detailed instructions called out in the applicable sections of this manual.

- [] Check the unit for shipping damage and material shortage; file a freight claim and notify appropriate sales representative.
 - [] Verify correct model, options and voltage from nameplate.
 - [] Verify that the installation location of the unit will provide the required clearance for proper operation.
 - [] Assemble and install the roof curb (if applicable). Refer to the latest edition of the curb installers guide that ships with each curb kit.
 - [] Fabricate and install ductwork; secure ductwork to curb.
 - [] Rigging the unit.
 - [] Set the unit onto the curb; check for levelness.
 - [] Ensure unit-to-curb seal is tight and without buckles or cracks.
 - [] Install and connect a condensate drain line to the evaporator drain connection.
- ### Factory Installed Economizer
- [] Ensure the economizer has been pulled out into the operating position. Refer to the economizer installers guide for proper position and setup.
 - [] Install all access panels.

Main Electrical Power Requirements

- [] Verify that the power supply complies with the unit nameplate specifications.
- [] Inspect all control panel components; tighten any loose connections.
- [] Connect properly sized and protected power supply wiring to a field-supplied/installed disconnect switch and to the main power terminal block (HTB1) in the unit control panel.
- [] Install proper grounding wires to an earth ground.

Note: All field-installed wiring must comply with NEC and applicable local codes.

Electric Heat Requirements

- [] Verify that the power supply complies with the electric heater specifications on the unit and heater nameplate.
- [] Inspect the heater junction box and control panel; tighten any loose connections.
- [] Check electric heat circuits for continuity.

Low Voltage Wiring (AC & DC) Requirements

- [] Install the zone thermostat, with or without switching subbase.
- [] Connect properly sized control wiring to the proper termination points between the zone thermostat and the unit control panel.

Condensate Drain Configuration

An evaporator condensate drain connection is provided on each unit. Refer to Figures 2, 3, 4 or 5 for the appropriate drain location.

A condensate trap must be installed at the unit due to the drain connection being on the “negative pressure” side of the fan. Install the P-Trap using the guidelines in Figure 7.

A condensate drain line must be connected to the P-Trap. Pitch the drain lines at least 1/2 inch for every 10 feet of horizontal run to assure proper condensate flow. Do not allow the horizontal run to sag causing a possible double-trap condition which could result in condensate backup due to “air lock”.

**Figure 7
Condensate Trap Installation**

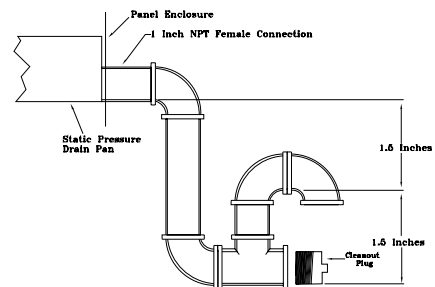

Filter Installation

Each unit ships with 2 inch filters installed. The quantity of filters is determined by unit size. Access to the filters is obtained by removing the indoor fan access panel.

Refer to the unit Service Facts (shipped with each unit) for filter requirements.

Note: Do not operate the unit without filters.

Installation

Field Installed Power Wiring

An overall dimensional layout for the standard field installed wiring entrance into the unit is illustrated in Figures 2, and 3. To insure that the unit's supply power wiring is properly sized and installed, follow the guidelines outlined below.

Note: All field installed wiring must conform to NEC guidelines as well as State and Local codes.

Verify that the power supply available is compatible with the unit's nameplate ratings. The available supply power must be within 10% of the rated voltage stamped on the nameplate. Use only copper conductors to connect the power supply to the unit.

CAUTION Use Copper Conductors Only!

Unit terminals are not designed to accept other types of conductors. Failure to use copper conductors may result in equipment damage.

Failure to do so may cause damage to the equipment.

Note: If the unit is *not* equipped with an optional factory installed nonfused disconnect switch or circuit breaker, a field supplied disconnect switch must be installed at or near the unit in accordance with the National Electrical Code (NEC latest edition).

Main Unit Power Standard Wiring

The electrical service must be protected from over current and short circuit conditions in accordance with NEC requirements. Protection devices must be sized according to the electrical data on the nameplate.

1. If the unit is *not* equipped with an optional factory installed nonfused disconnect switch or circuit breaker, a field supplied disconnect switch must be installed at or near the unit in accordance with the National Electrical Code (NEC latest edition).
2. Location of the applicable electrical service entrance is illustrated in Figures 2 or 3. Complete the unit's power wiring connections onto either; the main terminal block HTB1 inside the unit control panel, the factory mounted nonfused disconnect switch (UCD) or circuit breaker (UCB), or the electric heat terminal block. Refer to the customer connection diagram that shipped with the unit for specific termination points.
3. Provide proper grounding for the unit in accordance with local and national codes.

Installation

Main Unit Power Optional TBUE Wiring (Through the Base Electrical Option)

1. Location of the applicable electrical service is illustrated below. Refer to the customer connection diagram that is shipped with the unit for specific termination points. The termination points, depending on the customer option selected would be a factory mounted nonfused disconnect switch (UDC) or circuit breaker (UCB).
2. Provide proper grounding for the unit in accordance with local and national codes.

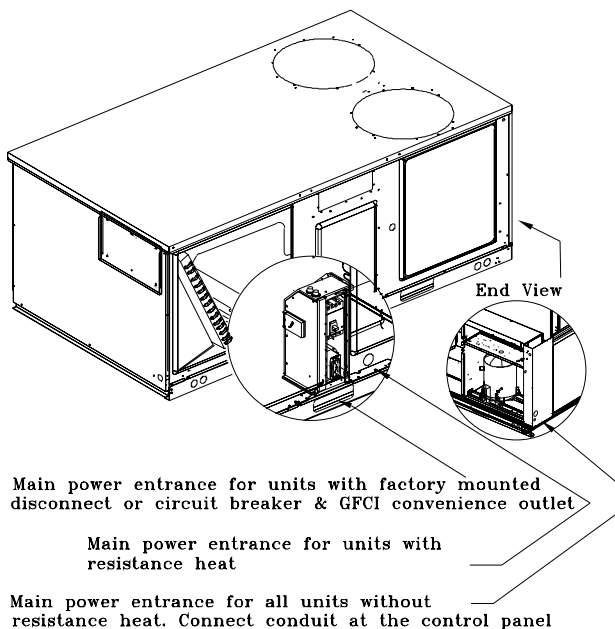

Field Installed Control Wiring

An overall layout of the various control options available with the required number of conductors for each control device is illustrated in Figure 8.

Note: All field wiring must conform to NEC guidelines as well as state and local codes.

Control Power Transformer

The 24 volt control power transformers are to be used only with the accessories called out in this manual. Transformers rated greater than 50 VA are equipped with internal circuit breakers. If a circuit breaker trips, turn "Off" all power to the unit before attempting to reset it.

WARNING Hazardous Voltage!

Disconnect all electric power, including remote disconnects before servicing. Follow proper lockout/tagout procedures to ensure the power can not be inadvertently energized. Failure to disconnect power before servicing could result in death or serious injury.

Failure to disconnect power before servicing can cause severe personal injury or death.

The transformer is located in the control panel. The circuit breaker is located on the left side of the transformer and can be reset by pressing in on the black reset button.

Controls using 24 VAC

Before installing any connecting wiring, refer to Figure 2 or 3 for the electrical access locations provided on the unit and Table 2 for AC conductor sizing guidelines, and;

- a. Use copper conductors unless otherwise specified.
- b. Ensure that the AC control wiring between the controls and the unit's termination point does not exceed three (3) ohms/conductor for the length of the run.

Note: Resistance in excess of 3 ohms per conductor may cause component failure due to insufficient AC voltage supply.

- c. Be sure to check all loads and conductors for grounds, shorts, and mis-wiring.
- d. Do not run the AC low voltage wiring in the same conduit with the high voltage power wiring.
- e. Route low voltage wiring per illustrations on page 19.

**Table 2 - Electromechanical Thermostat
24V AC Conductors with Reliabel**

Distance from Unit to Control	Recommended Wire Size
000 - 460 feet	18 gauge
000 - 140 m	.75 mm ²
461 - 732 feet	16 gauge

Installation

Controls using DC Analog Input/Outputs (Standard Low Voltage Multiconductor Wire)

Before installing any connecting wiring between the unit and components utilizing a DC analog input/output signal, refer to Figure 2 or 3 for the electrical access locations provided on the unit.

- Table 3 lists the conductor sizing guidelines that must be followed when interconnecting the DC binary output devices and the system components utilizing a DC analog input/output signal to the unit.

Note: Resistance in excess of 2.5 ohms per conductor can cause deviations in the accuracy of the controls.

- Ensure that the wiring between controls and the unit's termination point does not exceed two and a half (2.5) ohms/conductor for the length of the run.
- Do not run the electrical wires transporting DC signals in or around conduit housing high voltage wires.

DC Conductors

Table 3

Zone Sensor Module wiring	
Distance from Unit to Control	Recommended Wire Size
0 - 150 feet	22 gauge
0 - 45.7 m	.33 mm ²
151 - 240 feet	20 gauge
46 - 73.1 m	.50 mm ²
241 - 385 feet	18 gauge

ReliaTel Options Module

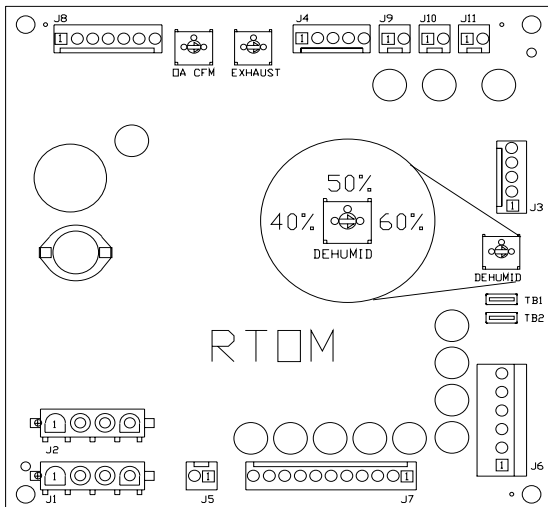

ReliaTel Conventional Thermostat Field Wiring Diagrams

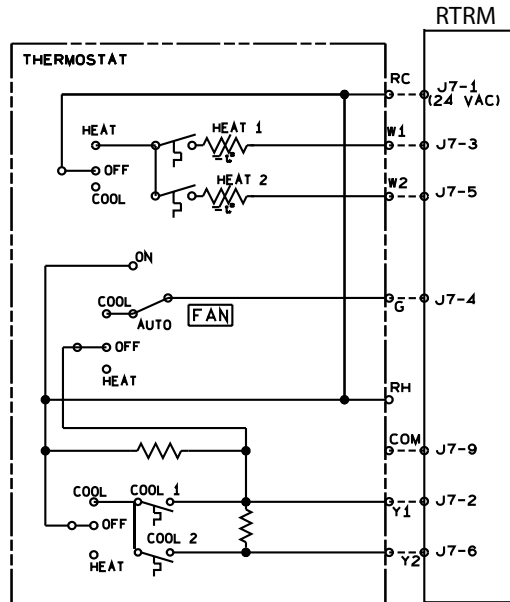

ReliaTel Relative Humidity Sensor (Dehumidification Option)

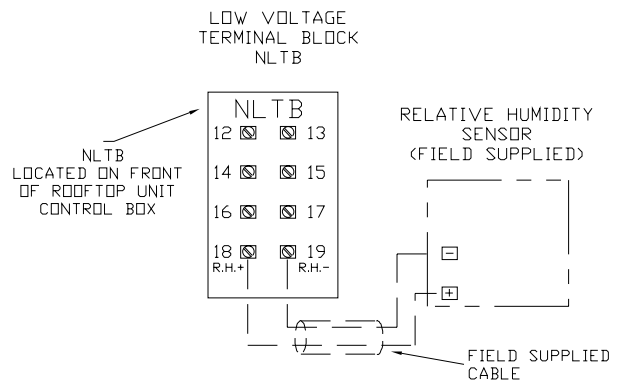

ReliaTel Humidistat (Dehumidification Option)

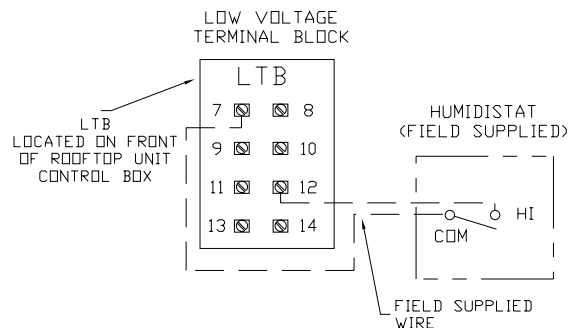

Installation

Smoke Detector Customer Low Voltage Wiring-

When interlocking System Sensor smoke detectors together, all of the detectors must be powered from the same power supply. If multiple smoke detectors are required, all detectors must be disconnected from the HVAC unit power supply and connected together from another single source supply.

Note: Do not interconnect smoke detectors together that have separate power supplies. Do not exceed ten smoke detectors on one power supply.

Note: Multiple System Sensor smoke detectors are connected together using terminals 1 and 12 on each detector.

If you have supply and return smoke detectors in all HVAC units, you can connect a maximum of 5 HVAC units (10 detectors) up to one power supply. See the following field wiring example below.

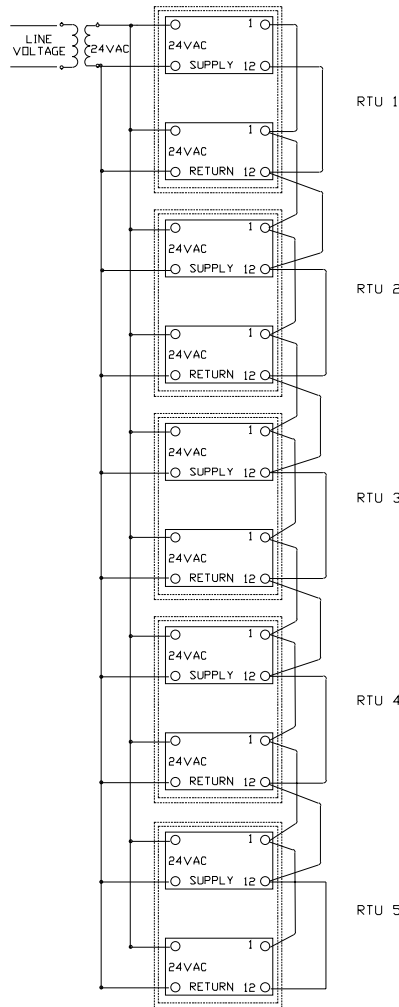

If you have more than 5 HVAC units, you can connect all the supply detectors together on one power supply (up to 10 HVAC units), and all the return detectors together (up to 10 HVAC units) on another power supply. See the following field wiring example below.

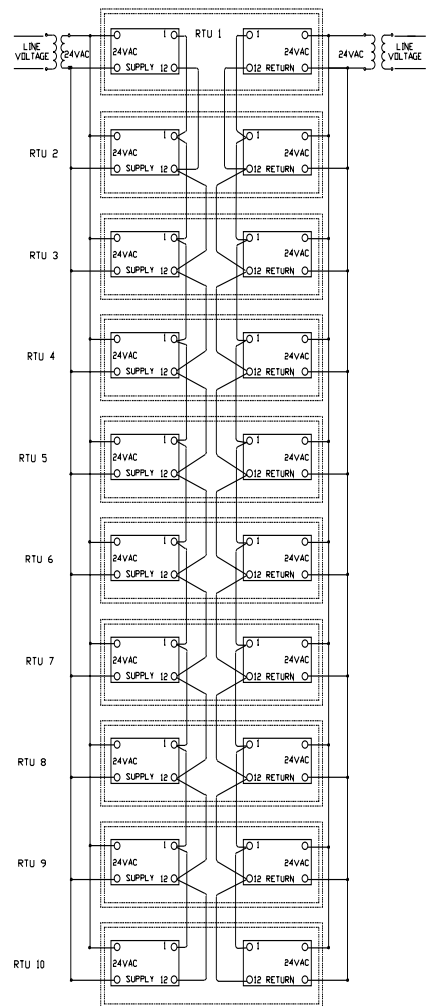

Installation

Figure 8
Typical Field Wiring Diagrams for Optional Controls (ReliaTel™ only)

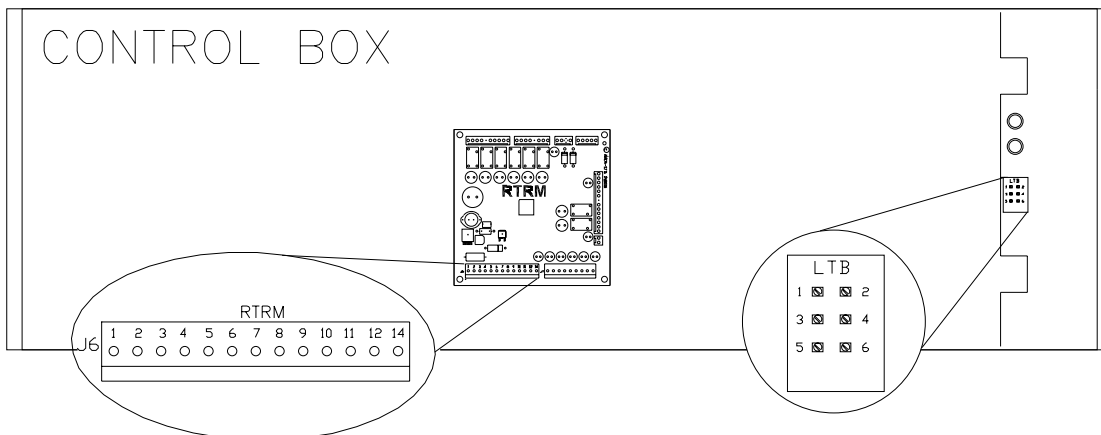
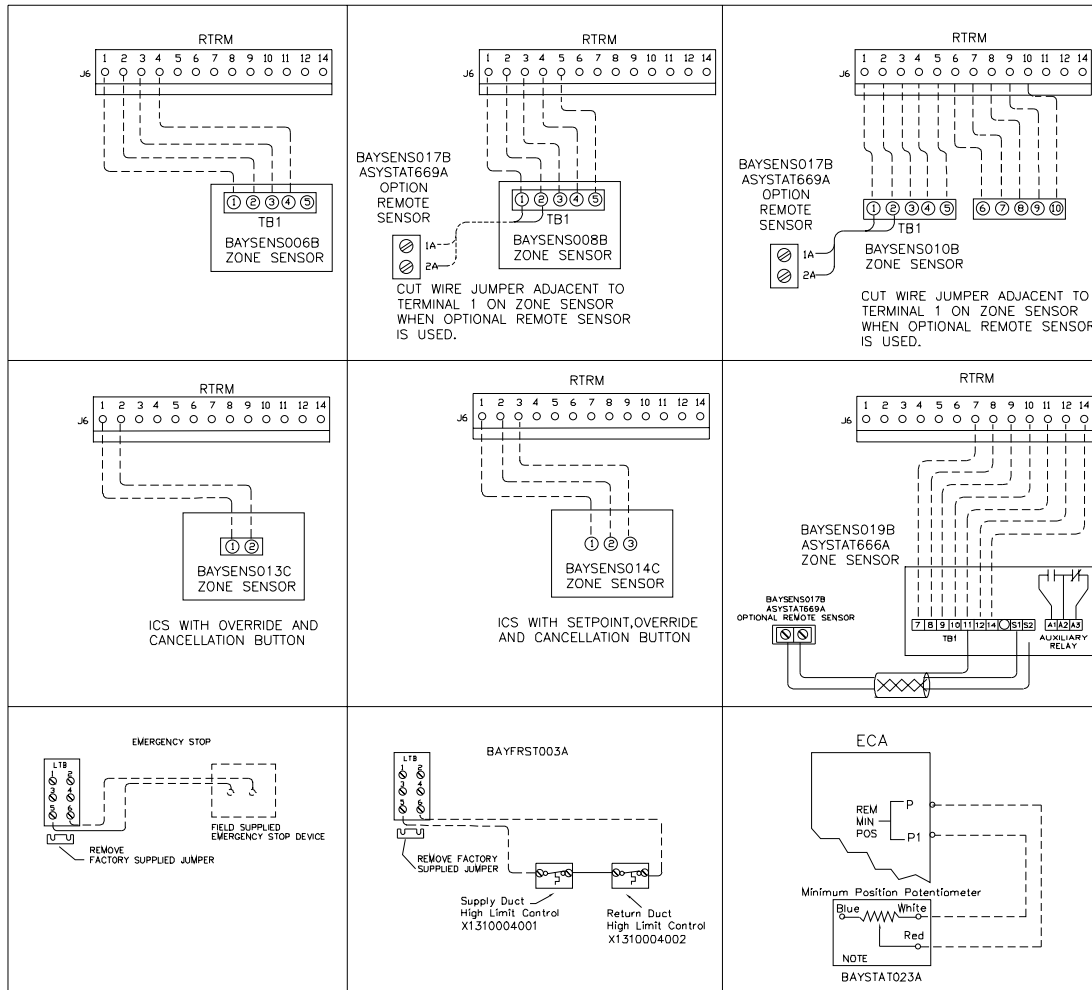

Installation

Space Temperature Averaging

Space temperature averaging is accomplished by wiring a number of remote sensors in a series/parallel circuit.

Using the BAYSENS016* or BAYSENS017*, at least four sensors are required to accomplish space temperature averaging. Example #1 illustrates two series circuits with two sensors in each circuit wired in parallel. The square of any number of remote sensors is required. Example #2 illustrates three sensors squared in a series/parallel circuit. Using BAYSENS032*, two sensors are required to accomplish space temperature averaging. Example #3 illustrates the circuit required for this sensor. Table 4 lists the temperature versus resistance coefficient for all sensing

EXAMPLE #1

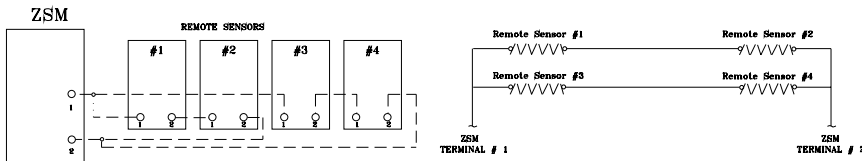

EXAMPLE #2

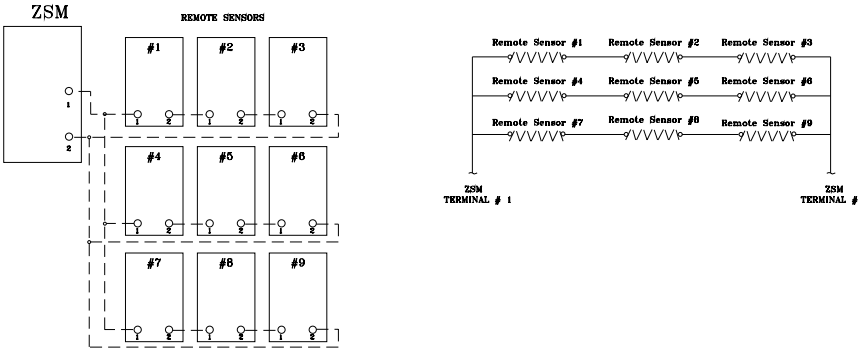

EXAMPLE #3



Table 4
Temperature vs. Resistance
Temperature

Degrees F°	Degrees C°	Nominal Resistance
-20°	-28.9°	170.1 K - Ohms
-15°	-26.1°	143.5 K - Ohms
-10°	-23.3°	121.4 K - Ohms
-5°	-20.6°	103.0 K - Ohms
0°	-17.8°	87.56 K - Ohms
5°	-15.0°	74.65 K - Ohms
10°	-12.2°	63.80 K - Ohms
15°	-9.4°	54.66 K - Ohms
20°	-6.7°	46.94 K - Ohms
25°	-3.8°	40.40 K - Ohms
30°	-1.1°	34.85 K - Ohms
35°	1.7°	30.18 K - Ohms
40°	4.4°	26.22 K - Ohms
45°	7.2°	22.85 K - Ohms
50°	10.0°	19.96 K - Ohms
55°	12.8°	17.47 K - Ohms
60°	15.6°	15.33 K - Ohms
65°	18.3°	13.49 K - Ohms
70°	21.1°	11.89 K - Ohms
75°	23.9°	10.50 K - Ohms
80°	26.7°	9.297 K - Ohms
85°	29.4°	8.247 K - Ohms
90°	32.2°	7.330 K - Ohms
95°	35.0°	6.528 K - Ohms
100°	37.8°	5.824 K - Ohms

Installation

Gas Heater Operating Data

Heating Input Rate – BTUH ³	135,000	205,000
Minimum Supply Gas Pressure	3.5" w.c./ 8.0" w.c.	
Manifold Gas Pressure (See Note 1)	-0.2" w.c.	
Combustion Blower Suction Pressure (1st Stage)	-2.1 to -3.1" w.c.	-0.8 to -1.2" w.c.
(With Gas Valve Closed)	N/A	-2.1 to -3.1" w.c.
(2nd Stage)		
Minimum Flame Sensing Current (See Note 2)	5.0 Microamps D.C.	
Normal Sensing Current Range	8.0 to 16.0 Microamps D.C.	
Flue Gas Temperature Rise Above Ambient	400 to 500 F	350 to 475 F
Flue Gas Content - %CO ₂	Natural	8.0 to 9.0
	LP	9.5 to 10.5
Minimum Supply Air Temperature Across Heat Exchanger	40 F	

Notes:

1. This Unit has a negative pressure gas valve. Never adjust to a positive pressure.
2. A voltage reading across pens (V+) & (V-) is equatable to the flame sensing current. One volt equals one micro amp.
3. For 50 Hertz applications, multiply rated BTUH by 83 percent.

Length of Pipe (Ft.)	Iron Pipe Size (IPS) Inches				
	1/2" Pipe	3/4" Pipe	1" Pipe	1 1/4" Pipe	1 1/2" Pipe
15	76	176	345	750	1220
30	52	120	241	535	850
45	43	99	199	435	700
60	38	86	173	380	610
75		77	155	345	545

Capacity of Pipe of Different Diameters and Lengths in Cu. Ft. Per Hr. with Pressure Drop of 0.3" and Specific Gravity of 0.60

Specific Gravity Multipliers

Specific Gravity	Multiplier
0.50	1.10
0.55	1.04
0.60	1.00
0.65	0.96

Schematic Diagram for Field Gas Piping to Unit

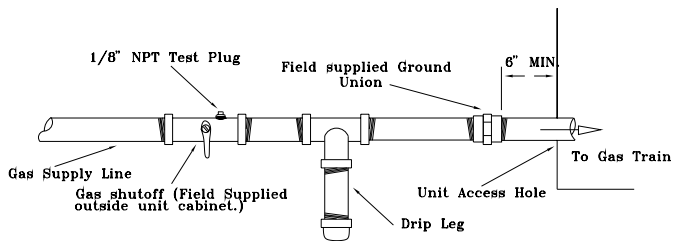

Typical Unit Gas Train Configuration

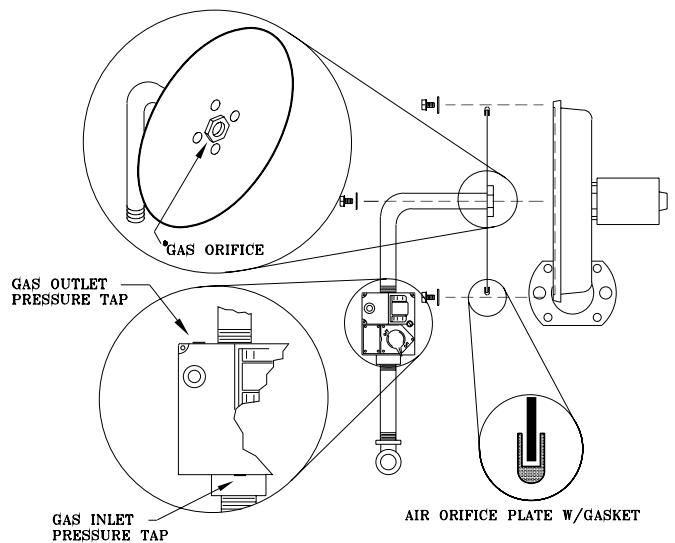

Installation

Use the checklist provided below in conjunction with the “General Unit Requirements” checklist to ensure that the unit is properly installed and ready for operation.

WARNING

Hazardous Voltage!

Disconnect all electric power, including remote disconnects before servicing. Follow proper lockout/tagout procedures to ensure the power can not be inadvertently energized. Failure to disconnect power before servicing could result in death or serious injury.

Failure to disconnect power before servicing can cause severe personal injury or death.

- [] Check all electrical connections for tightness and “point of termination” accuracy.
- [] Verify that the condenser airflow will be unobstructed.
- [] Verify that the condenser fan and indoor blower turn freely without rubbing and are properly tightened on the shafts.
- [] Check the supply fan belts for proper tension and the fan bearings for sufficient lubrication. If the belts require adjustment, or if the bearings need lubricating, refer to the maintenance section of this manual for instructions.
- [] Verify that a condensate trap is installed and the piping is properly sized and pitched.
- [] Verify that the correct size and number of filters are in place.
- [] Inspect the interior of the unit for tools and debris and install all panels in preparation for starting the unit.

Voltage Imbalance

Three phase electrical power to the unit must meet stringent requirements for the unit to operate properly. Measure each leg (phase-to-phase) of the power supply. Each reading must fall within the utilization range stamped on the unit nameplate. If any of the readings do not fall within the proper tolerances, notify the power company to correct this situation before operating the unit.

Excessive three phase voltage imbalance between phases will cause motors to overheat and eventually fail. The maximum allowable voltage imbalance is 2%. Measure and record the voltage between phases 1, 2, and 3 and calculate the amount of imbalance as follows:

% Voltage Imbalance =

$$100 \times \frac{AV - VD}{AV} \text{ where;}$$

AV (Average Voltage) =

$$\frac{\text{Volt 1} + \text{Volt 2} + \text{Volt 3}}{3}$$

V1, V2, V3 = Line Voltage Readings
VD = Line Voltage reading that deviates the farthest from the average voltage.

Example: If the voltage readings of the supply power measured 221, 230, and 227, the average volts would be:

$$\frac{221 + 230 + 227}{3} = 226 \text{ Avg.}$$

VD (reading farthest from average) = 221

The percentage of Imbalance equals:

$$100 \times \frac{226 - 221}{226} = 2.2\%$$

The 2.2% imbalance in this example exceeds the maximum allowable imbalance of 2.0%. This much imbalance between phases can equal as much as a 20% current imbalance with a resulting increase in motor winding temperatures that will decrease motor life. If the voltage imbalance is over 2%, notify the proper agencies to correct the voltage problem before operating this equipment.

Electrical Phasing (Three Phase Motors)

The compressor motor(s) and the supply fan motor are internally connected for the proper rotation when the incoming power supply is phased as A, B, C.

Proper electrical supply phasing can be quickly determined and corrected before starting the unit by using an instrument such as an Associated Research Model 45 Phase Sequence Indicator and following the steps below:

- [] Turn the field supplied disconnect switch that provides power to the main power terminal block or to the “Line” side of the optional factory mounted disconnect switch to the “Off” position.
- [] Connect the phase sequence indicator leads to the terminal block or to the “Line” side of the optional factory mounted disconnect switch as follows;

Black (phase A)	to	L1
Red (phase B)	to	L2
Yellow (phase C)	to	L3

- [] Close the field supplied main power disconnect switch or circuit protector switch that provides the supply power to the unit.

Installation

WARNING

Live Electrical Components!

During installation, testing, servicing and troubleshooting of this product, it may be necessary to work with live electrical components. Have a qualified licensed electrician or other individual who has been properly trained in handling live electrical components perform these tasks. Failure to follow all electrical safety precautions when exposed to live electrical components could result in death or serious injury.

To prevent injury or death from electrocution, it is the responsibility of the technician to recognize this hazard and use extreme care when performing service procedures with the electrical power energized.

- [] Observe the ABC and CBA phase indicator lights on the face of the sequencer. The ABC indicator light will glow if the phase is ABC. If the CBA indicator light glows, open the disconnect switch or circuit protection switch and reverse any two power wires.
- [] Restore the main electrical power and recheck the phasing. If the phasing is correct, open the disconnect switch or circuit protection switch and remove the phase sequence indicator.

Compressor Crankcase Heaters (Optional)

Each compressor can be equipped with a crankcase heater. The proper operation of the crankcase heater is important to maintain an elevated compressor oil temperature during the “Off” cycle to reduce oil foaming during compressor starts. Oil foaming occurs when refrigerant condenses in the compressor and mixes with the oil. In lower ambient conditions, refrigerant migration to the compressor could increase.

When the compressor starts, the sudden reduction in crankcase pressure causes the liquid refrigerant to boil rapidly causing the oil to foam. This condition could damage compressor bearings due to reduced lubrication and could cause compressor mechanical failures.

Before starting the unit in the “Cooling” mode, set the system switch to the “Off” position and turn the main power disconnect to the “On” position and allow the crankcase heater to operate a minimum of 8 hours.

Before closing the main power disconnect switch, insure that the “System” selection switch is in the “Off” position and the “Fan” selection switch is in the “Auto” position.

Close the main power disconnect switch and the unit mounted disconnect switch, if applicable.

WARNING

Live Electrical Components!

During installation, testing, servicing and troubleshooting of this product, it may be necessary to work with live electrical components. Have a qualified licensed electrician or other individual who has been properly trained in handling live electrical components perform these tasks. Failure to follow all electrical safety precautions when exposed to live electrical components could result in death or serious injury.

To prevent injury or death from electrocution, it is the responsibility of the technician to recognize this hazard and use extreme care when performing service procedures with the electrical power energized.

ReliaTel Controls

Upon power initialization, the RTRM performs self-diagnostic checks to insure that all internal controls are functional. It also checks the configuration parameters against the components connected to the system. The Liteport LED located on the RTRM module is turned “On” within one second of power-up if internal operation is okay.

Use one of the following “Test” procedure to bypass some time delays and to start the unit at the control panel. Each step of unit operation can be activated individually by temporarily shorting across the “Test” terminals for two to three seconds. The Liteport LED located on the RTRM module will blink when the test mode has been initiated. The unit can be left in any “Test” step for up to one hour before it will automatically terminate, or it can be terminated by opening the main power disconnect switch. Once the test mode has been terminated, the Liteport LED will glow continuously and the unit will revert to the “System” control.

Pre - Start

Test Modes

There are three methods in which the "Test" mode can be cycled at LTB-Test 1 and LTB-Test 2.

1. Step Test Mode - This method initiates the different components of the unit, one at a time, by temporarily shorting across the two test terminals for two to three seconds.

For the initial start-up of the unit, this method allows the technician to cycle a component "On" and have up to one hour to complete the check.

2. Resistance Test Mode - This method can be used for start-up providing a decade box for variable resistance outputs is available. This method initiates the different components of the unit, one at a time, when a specific resistance value is placed across the two test terminals. The unit will remain in the specific test mode for approximately one hour even though the resistance is left on the test terminals.

3. Auto Test Mode - This method is not recommended for start-up due to the short timing between individual component steps. This method initiates the different components of the unit, one at a time, when a jumper is installed across the test terminals. The unit will start the first test step and change to the next step every 30 seconds. At the end of the test mode, control of the unit will automatically revert to the applied "System" control method.

For unit test steps, test modes, and step resistance values to cycle the various components, refer to Table 5.

Table 5
Service Test Guide for Component Operation

TEST STEP	MODE	Fan	Econ (Note 2)	Comp 1	Comp 2	Heat 1	Heat 2	Ohms
1	Fan	On	Minimum Position Setpoint 0%	Off	Off	Off	Off	2.2K
	Minimum Ventilation	On	Selectable	Off	Off	Off	Off	
2	Economizer Test Open	On	Open	Off	Off	Off	Off	3.3K
3	Cool Stage 1	On	Minimum Position	(Note 1) On	Off	Off	Off	4.7K
4 (Note 3)	Cool Stage 2	On	Minimum Position	(Note 1) On	(Note 1) On	Off	Off	6.8K
5 (Note 3)	Reheat	On	Minimum	On	On	Off	Off	33K
6 (Note 3)	Heat Stage 1	On	Minimum	Off	Off	On	Off	10K
7 (Note 3)	Heat Stage 2	On	Minimum	Off	Off	On	On	15K

Notes:

- 1 - The condenser fans will operate any time a compressor is "On" providing the outdoor air temperatures are within the operating values.

Pre - Start

Verifying Proper Air Flow (Units with Belt Drive Indoor Fan)

Much of the systems performance and reliability is closely associated with, and dependent upon having the proper airflow supplied both to the space that is being conditioned and across the evaporator coil.

The indoor fan speed is changed by opening or closing the adjustable motor sheave.

Before starting the SERVICE TEST, set the minimum position setpoint for the economizer to 0 percent using the setpoint potentiometer located on the Economizer Control (ECA), if applicable.

ReliaTel Control

Using the Service Test Guide in Table 5, momentarily jump across the Test 1 & Test 2 terminals on LTB1 one time to start the Minimum Ventilation Test.

Once the supply fan has started, check for proper rotation. The direction of rotation is indicated by an arrow on the fan housing.

With the fan operating properly, determine the total system airflow (CFM) by;

1. Measuring the actual RPM,
2. Measure the amperage at the supply fan contactor and compare it with the full load amp (FLA) rating stamped on the motor nameplate.
 - a. Calculate the theoretical BHP

Actual Motor Amps X Motor HP Motor Nameplate Amps

- b. Using the fan performance tables in the unit Service Facts, plot the actual RPM (step 1) and the BHP (step 2a) to obtain the operating CFM.

3. If the required CFM is too low, (external static pressure is high causing motor HP output to be below table value),

- a. Relieve supply and/or return duct static.
- b. Change indoor fan speed and repeat steps 1 and 2.

1. To Increase Fan RPM; Loosen the pulley adjustment set screw and turn sheave clockwise.

2. To Decrease Fan RPM; Loosen the pulley adjustment set screw and turn sheave counterclockwise.

3. If the required CFM is too high, (external static pressure is low causing motor HP output to be above table value), change indoor fan speed and repeat steps 1 and 2.

4. To stop the SERVICE TEST, turn the main power disconnect switch to the "Off" position or proceed to the next component start-up procedure. Remove electro mechanical test mode connections (if applicable).

Return Air Smoke Detector

The return air smoke detector is designed to shut off the unit if smoke is sensed in the return air stream. Sampling the airflow entering the unit at the return air opening performs this function.

In order for the smoke detector to properly sense smoke in the return air stream, the air velocity entering the unit must be between 500 and 4000 feet per minute. Equipment covered in this manual will develop an airflow velocity that falls within these limits over the entire airflow range specified in the evaporator fan performance tables.

There are certain models however, if operated at low airflow, will not develop an airflow velocity that falls within the required 500 to 4000 feet per minute range. For these models, the design airflow shall be greater than or equal to the minimum CFM specified in the table provided below. Failure to follow these instructions will prevent the smoke detector from performing its design function.

Start Up

Economizer Start-Up

ReliaTel Control

Using the Service Test Guide in Table 5, momentarily jump across the Test 1 & Test 2 terminals on LTB1 one time to start the Minimum Ventilation Test.

1. Set the minimum position setpoint for the economizer to the required percentage of minimum ventilation using the setpoint potentiometer located on the Economizer Control (ECA).

The economizer will drive to its minimum position setpoint, exhaust fans (if applicable) may start at random, and the supply fan will start when the SERVICE TEST is initiated.

WARNING Rotating Components!

During installation, testing, servicing and troubleshooting of this product it may be necessary to measure the speed of rotating components. Have a qualified or licensed service individual who has been properly trained in handling exposed rotating components, perform these tasks. Failure to follow all safety precautions when exposed to rotating components could result in death or serious injury.

The Exhaust Fan will start anytime the economizer damper position is equal to or greater than the exhaust fan setpoint.

2. Verify that the dampers stroked to the minimum position.
3. Momentarily jump across the Test 1 & Test 2 terminals on LTB one additional time if continuing from previous component start-up or until the desired start-up component Test is started.
4. Verify that the dampers stroked to the full open position.

5. To stop the SERVICE TEST, turn the main power disconnect switch to the "Off" position or proceed to the next component start-up procedure. Remove electro mechanical test mode connections (if applicable).

Compressor Start-Up

1. Attach a set of service gauges onto the suction and discharge gauge ports for each circuit. Refer to the refrigerant circuit illustration in the Service Facts.

Using the Service Test Guide in Table 5, continue the SERVICE TEST start-up procedure for each compressor circuit.

Momentarily jump across the Test 1 & Test 2 terminals on LTB1 one additional time if continuing from previous component start-up or until the desired start-up component Test is started.

Scroll Compressors

- a. Once each compressor has started, verify that the rotation is correct. If a scroll compressor is rotating backwards, it will not pump and a loud rattling sound can be observed.
- b. If the electrical phasing is correct, before condemning a compressor, interchange any two leads (at the compressor Terminal block) to check the internal phasing. Refer to the following illustration for the compressor terminal/phase identification. If the compressor runs backward for an extended period (15 to 30 minutes), the motor winding can overheat and cause the motor winding thermostat to open.

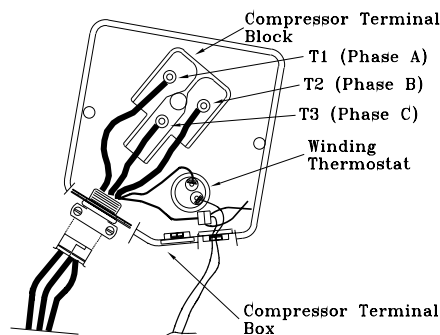

- c. Check the compressor oil levels. The oil level in each compressor sight glass should be 1/2 to 3/4 full when they are "Off".

The scroll compressor uses Trane OIL-42 without substitution. The appropriate oil charge for a 9 and 10 Ton scroll compressor is 8 pints. For a 14 and 15 Ton scroll compressor, use 14 pints.

2. After the compressor and condenser fan have started and operated for approximately 30 minutes, observe the operating pressures. Compare the operating pressures to the operating pressure curve in the Service Facts.
3. Check system superheat. Follow the instruction listed on the superheat charging curve in the Service Facts.

Superheat should be within ± 5 F of the superheat chart value.

4. Repeat steps 1 through 4 for each refrigerant circuit.
5. To stop the SERVICE TEST, turn the main power disconnect switch to the "Off" position or proceed to the next component start-up procedure. Remove electro mechanical test mode connections (if applicable).

Start Up

Heating Start-Up

Gas Heat Units

Open the main disconnect switch to shut the unit off and to reset the RTRM.

Follow the Test Guide in Table 6 to start the unit in the heating mode. ReliaTel Control Momentarily jump across the Test 1 & Test 2 terminals on LTB1 one additional time if continuing from previous component start-up or until the desired start-up component Test is started.

Dehumidification Option

Momentarily jump across the Test 1 and Test 2 terminals of the LTB1 until the unit enters test mode 7. (See Table 6.) Once the unit is in the reheat test mode, verify that the 3 way valve has shifted to the reheat position and that the supply temperature rises 10 deg F more than when in cooling mode stage 2. Monitor the suction pressure for 15 minutes. The suction pressure should remain within 5 psi of normal cooling operation.

Final System Setup

After completing all of the pre-start and start-up procedures outlined in the previous sections (i.e., operating the unit in each of its Modes through all available stages of cooling & heating), perform these final checks before leaving the unit:

- [] Program the Night Setback (NSB) panel (if applicable) for proper unoccupied operation. Refer to the programming instructions for the specific panel.
- [] Verify that the Remote panel “System” selection switch, “Fan” selection switch, and “Zone Temperature” settings for automatic operation are correct.
- [] Inspect the unit for misplaced tools, hardware, and debris.
- [] Verify that all exterior panels including the control panel doors and condenser grilles are secured in place.
- [] Close the main disconnect switch or circuit protector switch that provides the supply power to the unit’s terminal block or the unit mounted disconnect switch.

Maintenance

Monthly Maintenance

Before completing the following checks, turn the unit OFF and lock the main power disconnect switch open.

WARNING **Hazardous Voltage!**

Disconnect all electric power, including remote disconnects before servicing. Follow proper lockout/tagout procedures to ensure the power can not be inadvertently energized. Failure to disconnect power before servicing could result in death or serious injury.

Failure to disconnect power before servicing can cause severe personal injury or death.

Filters

- [] Inspect the return air filters. Clean or replace them if necessary. Refer to the unit Service Facts for filter information.

Return Air Smoke Detector Maintenance

Airflow through the unit is affected by the amount of dirt and debris accumulated on the indoor coil and filters. To insure that airflow through the unit is adequate for proper sampling by the return air smoke detector, complete adherence to the maintenance procedures, including recommended intervals between filter changes, and coil cleaning is required.

Periodic checks and maintenance procedures must be performed on the smoke detector to insure that it will function properly. For detailed instructions concerning these checks and procedures, refer to the appropriate section(s) of the smoke detector Installation and Maintenance Instructions provided with the literature package for this unit.

Cooling Season

- [] Check the unit's drain pans and condensate piping to ensure that there are no blockages.
- [] Inspect the evaporator and condenser coils for dirt, bent fins, etc. If the coils appear dirty, clean them according to the instructions described in "Coil Cleaning" later in this section.
- [] Manually rotate the condenser fan(s) to ensure free movement and check motor bearings for wear. Verify that all of the fan mounting hardware is tight.
- [] Inspect the F/A-R/A damper hinges and pins to ensure that all moving parts are securely mounted. Keep the blades clean as necessary.
- [] Verify that all damper linkages move freely; lubricate with white grease, if necessary.
- [] Check supply fan motor bearings; repair or replace the motor as necessary.
- [] Check the fan shaft bearings for wear. Replace the bearings as necessary.
- [] Check the supply fan belt. If the belt is frayed or worn, replace it. Refer to the "Fan Belt Adjustment" section for belt replacement and adjustments.
- [] Verify that all wire terminal connections are tight.
- [] Remove any corrosion present on the exterior surfaces of the unit and repaint these areas.
- [] Generally inspect the unit for unusual conditions (e.g., loose access panels, leaking piping connections, etc.)
- [] Make sure that all retaining screws are reinstalled in the unit access panels once these checks are complete.

- [] With the unit running, check and record the: ambient temperature; compressor suction and discharge pressures (each circuit); superheat (each circuit);

Record this data on an "operator's maintenance log" like the one shown in Table 7. If the operating pressures indicate a refrigerant shortage, measure the system superheat. For guidelines, refer to the "Compressor Start-Up" section.

Note: Do Not release refrigerant to the atmosphere! If adding or removing refrigerant is required, the service technician must comply with all federal, state and local laws.

Heating Season

- [] Inspect the unit's air filters. If necessary, clean or replace them.
- [] Check supply fan motor bearings; repair or replace the motor as necessary.
- [] Inspect both the main unit control panel and heat section control box for loose electrical components and terminal connections, as well as damaged wire insulation. Make any necessary repairs.
- [] Clean burner area, verify gas heat system operates properly.

Coil Cleaning

Regular coil maintenance, including annual cleaning, enhances the unit's operating efficiency by minimizing: compressor head pressure and amperage draw; evaporator water carryover; fan brake horsepower, due to increase static pressure losses; airflow reduction.

At least once each year, or more often if the unit is located in a "dirty" environment, clean the evaporator and condenser coils using the instructions outlined. Be sure to follow these instructions as closely as possible to avoid damaging the coils.

Maintenance

To clean refrigerant coils, use a soft brush and a sprayer (either a garden pump-up type or a high-pressure sprayer). A high-quality detergent is also required; suggested brands include "SPREX A.C.", "OAKITE 161", "OAKITE 166" and "COILOX". If the detergent selected is strongly alkaline (ph value exceeds 8.5), add an inhibitor.

1. Remove enough panels from the unit to gain access to the coil. Remove the access panel from the roof located next to the rear condenser fan.
2. Protect all electrical devices such as motors and controllers from any over spray.
3. Straighten any bent coil fins with a fin comb.
4. Mix the detergent with water according to the manufacturer's instructions. If desired, heat the solution to 150 F maximum to improve its cleansing capability.

WARNING

Hazardous Pressures!

Coils contain refrigerant under pressure. When cleaning coils, maintain coil cleaning solution temperature under 150°F to avoid excessive pressure in the coil. Failure to follow these safety precautions could result in coil bursting, which could result in death or serious injury.

Do not heat the detergent-and-water solution above 150° F. Hot liquids sprayed on the exterior of the coil will raise the coil's internal pressure and may cause it to burst. Failure to follow proper procedures can result in personal illness or injury or severe equipment damage.

5. Pour the cleaning solution into the sprayer. If a high-pressure sprayer is used:
 - a. do not allow sprayer pressure to exceed 600 psi.

- b. the minimum nozzle spray angle is 15 degrees.
- c. maintain a minimum clearance of 6" between the sprayer nozzle and the coil.
- d. spray the solution perpendicular (at 90 degrees) to the coil face.

6. Spray the leaving-airflow side of the coil first; then spray the opposite side of the coil. Allow the cleaning solution to stand on the coil for five minutes.
7. Rinse both sides of the coil with cool, clean water.
8. Inspect both sides of the coil; if it still appears to be dirty, repeat Steps 6 and 7.
9. Reinstall all of the components and panels removed in Step 1 and any protective covers installed in step 2.
10. Restore the unit to its operational status and check system operation.

Final Process

For future reference, you may find it helpful to record the unit data requested below in the blanks provided.

(1) Complete Unit Model Number:

(2) Unit Serial Number:

(3) Wiring Diagram Numbers (from unit control panel)

— schematic(s)

— connection(s)

Maintenance

Table 7
Sample Maintenance Log

Date	Refrigerant Circuit #1							Refrigerant Circuit #2					
	Current Ambient Temp.	Compr. Oil Level	Suct. Press.	Disch. Press.	Liquid Press.	Super-heat	Sub-cool.	Compr. Oil Level	Suct. Press.	Disch. Press.	Liquid Press.	Super-heat	Sub-cool.
	F/C		Psig/kPa	Psig/kPa	Psig/kPa	F/C	F/C		Psig/kPa	Psig/kPa	Psig/kPa	F/C	F/C
		- ok - low						- ok - low					
		- ok - low						- ok - low					
		- ok - low						- ok - low					
		- ok - low						- ok - low					
		- ok - low						- ok - low					
		- ok - low						- ok - low					
		- ok - low						- ok - low					
		- ok - low						- ok - low					
		- ok - low						- ok - low					

Note: Check and record the data requested above each month during the cooling season with the unit running.

Trouble Shooting

ReliaTel Control

The RTRM has the ability to provide the service personnel with some unit diagnostics and system status information.

Before turning the main power disconnect switch “Off”, follow the steps below to check the ReliaTel Refrigeration Module (RTRM). All diagnostics & system status information stored in the RTRM will be lost when the main power is turned “Off”.



WARNING

Hazardous Service Procedures!

The maintenance and troubleshooting procedures recommended in this section of the manual could result in exposure to electrical, mechanical or other potential safety hazards. Always refer to the safety warnings provided throughout this manual concerning these procedures. When possible, disconnect all electrical power including remote disconnects before servicing. Follow proper lock-out/tagout procedures to ensure the power can not be inadvertently energized. When necessary to work with live electrical components, have a qualified licensed electrician or other individual who has been trained in handling live electrical components perform these tasks. Failure to follow all of the recommended safety warnings provided, could result in death or serious injury.

To prevent injury or death from electrocution, it is the responsibility of the technician to recognize this hazard and use extreme care when performing service procedures with the electrical power energized.

1. Verify that the Liteport LED on the RTRM is burning continuously. If the LED is lit, go to Step 3.

2. If the LED is not lit, verify that 24 VAC is present between J1-1 and J1-2.

If 24 VAC is present, proceed to Step 3. If 24 VAC is not present, check the unit main power supply, check transformer (TNS1). Proceed to Step 3 if necessary.

3. Utilizing “Method 1” or “Method 2” in the “System Status Checkout Procedure” section, check the following:

System status
Heating status
Cooling status

If a System failure is indicated, proceed to Step 4. If no failures are indicated, proceed to Step 5.

4. If a System failure is indicated, recheck Steps 1 and 2. If the LED is not lit in Step 1, and 24 VAC is present in Step 2, the RTRM has failed. Replace the RTRM.

5. If no failures are indicated, use one of the TEST mode procedures described in the “Unit Start-Up” section to start the unit. This procedure will allow you to check all of the RTRM outputs, and all of the external controls (relays, contactors, etc.) that the RTRM outputs energize, for each respective mode. Proceed to Step 6.

6. Step the system through all of the available modes, and verify operation of all outputs, controls, and modes. If a problem in operation is noted in any mode, you may leave the system in that mode for up to one hour while troubleshooting. Refer to the sequence of operations for each mode, to assist in verifying proper operation. Make the necessary repairs and proceed to Steps 7 and 8.

7. If no abnormal operating conditions appear in the test mode, exit the test mode by turning the power “Off” at the main power disconnect switch.

8. Refer to the individual component test procedures if other microelectronic components are suspect.

System Status Checkout Procedure

“System Status” is checked by using one of the following two methods:

Method 1

If the Zone Sensor Module (ZSM) is equipped with a remote panel with LED status indication, you can check the unit within the space. If the ZSM does not have LED's, use Method 2. BAYSENS010B, BAYSENS011B, BAYSENS019B, BAYSENS020B, BAYSENS021A & BAYSENS023A all have the remote panel indication feature. The LED descriptions are listed below.

LED 1 (System)

“On” during normal operation.

“Off” if a system failure occurs or the LED fails.

“Flashing” indicates test mode.

LED 2 (Heat)

“On” when the heat cycle is operating.

“Off” when the heat cycle terminates or the LED fails.

“Flashing” indicates a heating failure.

LED 3 (Cool)

“On” when the cooling cycle is operating.

“Off” when the cooling cycle terminates or the LED fails.

“Flashing” indicates a cooling failure.

LED 4 (Service)

“On” indicates a clogged filter.

“Off” during normal operation.

“Flashing” indicates an evaporator fan failure

Below is the complete listing of failure indication causes.

Trouble Shooting

System Failure

Check the voltage between terminals 6 and 9 on J6, it should read approximately 32 VDC. If no voltage is present, a System failure has occurred. Refer to Step 4 in the previous section for the recommended troubleshooting procedure.

Heating Failure

Verify Heat Failure by Ignition Module (IGN) LED indicator:

OFF:	No Power or Failure
ON:	Normal
Slow Flash:	Normal, Heat Call
Fast Flash:	Error Code:
1 Flash:	Communication Failure
2 Flashes:	System Lockout
4 Flashes:	TC01 or TC02 Open
5 Flashes:	Flame w/o Gas Valve

Cooling Failure

1. Cooling and heating set point (slide pot) on the zone sensor has failed. Refer to the "Zone Sensor Test Procedure" section.
2. Zone temperature thermistor ZTEMP on ZTS failed. Refer to the "Zone Sensor Test Procedure" section.
3. CC1 or CC2 24 VAC control circuit has opened, check CC1 & CC2 coils, and any of the controls below that apply to the unit (HPC1, HPC2).
4. LPC1 has opened during the 3 minute minimum "on time" during 4 consecutive compressor starts, check LPC1 or LPC2 by testing voltage between the J1-8 & J3-2 terminals on the RTRM and ground. If 24 VAC is present, the LPC's has not tripped. If no voltage is present, LPC's has tripped.

Service Failure

1. If the supply fan proving switch has closed, the unit will not operate (when connected to RTOM), check the fan motor, belts, and proving switch.
2. Clogged filter switch has closed, check the filters.

Simultaneous Heat and Cool Failure

1. Emergency Stop is activated.

Method 2

The second method for determining system status is done by checking voltage readings at the RTRM (J6). The system indication descriptions and the approximate voltages are listed below.

System Failure

Measure the voltage between terminals J6-9 & J6-6.
Normal Operation = approximately 32 VDC
System Failure = less than 1 VDC, approximately 0.75 VDC
Test Mode = voltage alternates between 32 VDC & 0.75 VDC

Heat Failure

Measure the voltage between terminals J6-7 & J6-6.
Heat Operating = approximately 32 VDC
Heat Off = less than 1 VDC, approximately 0.75 VDC
Heating Failure = voltage alternates between 32 VDC & 0.75 VDC

Cool Failure

Measure the voltage between terminals J6-8 & J6-6.
Cool Operating = approximately 32 VDC
Cool Off = less than 1 VDC, approximately 0.75 VDC
Cooling Failure = voltage alternates between 32 VDC & 0.75 VDC

Service Failure

Measure the voltage between terminals J6-10 & J6-6.
Clogged Filter = Approximately 32 VDC.
Normal = Less than 1 VDC, approximately 0.75 VDC.

Fan Failure = voltage alternates between 32 VDC & 0.75 VDC.

To use LED's for quick status information at the unit, purchase a BAYSENS010B ZSM and connect wires with alligator clamps to terminals 6 through 10. Connect each respective terminal wire (6 through 10) from the Zone Sensor to the unit J6 terminals 6 through 10.

Note: If the system is equipped with a programmable zone sensor, (BAYSENS019A, BAYSENS020A or BAYSENS023A), the LED indicators will not function while the BAYSENS010A is connected.

Resetting Cooling and Heating Lockouts

Cooling Failures and Heating Lockouts are reset in an identical manner. Method 1 explains resetting the system from the space; Method 2 explains resetting the system at the unit.

Note: Before resetting Cooling Failures and Heating Lockouts check the Failure Status Diagnostics by the methods previously explained. Diagnostics will be lost when the power to the unit is disconnected.

Trouble Shooting

Method 1

To reset the system from the space, turn the “Mode” selection switch at the zone sensor to the “Off” position. After approximately 30 seconds, turn the “Mode” selection switch to the desired mode, i.e. Heat, Cool or Auto.

Method 2

To reset the system at the unit, cycle the unit power by turning the disconnect switch “Off” and then “On”.

Lockouts can be cleared through the building management system. Refer to the building management system instructions for more information.

Zone Temperature Sensor (ZTS) Service Indicator

The ZSM SERVICE LED is a generic indicator, that will signal the closing of a Normally Open switch at any time, providing the Indoor Motor (IDM) is operating. This indicator is usually used to indicate a clogged filter, or an air side fan failure.

The RTRM will ignore the closing of this Normally Open switch for 2 (±1) minutes. This helps prevent nuisance SERVICE LED indications. The exception is the LED will flash 40 seconds after the fan is turned “On” if the Fan Proving Switch is not made.

Clogged Filter Switch

This LED will remain lit the entire time that the Normally Open switch is closed. The LED will be turned off immediately after resetting the switch (to

the Normally Open position), or any time that the IDM is turned “Off”.

If the switch remains closed, and the IDM is turned “On”, the SERVICE LED will be turned “On” again after the 2 (±1) minute ignore delay.

This LED being turned “On”, will have no other affect on unit operation. It is an indicator only.

Fan Failure Switch

When the “Fan Failure” switch is wired to the RTOM, the LED will remain flashing the entire time the fan proving switch is closed, indicating a fan failure, and it will shut the unit operations down.

Zone Temperature Sensor (ZTS) Test

Note: These procedures are not for programmable or digital models and are conducted with the Zone Sensor Module electrically removed from the system.

Test 1 Zone Temperature Thermistor (ZTEMP)

This component is tested by measuring the resistance between terminals 1 and 2 on the Zone Temperature Sensor. Below are some typical indoor temperatures, and corresponding resistive values.

Zone Temperature		Nominal ZTEMP Resistance
50 F°	10.0 C	19.9 K-Ohms
55 F	12.8 C	17.47 K-Ohms
60 F	15.6 C	15.3 K-Ohms
65 F	18.3 C	13.49 K-Ohms
70 F	21.1 C	11.9 K-Ohms
75 F	23.9 C	10.50 K-Ohms
80 F	26.7 C	9.3 K-Ohms
85 F	29.4 C	8.25 K-Ohms
90 F	32.2 C	7.3 K-Ohms

Test 2

Cooling Set Point (CSP) and Heating Set Point (HSP)

The resistance of these potentiometers are measured between the following ZSM terminals. Refer to the chart above for approximate resistances at the given setpoints.

Cool SP = Terminals 2 and 3

Range = 100 to 900 Ohms approximate

Heat SP = Terminals 2 and 5

Range = 100 to 900 Ohms approximate

Trouble Shooting

Test 3 System Mode and Fan Selection

The combined resistance of the Mode selection switch and the Fan selection switch can be measured between terminals 2 and 4 on the Zone Sensor. The possible switch combinations are listed below with their corresponding resistance values.

Resistance Valves (Ohms)	Zone Sensor Unit/Fan Mode	Local Unit Mode	Local Fan Mode
2.32K	Off/ Auto	Off	Auto
4.87K	Cool/Auto	Cool	Auto
7.68K	Auto/Auto	Auto	Auto
10.77K	Off/On	Off	On
13.32K	Cool/On	Cool	On
16.13K	Auto/On	Auto	On
19.48K	Heat/Auto	Heat	Auto
27.93K	Heat/On	Heat	On
35.0K	Emergency Heat/Auto	Emergency Heat	Auto
43.45K	Emergency Heat/On	Emergency Heat	On
Out of Range (Short)	INVALID/Short	Invalid (CV), Auto (VAV)	Invalid
Out of Range (Open)	INVALID/Open	Invalid (CV), Off (VAV)	Invalid

Test 4 LED Indicator Test, (SYS ON, HEAT, COOL & SERVICE)

Method 1

Testing the LED using a meter with diode test function. Test both forward and reverse bias. Forward bias should measure a voltage drop of 1.5 to 2.5 volts, depending on your meter. Reverse bias will show an Over Load, or open circuit indication if LED is functional.

Method 2

Testing the LED with an analog Ohmmeter. Connect Ohmmeter across LED in one direction, then reverse the leads for the opposite direction. The LED should have at least 100 times more resistance in reverse direction, as compared with the forward direction. If high resistance in both directions, LED is open. If low in both directions, LED is shorted.

Method 3

To test LED's with ZSM connected to unit, test voltages at LED terminals on ZSM. A measurement of 32 VDC, across an unlit LED, means the LED has failed.

Note: Measurements should be made from LED common (ZSM terminal 6 to respective LED terminal). Refer to the Zone Sensor Module (ZSM) Terminal Identification table at the beginning of this section.

Trouble Shooting

Programmable & Digital Zone Sensor Test

Testing serial communication voltage

1. Verify 24 VAC is present between terminals J6-14 & J6-11 on the RTRM.
2. Disconnect wires from J6-11 and J6-12. Measure the voltage between J6-11 and J6-12, should be about 32 VDC.
3. Reconnect wires to terminals J6-11 and J6-12. Measure voltage again between J6-11 and J6-12, voltage should flash high and low every 0.5 seconds. The voltage on the low end will measure about 19 VDC, while the voltage on the high end will measure from approximately 24 to 38 VDC.
4. Verify all modes of operation, by running the unit through all of the steps in the "Test Modes" section discussed in "Unit Start-Up".
5. After verifying proper unit operation, exit the test mode. Turn the fan on continuously at the ZSM, by pressing the button with the fan symbol. If the fan comes on and runs continuously, the ZSM is good. If you are not able to turn the fan on, the ZSM is defective.

ReliaTel Refrigeration Module (RTRM) Default Chart

If the RTCI loses input from the building management system, the RTRM will control in the default mode after approximately 15 minutes. If the RTRM loses the Heating and Cooling setpoint input, the RTRM will control in the default mode instantaneously. The temperature sensing thermistor in the Zone Sensor Module is the only component required for the "Default Mode" to operate.

Unit Operation without a Zone Sensor

This procedure is for temporary operation only. The economizer and condenser fan cycling functions are disabled.

1. Open and Lock the unit disconnect switch.
2. Remove the Outside Air Sensor (OAS) from the condenser section of unit.
3. Use two (2) wire nuts, to individually cap the wires.
4. Locate the RTRM (J6). Connect two (2) wires to terminals J6-1 and 2.
5. Connect the sensor (OAS) using two wire nuts to the two (2) field supplied wires that were connected to terminals 1 and 2 on J6.

Unit Economizer Control (ECA) Troubleshooting ReliaTel Control

Verify Economizer Status by Economizer Actuator (ECA) LED indicator:

OFF:	No Power or Failure
ON:	Normal, OK to Economize
Slow Flash:	Normal, Not OK to Economize
Fast Flash -	1/2 Second On / 2 Seconds Off:
	Error Code:
	Communications Failure
Pulse Flash:	2 Seconds On / 1/2 Second Off:
	Error Code:
1 Flash:	Actuator Fault
2 Flashes:	CO2 Sensor
3 Flashes:	RA Humidity Sensor
4 Flashes:	RA Temp Sensor
5 Flashes:	OA Quality Sensor
6 Flashes:	OA Humidity Sensor
7 Flashes:	OA Temp Sensor
8 Flashes:	MA Temp Sensor
9 Flashes:	RAM Fault
10 Flashes:	ROM Fault
11 Flashes:	EEPROM Fault

Warranty

Combination Gas Electric Air Conditioner YCC, YCD, YCH, YCP, YSC and YHC (Parts Only)

Models Less Than 20 Tons for Residential Use*

This limited warranty is extended by American Standard Inc., to the original purchaser and to any succeeding owner of the real property to which the Combination Gas Electric Air Conditioner is originally affixed, and applies to products purchased and retained for use within the U.S.A. and Canada.

If any part of your Combination Gas Electric Air Conditioner fails because of a manufacturing defect within five years from the date of the original purchase, Warrantor will furnish without charge the required replacement part. Any local transportation, related service labor, diagnosis calls, air filters, refrigerant and related items are not included. If the sealed motor-compressor fails because of a manufacturing defect within five years from the date of original purchase, Warrantor will furnish without charge the required replacement compressor. Any local transportation, related service labor, diagnosis calls, refrigerant and related items are not included.

In addition, if the steel heat exchanger fails because of a manufacturing defect within the sixth through twentieth year from the date of original purchase, Warrantor will furnish without charge a replacement heat exchanger. Any local transportation, related service labor and diagnosis calls are not included.

This limited warranty does not cover failure of your combination gas electric air conditioner if it is damaged while in your possession, failure attributable or caused by unreasonable use of the combination gas electric air conditioner and/or failure to properly maintain the combination gas electric air conditioner as set forth in the Use and Care manual. This limited warranty applies to product installed on or after 10/1/2001 where product is manufactured after 1/1/2000. This limited warranty is not retroactive to any installations prior to 10/1/2001 or on product produced prior to 2000.

THE LIMITED WARRANTY AND LIABILITY SET FORTH HEREIN ARE IN LIEU OF ALL OTHER WARRANTIES AND LIABILITIES, WHETHER IN CONTRACT OR IN NEGLIGENCE, EXPRESS OR IMPLIED, IN LAW OR IN FACT, INCLUDING IMPLIED WARRANTIES OF MERCHANTABILITY AND FITNESS FOR PARTICULAR USE, AND IN NO EVENT SHALL WARRANTOR BE LIABLE FOR ANY INCIDENTAL OR CONSEQUENTIAL DAMAGES.

Some states do not allow limitations on how long an implied limited warranty lasts or do not allow the exclusion or limitation of incidental or consequential damages, so the above limitation or exclusion may not apply to you. This limited warranty gives you specific legal rights, and you may also have other rights which vary from state to state. Parts will be provided by our factory organization through an authorized service organization in your area listed in the yellow pages. If you wish further help or information concerning this limited warranty, contact:

American Standard Inc.
2701 Wilma Rudolph Blvd.
Clarksville, TN 37040-1008
Attention: Manager, Product Service

GW-618-4001

* This limited warranty is for residential usage of this equipment and not applicable when this equipment is used for a commercial application. A commercial use is any application where the end purchaser uses the product for other than personal, family or household purposes.

Warranty

Standard Equipment Warranty Terms and Conditions Commercial Equipment Warranty and Liability Models Larger than 20 Tons for Commercial Use*

The Company warrants for a period of 12 months from initial start-up or 18 months from date of shipment, whichever is less, that the Company products covered by this order (1) are free from defects in material and workmanship and (2) have the capacities and ratings set forth in the Company's catalogs and bulletins, provided that no warranty is made against corrosion, erosion or deterioration. The Company's obligations and liabilities under this warranty are limited to furnishing f.o.b. factory or warehouse at Company designated shipping point, freight allowed to Buyer's city (or port of export for shipment outside the conterminous United States) replacement equipment (or at the option of the Company parts therefore) for all Company products not conforming to this warranty and which have been returned to the manufacturer. The Company shall not be obligated to pay for the cost of lost refrigerant. No liability whatever shall attach to the Company until said products have been paid for and then said liability shall be limited to the purchase price of the equipment shown to be defective.

The Company makes certain further warranty protection available on an optional extra-cost basis. Any further warranty must be in writing, signed by an officer of the Company.

The warranty and liability set forth herein are in lieu of all other warranties and liabilities, whether in contract or in negligence, express or implied, in law or in fact, including implied warranties of merchantability and fitness for particular use. In no event shall the Company be liable for any incidental or consequential damages.

American Standard Inc.
2701 Wilma Rudolph Blvd.
Clarksville, TN 37040-1008
Attention: Manager, Product Service



Literature Order Number	YC-IOM-13
File Number	SV-UN-RT-YC-IOM-13 12/04
Supersedes	YC-IOM-13 4/03
Stocking Location	