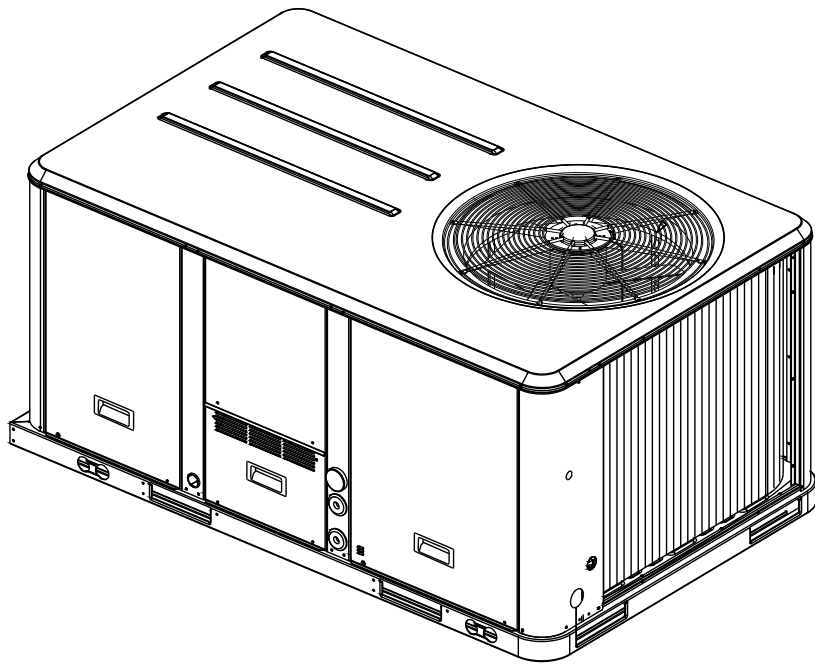


# Installation Operation and Maintenance

---

## Packaged Gas/Electric

*3 - 10 Ton*



**Model Numbers:**

YSC036A - YSC120A  
YHC033A - YHC120A  
YSC036E - YSC060E

YHC036E - YHC060E  
YSC072 - YSC120E

---

February 2009

RT-SVX21F-EN

# Preface and Warnings and Cautions

## Hazard Identification

Warnings and Cautions appear at appropriate sections throughout this manual. Read these carefully.

### WARNING

Indicates a potentially hazardous situation which, if not avoided, could result in death or serious injury.

### CAUTION

Indicates a potentially hazardous situation which, if not avoided, could result in minor or moderate injury. It may also be used to alert against unsafe practices.

### NOTICE

Indicates a situation that could result in equipment or property-damage-only accidents.

## Unit Inspection

As soon as the unit arrives at the job site

- Verify that the nameplate data matches the data on the sales order and bill of lading (including electrical data).
- Verify that the power supply complies with the unit nameplate specifications.
- Visually inspect the exterior of the unit, including the roof, for signs of shipping damage.

If the job site inspection of the unit reveals damage or material shortages, file a claim with the carrier immediately. Specify the type and extent of the damage on the "bill of lading" before signing.

- Visually inspect the internal components for shipping damage as soon as possible after delivery and before it is stored. Do not walk on the sheet metal base pans.
- If concealed damage is discovered, notify the carrier's terminal of damage immediately by phone and by mail. Concealed damage must be reported within 15 days.

- Request an immediate joint inspection of the damage by the carrier and the consignee. Do not remove damaged material from the receiving location. Take photos of the damage, if possible. The owner must provide reasonable evidence that the damage did not occur after delivery.
- Notify the appropriate sales representative before installing or repairing a damaged unit.

## Storage

Take precautions to prevent condensate from forming inside the unit's electrical compartments and motors if:

1. the unit is stored before it is installed; or,
2. the unit is set on the roof curb, and temporary heat is provided in the building. Isolate all side panel service entrances and base pan openings (e.g., conduit holes, S/A and R/A openings, and flue openings) from the ambient air until the unit is ready for start-up.

**Note:** Do not use the unit's heater for temporary heat without first completing the start-up procedure detailed under "Starting the Unit."

The manufacturer will not assume any responsibility for equipment damage resulting from condensate accumulation on the unit's electrical and/or mechanical components.

## Model Number Description

All products are identified by a multiple-character model number that precisely identifies a particular type of unit. Its use will enable the owner/operator, installing contractors, and service engineers to define the operation, specific components, and other options for any specific unit.

When ordering replacement parts or requesting service, be sure to refer to the specific model number and serial number printed on the unit nameplate.

## Overview of Manual

**Note:** One copy of this document ships inside the control panel of each unit and is customer property. It must be retained by the unit's maintenance personnel.

This booklet describes proper installation, operation, and maintenance procedures for air cooled systems. By carefully reviewing the information within this manual and following the instructions, the risk of improper operation and/or component damage will be minimized.

It is important that periodic maintenance be performed to help assure trouble free operation. A maintenance schedule is provided at the end of this manual. Should equipment failure occur, contact a qualified service organization with qualified, experienced HVAC technicians to properly diagnose and repair this equipment.

### WARNING Contains Refrigerant!

System contains oil and refrigerant under high pressure. Recover refrigerant to relieve pressure before opening the system. See unit nameplate for refrigerant type. Do not use non-approved refrigerants, refrigerant substitutes, or refrigerant additives.

Failure to follow proper procedures or the use of non-approved refrigerants, refrigerant substitutes, or refrigerant additives could result in death or serious injury or equipment damage.

### WARNING Hazardous Voltage w/ Capacitors!

Disconnect all electric power, including remote disconnects and discharge all motor start/run capacitors before servicing. Follow proper lockout/tagout procedures to ensure the power cannot be inadvertently energized. Verify with an appropriate voltmeter that all capacitors have discharged. Failure to disconnect power and discharge capacitors before servicing could result in death or serious injury.

## Preface and Warnings and Cautions

---

### **WARNING**

#### **R410a Refrigerant under Higher Pressure than R-22!**

R-410A refrigerant systems operate at higher pressures than standard R-22 systems. Do not use R-22 service equipment or components on R-410A refrigerant equipment. Using service equipment not rated for R-410A could result in the equipment exploding under higher pressure which could result in death or serious injury.

### **WARNING**

#### **Equipment Damage From Ultraviolet (UV) Lights!**

The manufacturer does not recommend field installation of ultraviolet lights in its equipment for the intended purpose of improving indoor air quality. High intensity C-band ultraviolet light is known to severely damage polymer (plastic) materials and poses a personal safety risk to anyone exposed to the light without proper personal protective equipment. Polymer materials commonly found in HVAC equipment that may be susceptible include insulation on electrical wiring, fan belts, thermal insulation, various fasteners and bushings. Degradation of these materials could result in serious damage to the equipment.

The manufacturer accepts no responsibility for the performance or operation of our equipment in which ultraviolet devices were installed outside of the manufacturer's factory or its approved suppliers.

### **NOTICE**

#### **Roof Damage!**

System contains oil and refrigerant under high pressure. Roofs should be protected from exposure to oils and refrigerant in the system. If rooftop is not protected damage to the roof could occur.

# Contents

---

Hazard Identification	2
Unit Inspection	2
Storage	2
Overview of Manual	2
<b>Model Number Description</b>	<b>6</b>
<b>General Information</b>	<b>8</b>
Unit Clearances	12
<b>Unit Dimensions</b>	<b>12</b>
<b>Pre-Installation</b>	<b>15</b>
<b>Installation</b>	<b>16</b>
Foundation	18
Roof Curb	19
General Unit Requirements	20
Horizontal Discharge Conversion	21
TCO-1 Instructions:	22
Horizontal Discharge Conversion	22
Return Air Smoke Detector	23
Through the Base Gas Installation	24
Requirements for Gas Heat	25
Filter Installation	26
Field Installed Power Wiring	26
Main Unit Power	26
Main Unit Power	26
Controls using DC Analog Input/Outputs	27
Smoke Detector	
Customer Low Voltage Wiring	30
Space Temperature Averaging	31
Voltage Imbalance	34
Electrical Phasing	34
<b>Pre-Start</b>	<b>34</b>
Test Modes	36
Verifying Proper Air Flow	37
ReliaTel™ Control	37
Electro Mechanical Control	37
Verifying Proper Air Flow	37
<b>Start-Up</b>	<b>37</b>
Verifying Proper Air Flow	38
Return Air Smoke Detector	39
Economizer Start-Up	39
Compressor Start-Up	39
Final System Setup	40
Fan Belt Adjustment - Belt Drive Units	41
Monthly Maintenance	41
Filters	41

# Contents

---

<b>Maintenance</b> .....	41
Annual Maintenance .....	44
Final Process .....	44
ReliaTel™ Control .....	45
System Status Checkout Procedure .....	45
<b>Trouble Shooting</b> .....	45
Resetting Cooling and Ignition Lockouts .....	46
Zone Temperature Sensor (ZTS) Service Indicator .....	46
Clogged Filter Switch .....	47
Fan Failure Switch .....	47
Zone Temperature Sensor (ZTS) Test .....	47
Unit Economizer Control (ECA) Troubleshooting .....	48
Resetting Cooling and Ignition Lockouts .....	49
Unit Economizer Control (ECA) Test Procedures .....	49
<b>Wiring Diagrams</b> .....	50
Combination Gas Electric Air Conditioner .....	52
<b>Limited Warranty</b> .....	52
Combination Gas Electric Air Conditioner .....	53

# Model Number Description

**Y H C 033 A 3 R B A \*\* C 0 0 0 A 1 0 0 0 1 A 1**  
**1 2 3 456 7 8 9 10 11 12,13 14 15 16 17 18 19 20 21 22 23 24 25**

## DIGIT 1 – UNIT TYPE

T DX Cooling  
 Y DX Cooling, Gas Heat  
 W Packaged Heat Pump<sup>2</sup>

## DIGIT 2 – EFFICIENCY

S Standard Efficiency  
 H High Efficiency

## DIGIT 3 – AIRFLOW

C Convertible

## DIGIT 4,5,6 – NOMINAL GROSS COOLING CAPACITY (MBh)

033 3 Ton  
 036 3 Tons  
 043 4 Ton  
 048 4 Tons  
 060 5 Tons  
 063 5 Ton  
 072 6 1/4 Ton  
 090 7 1/2 Ton (Single Compressor)  
 092 7 1/2 Ton (Dual Compressor)  
 102 8 1/2 Ton  
 120 10 Ton

## DIGIT 7 – MAJOR DESIGN SEQUENCE

A R-22 Refrigerant  
 E R-410A Refrigerant

## DIGIT 8 – VOLTAGE SELECTION

1 208-230/60/1  
 3 208-230/60/3  
 4 460/60/3  
 D 380-415/50/3  
 K 380/60/3  
 T 200/50/3

## W = 575/60/3 DIGIT 9 – UNIT CONTROLS

E Electromechanical<sup>1</sup>  
 R ReliaTel™ Microprocessor

## DIGIT 10 – HEATING CAPACITY

0=No Electric Heat E=12 kW (3 phase)  
 A=5 kW (1 phase)<sup>2</sup> F=14 kW (1 phase)<sup>2</sup>  
 B=6 kW (3 phase) G=18 kW (1&3 phase)  
 D=10 kW (1 phase)<sup>2</sup> J=23 kW (3 phase)

**Note:** Applicable to Digit 1, Y models only.

L Low  
 M Medium

H High  
 X Low, Stainless Steel Heat Exchanger  
 Y Medium, Stainless Steel Heat Exchanger  
 Z High, Stainless Steel Heat Exchanger

## DIGIT 11 – MINOR DESIGN SEQUENCE

A First Sequence

## DIGIT 12,13 – SERVICE SEQUENCE

\*\* Factory Assigned

## DIGIT 14 – FRESH AIR SELECTION

0 No Fresh Air  
 A Manual Outside Air Damper 0-50%<sup>5</sup>  
 B Motorized Outside Air Damper 0-50%  
 C Economizer, Dry Bulb 0-100% without Barometric Relief<sup>8</sup>  
 D Economizer, Dry Bulb 0-100% with Barometric Relief<sup>8</sup>  
 E Economizer, Reference Enthalpy 0-100% without Barometric Relief<sup>4,8</sup>  
 F Economizer, Reference Enthalpy 0-100% with Barometric Relief<sup>4,8</sup>  
 G Economizer, Comparative Enthalpy 0-100% without Barometric Relief<sup>4,8</sup>  
 H Economizer, Comparative Enthalpy 0-100% with Barometric Relief<sup>4,8</sup>

## DIGIT 15 - SUPPLY FAN/DRIVE TYPE/MOTOR

0 Standard Drive<sup>7</sup>  
 2) Optional Belt Drive Motor<sup>20</sup>

## DIGIT 16 - HINGED SERVICE ACCESS/FILTERS

0 Standard Panels/Standard Filters  
 A Hinged Access Panels/Standard Filters  
 B Standard Panels with 2-inch MERV 7 pleated filter  
 C Hinged Access Panels with 2-inch MERV 7 pleated filter  
 D Standard Panels with 2-inch MERV 13 pleated filter  
 E Hinged Access Panels with 2-inch MERV 13 pleated filter

## DIGIT 17 - CONDENSER COIL PROTECTION

0 Standard Coil  
 1 Standard Coil with Hail Guard  
 2 Black Epoxy Pre-Coated Condenser Coil  
 3 Black Epoxy Pre-Coated Condenser Coil with Hail Guard  
 4 CompleteCoat™ Condenser Coil  
 5 CompleteCoat™ Condenser Coil with Hail Guard

## DIGIT 18 - THROUGH THE BASE PROVISIONS

**Note:** (Applicable to Digit 1, T or Y models)

0 No Through the Base Provisions  
 A Through the Base Electric<sup>9</sup>

**Note:** (Applicable to Digit 1, Y models only)

B Through the Base Gas Piping  
 C Through the Base Electric and Gas Piping<sup>17</sup>

## DIGIT 19 - DISCONNECT/CIRCUIT BREAKER/PHASE MONITOR (THREE- PHASE ONLY)

0 No Disconnect / No Circuit Breaker  
 1 Unit Mounted Non-Fused Disconnect  
 2 Unit Mounted Circuit Breaker

## DIGIT 20 - CONVENIENCE OUTLET

0 No Convenience Outlet  
 A Unpowered Convenience Outlet  
 B Powered Convenience Outlet (three-phase only)<sup>10</sup>

## DIGIT 21 - COMMUNICATIONS OPTIONS<sup>4</sup>

0 No Communications Interface  
 1 Trane Communications Interface  
 2 LonTalk® Communications Interface  
 3 Novar 2024 Controls<sup>1</sup>  
 4 Novar 3051 Controls<sup>1</sup> without Zone Sensor<sup>21</sup>

## DIGIT 22 - REFRIGERATION SYSTEM OPTION

0 Standard Refrigeration System<sup>11</sup>  
 A Expansion Valve (standard for 3-

## Model Number Description

---

- 10 Ton R410a Units)
- B Standard Refrigeration System (not yet available for 3-10 Ton R410a Units)

### **DIGIT 23 - REFRIGERATION CONTROLS**

**Note:** Applicable to Digit 7 = A

- 0 No Refrigeration Control<sup>6</sup>
- 2 Froststat<sup>12</sup>
- 3 Crankcase Heater<sup>3</sup>
- 6 Froststat<sup>12</sup> and Crankcase Heater<sup>3</sup>

**Note:** Applicable to Digit 7 = E

- 0 No Refrigeration Control<sup>6</sup>
- 1 Froststat<sup>12</sup>
- 2 Crankcase Heater<sup>3</sup>
- 3 Froststat<sup>12</sup> and Crankcase Heater<sup>3</sup>

### **DIGIT 24 - SMOKE DETECTOR<sup>4,18</sup>**

- 0 No Smoke Detector
- A Return Air Smoke Detector<sup>13,14</sup>
- B Supply Air Smoke Detector
- C Supply and Return Air Smoke Detectors<sup>13,14</sup>

### **DIGIT 25 - MONITORING CONTROLS<sup>4</sup>**

- 0 No Monitoring Control<sup>15</sup>
- 1 Clogged Filter Switch<sup>15</sup>
- 2 Fan Failure Switch<sup>15</sup>
- 3 Discharge Air Sensing Tube<sup>15</sup>
- 4 Clogged Filter Switch and Fan Fail Switch<sup>15</sup>
- 5 Clogged Filter Switch and Discharge Air Sensing Tube<sup>15</sup>
- 6 Fan Fail Switch and Discharge Air Sensing Tube<sup>15</sup>
- 7 Clogged Filter and Fan Fail Switches and Discharge Air Sensing Tube<sup>15</sup>
- 8 Novar Return Air Sensor<sup>16</sup>
- 9 Novar Zone Sensor<sup>21</sup>

### **Model Number Notes**

1. Not available with Heat Pumps.
2. Available for R-410A units only.
3. Standard on all 15 SEER and 4-5 Tons Heat Pump R-22 units.
4. Not available with electromechanical controls.
5. Manual outside air damper will ship factory supplied within the unit, but must be field installed.
6. High pressure control is standard on all units.
7. Multispeed direct drive standard on single-phase and 15 SEER products. Belt drive standard on three-phase 13 SEER and 6-10 ton R410a products.

8. Economizer with Barometric Relief is for down flow configured units only. Order Economizer without Barometric Relief for horizontal configuration. Barometric Relief for horizontal configured units must be ordered as field installed accessory.
9. Through the base electric required when ordering disconnect/circuit breaker options.
10. Requires use of Disconnect or Circuit Breaker.
11. Standard metering devices are TXVs.
12. Froststat cannot be field installed in electro-mechanical units.
13. The return air smoke detector may not fit up or work properly on the Precedent units when used in conjunction with 3rd party accessories such as bolt on heat wheels, economizers and power exhaust. Do not order the return air smoke detectors when using this type of accessory.
14. Return Air Smoke Detector cannot be ordered with Novar Controls.
15. These options are standard when ordering Novar Controls.
16. This option is used when ordering Novar Controls.
17. Includes gas piping and shutoff (field assembly required).
18. Not available with high temperature stat accessory.
19. Requires hinged access panels.
20. Belt Drive Optional on three-phase 15 SEER, R-410A units.
21. Novar Sensor utilized with digit 21 = (4) Novar 3051 Controls without Zone Sensor.

# General Information

---

## Unit Nameplate

A Mylar unit nameplate is located on the unit's corner support next to the filter access panel. It includes the unit model number, serial number, electrical characteristics, refrigerant charge, as well as other pertinent unit data.

## Compressor Nameplate

The nameplate for the compressors are located on the side of the compressor.

## Unit Description

Before shipment, each unit is leak tested, dehydrated, charged with refrigerant and compressor oil, and run tested for proper control operation.

The condenser coils are aluminum fin, mechanically bonded to copper tubing.

Direct-drive, vertical discharge condenser fans are provided with built-in thermal overload protection.

There are two control systems offered for these units. The electro mechanical control option uses a thermostat to perform unit functions. The ReliaTel™ Control Module is a microelectronic control system that is referred to as "Refrigeration Module" (RTRM). The acronym RTRM is used extensively throughout this document when referring to the control system network.

These modules through Proportional/Integral control algorithms perform specific unit functions that governs unit operation in response to; zone temperature, supply air temperature, and/or humidity conditions depending on the application. The stages of capacity control for these units are achieved by starting and stopping the compressors.

The RTRM is mounted in the control panel and is factory wired to the respective internal components. The RTRM receives and interprets information from other unit modules, sensors, remote panels,

and customer binary contacts to satisfy the applicable request for cooling.

## Economizer Control Actuator (Optional)

### Electro Mechanical Control

The ECA monitors the mixed air temperature, ambient dry bulb temperature and local minimum position setpoint sensors, if selected, to control dampers to an accuracy of +/- 5% of stroke. The actuator is spring returned to the closed position any time that power is lost to the unit. It is capable of delivering up to 25 inch pounds of torque and is powered by 24 VAC.

### ReliaTel™ Control

The ECA monitors the mixed air temperature, return air temperature, minimum position setpoint (local or remote), power exhaust setpoint, CO<sub>2</sub> setpoint, CO<sub>2</sub>, and ambient dry bulb/enthalpy sensor or comparative humidity (return air humidity against ambient humidity) sensors, if selected, to control dampers to an accuracy of +/- 5% of stroke. The actuator is spring returned to the closed position any time that power is lost to the unit. It is capable of delivering up to 25 inch pounds of torque and is powered by 24 VAC.

## RTCI - ReliaTel™ Trane Communication Interface (Optional)

This module is used when the application calls for an ICSTM building management type control system. It allows the control and monitoring of the system through an ICS panel. The module can be ordered from the factory or ordered as a kit to be field installed. Follow the installation instruction that ships with each kit when field installation is necessary.

## RLCI - ReliaTel™ LonTalk Communication Interface (Optional)

This module is used when the application calls for an ICSTM building management type control system that is LonTalk. It allows the control and monitoring of the system through an ICS panel. The module can be ordered from the factory or ordered as a kit to be field installed. Follow the installation instruction that ships with each kit when field installation is necessary.

## RTOM - ReliaTel™ Options Module (Optional)

The RTOM monitors the supply fan proving, clogged filter, supply air temperature, exhaust fan setpoint, supply air tempering, Froststat™ and smoke detector. Refer to system input devices and functions for operation.

## System Input Devices & Functions

The RTRM must have a zone sensor or thermostat input in order to operate the unit. The flexibility of having several mode capabilities depends upon the type of zone sensor or thermostat selected to interface with the RTRM.

The descriptions of the following basic Input Devices used within the RTRM network are to acquaint the operator with their function as they interface with the various modules. Refer to the unit's electrical schematic for the specific module connections.

The following controls are available from the factory for field installation.

### Supply Fan Failure Input (Optional)

The Fan Failure Switch can be connected to sense indoor fan operation:

FFS (Fan Failure Switch) If air flow through the unit is not proven by the differential pressure switch connected to the RTOM (factory set point 0.07 "w.c.) within 40 seconds

## General Information

---

nominally, the RTRM will shut off all mechanical operations, lock the system out, send a diagnostic to ICS, and the SERVICE output will flash. The system will remain locked out until a reset is initiated either manually or through ICS.

### Clogged Filter Switch (Optional)

The unit mounted clogged filter switch monitors the pressure differential across the return air filters. It is mounted in the filter section and is connected to the RTOM. A diagnostic SERVICE signal is sent to the remote panel if the pressure differential across the filters is at least 0.5" w.c. The contacts will automatically open when the pressure differential across the filters decreases to approximately 0.4" w.c. The clogged filter output is energized when the supply fan is operating and the clogged filter switch has been closed for at least 2 minutes. The system will continue to operate regardless of the status of the filter switch.

**Note:** *On units equipped with factory installed MERV 13 filters, a clogged filter switch with different pressure settings will be installed. This switch will close when the differential pressure is approximately 0.8' w.c. and open when the differential falls to 0.7" w.c.*

### Compressor Disable (CPR1/2)

This input incorporates the low pressure control (LPC) of each refrigeration circuit and can be activated by opening a field supplied contact installed on the LTB.

If this circuit is open before the compressor is started, the compressor will not be allowed to operate. Anytime this circuit is opened for 1 continuous second during compressor operation, the compressor for that circuit is immediately turned "Off". The compressor will not be allowed to restart for a minimum of 3 minutes should the contacts close.

If four consecutive open conditions occur during the first three minutes of operation, the compressor for that circuit will be locked out, a diagnostic communicated to the remote panel

(if installed), and a manual reset will be required to restart the compressor.

### Low Pressure Control

#### ReliaTel Control

When the LPC is opened for 1 continuous second, the compressor for that circuit is turned off immediately. The compressor will not be allowed to restart for a minimum of 3 minutes.

If four consecutive open conditions occur during an active call for cooling, the compressor will be locked out, a diagnostic communicated to ICS™, if applicable, and a manual reset required to restart the compressor. On dual compressor units only the affected compressor circuit is locked out.

#### Electromechanical Control

When the LPC is opened, the compressor for that circuit is turned off immediately. The compressor will restart when the LPC closes.

### High Pressure Control (Optional — except on R-410A units)

#### ReliaTel Control

The high pressure controls are wired in series between the compressor outputs on the RTRM and the compressor contactor coils. If the high pressure control switch opens, the RTRM senses a lack of current while calling for cooling and locks the compressor out.

If four consecutive open conditions occur during an active call for cooling, the compressor will be locked out, a diagnostic communicated to ICS™, if applicable, and a manual reset required to restart the compressor. On dual compressor units only the affected compressor circuit is locked out.

#### Electromechanical Control

When the HPC is opened, the compressor for that circuit is turned off immediately. The compressor will restart when the HPC closes.

### Power Exhaust Control (Optional)

#### ReliaTel Control

The power exhaust fan is started whenever the position of the economizer dampers meets or exceeds the power exhaust setpoint when the indoor fan is on.

With the optional ventilation override accessory, the power exhaust fan is independent of the indoor fan.

The setpoint panel is located in the return air section and is factory set at 25%.

#### Electromechanical Control

The power exhaust fan is started whenever the indoor fan is on and the adjustable damper limit switch DLS is closed.

### Lead/Lag Control (Dual Circuit Only)

#### ReliaTel Control Only

Lead/Lag is a selectable input located on the RTRM. The RTRM is configured from the factory with the Lead/Lag control disabled. To activate the Lead/Lag function, simply cut the wire connected to J3-8 at the RTRM. When it is activated, each time the designated lead compressor is shut off due to the load being satisfied, the lead compressor or refrigeration circuit switches. When the RTRM is powered up, i.e. after a power failure, the control will default to the number one circuit compressor.

### Zone Sensor Module (ZSM) (BAYSENS106\*)

This electronic sensor features three system switch settings (Heat, Cool, and Off) and two fan settings (On and Auto). It is a manual changeover control with single setpoint. (Cooling Setpoint Only)

### Zone Sensor Module (ZSM) (BAYSENS108\*)

This electronic sensor features four system switch settings (Heat, Cool, Auto, and Off) and two fan settings (On and Auto). It is a manual or auto changeover control with dual setpoint capability. It can be used with a remote zone temperature sensor BAYSENS077\*.

### Zone Sensor (BAYSENS110\*)

This electronic sensor features four system switch settings (Heat, Cool, Auto, and Off) and two fan settings (On and Auto) with four system status LED's. It is a manual or auto changeover control with dual setpoint capability. It can be used with a remote zone temperature sensor BAYSENS077\*.

### Wall Mounted Relative Humidity Sensor (BAYSENS036\*)

Field installed, wall mounted humidity sensor is used to control activation of the hot gas reheat dehumidification option. Humidity set points can be selected for relative humidity levels between 40% and 60% by adjusting the DEHUMID setting on the ReliaTel Options Module. See [Figure 29 on page 28](#).

### Duct Mounted Relative Humidity Sensor (BAYSENS037\*)

Field installed, duct mounted humidity sensor is used to control activation of the hot gas reheat dehumidification option. Humidity set points can be selected for relative humidity levels between 40% and 60% by adjusting the DEHUMID setting on the ReliaTel Options Module. See [Figure 29 on page 28](#).

### Programmable Zone Sensor - (BAYSENS119\*)

This 7 day programmable sensor features 2, 3 or 4 periods for Occupied or Unoccupied programming per day. If the power is interrupted, the program is retained in permanent memory. If power is off for an extended period of time, only the clock and day may have to be reset.

The Zone Sensor allows selection of 2, 3 or 4 system modes (Heat, Cool, Auto, and Off), two fan modes (On and Auto). It has dual temperature selection with programmable start time capability.

The occupied cooling set point ranges between 45 and 98 degrees Fahrenheit. The heating set point ranges between 43 and 96 degrees Fahrenheit.

A liquid crystal display (LCD) displays zone temperature, temperature set points, day of the week, time, and operational mode symbols.

The Option Menu is used to enable or disable applicable functions, i.e.; Morning Warm-up, Economizer minimum position override during unoccupied status, Fahrenheit or Centigrade, Supply air tempering, Remote zone temperature sensor, 12/24 hour time display, Smart fan, and Computed recovery.

During an occupied period, an auxiliary relay rated for 1.25 amps @ 30 volts AC with one set of single pole double throw contacts is activated.

### Status Inputs (4 Wires Optional)

The ZSM can be wired to receive four (4) operating status signals from the RTRM (HEAT, COOL, SYSTEM "ON", SER-VICE).

Four (4) wires from the RTRM should be connected to the appropriate terminals (7, 8, 9 & 10) on the ZSM.

### Remote Zone Sensor (BAYSENS073\*)

This electronic sensor features remote zone sensing and timed override with override cancellation. It is used with a Trane Integrated Comfort™ building management system.

### Remote Zone Sensor (BAYSENS074\*)

This electronic sensor features single setpoint capability and timed override with override cancellation. It is used with a Trane Integrated Comfort™ building management system.

### Remote Zone Sensor (BAYSENS016\*)

This bullet type temperature sensor can be used for; outside air (ambient) sensing, return air temperature sensing, supply air temperature sensing, remote temperature sensing (uncovered). Wiring procedures vary according to the particular application and equipment involved. Refer to the unit's wiring diagrams for proper connections.

### Remote Zone Sensor (BAYSENS077\*)

This electronic sensor can be used with BAYSENS006B, 008B, 010B, 019B Remote Panels. When this sensor is wired to a BAYSENS019B Remote Panel, wiring must be 18 AWG Shielded Twisted Pair (Belden 8760 or equivalent). Refer to The specific Remote Panel for wiring details.

### Electro Mechanical Control

The unit must have a Thermostat to operate.

- BAYSTAT036A
  - Single Stage - 1 Heat/1 Cool
- BAYSTAT037A
  - Multi Stage - 2 Heat/2 Cool - Can be Used for Economizer Operation
- BAYSENS025A
  - Remote sensor for BAYSTAT036A and BAYSTAT037A

### High Temperature Sensor (BAYFRST001A)

This sensor connects to the RTRM Emergency Stop Input on the LTB and provides high limit "shutdown" of the unit. The sensor is used to detect high temperatures due to fire in the air conditioning or ventilation ducts. The sensor is designed to mount directly to the sheet metal duct. Each kit contains two sensors. The return air duct sensor (X1310004001) is set to open at 135 F. The supply air duct sensor (X1310004002) is set to open at 240 F. The control can be reset after the temperature has been lowered approximately 25 F below the cutoff setpoint.

## General Information

---

### Evaporator Frost Control (ReliaTel™ Option)

This input incorporates the Frostat™ control (FOS) mounted in the indoor coil circuit and can be activated by closing a field supplied contact installed in parallel with the FOS.

If this circuit is open before the compressor is started, the compressor will not be allowed to operate. Anytime this circuit is opened for 1 continuous second during compressor operation, the compressor for that circuit is immediately turned "Off". The compressor will not be allowed to restart for a minimum of 3 minutes should the FOS close.

### (Electro Mechanical Option)

This input incorporates the Frostat™ control (FOS) mounted in the indoor coil circuit and can be activated by opening a field supplied contact installed in series with the FOS.

If this circuit is open before the compressor is started, the compressor will not be allowed to operate. Anytime this circuit is opened during compressor operation, the compressor for that circuit is immediately turned "Off". The compressor will restart when the FOS closes.

### Smoke Detector Sensor (Optional)

This sensor is only applicable on units equipped with a RTOM. It provides high limit "shutdown" of the unit and requires a manual reset. The sensor is used to detect smoke due to fire in the air conditioning or ventilation ducts.

**Note:** *The supply and return air smoke detectors are designed to shut off the unit if smoke is sensed in the supply air stream or return air stream. This function is performed by sampling the airflow entering the unit at the return air opening. Follow the instructions provided below to assure that the airflow through the unit is sufficient for adequate sampling. Failure to follow these instructions will prevent the smoke detectors*

*from performing it's design function.*

**Note:** *Airflow through the unit is affected by the amount of dirt and debris accumulated on the indoor coil and filters. To insure that airflow through the unit is adequate for proper sampling by the return air smoke detector, complete adherence to the maintenance procedures, including recommended intervals between filter changes, and coil cleaning is required.*

**Note:** *Periodic checks and maintenance procedures must be performed on the smoke detector to insure that it will function properly. For detailed instructions concerning these checks and procedures, refer to the appropriate section(s) of the smoke detector Installation and Maintenance Instructions provided with the literature package for this unit.*

In order for the supply air smoke detector or return air smoke detector to properly sense smoke in the supply air stream or return air stream, the air velocity entering the smoke detector unit must be between 500 and 4000 feet per minute. Equipment covered in this manual will develop an airflow velocity that falls within these limits over the entire airflow range specified in the evaporator fan performance tables.

There are certain models, however, if operated at low airflow, will not develop an airflow velocity that falls within the required 500 to 4000 feet per minute range. For these models, the design airflow shall be greater than or equal to 1000 feet per minute MINIMUM.

### Phase Monitor

This sensor monitors voltage between the 3 conductors of the 3 phase power supply. Two LED lights are provided. The green light indicates that a balanced 3 phase supply circuit is properly connected. The red light indicates that unit operation has been prevented. There are two conditions that will prevent

unit operation. The power supply circuit is not balanced with the proper phase sequence of L1, L2, L3 for the 3 conductors of a 3 phase circuit. The line to line voltage is not between 180 volts and 633 volts

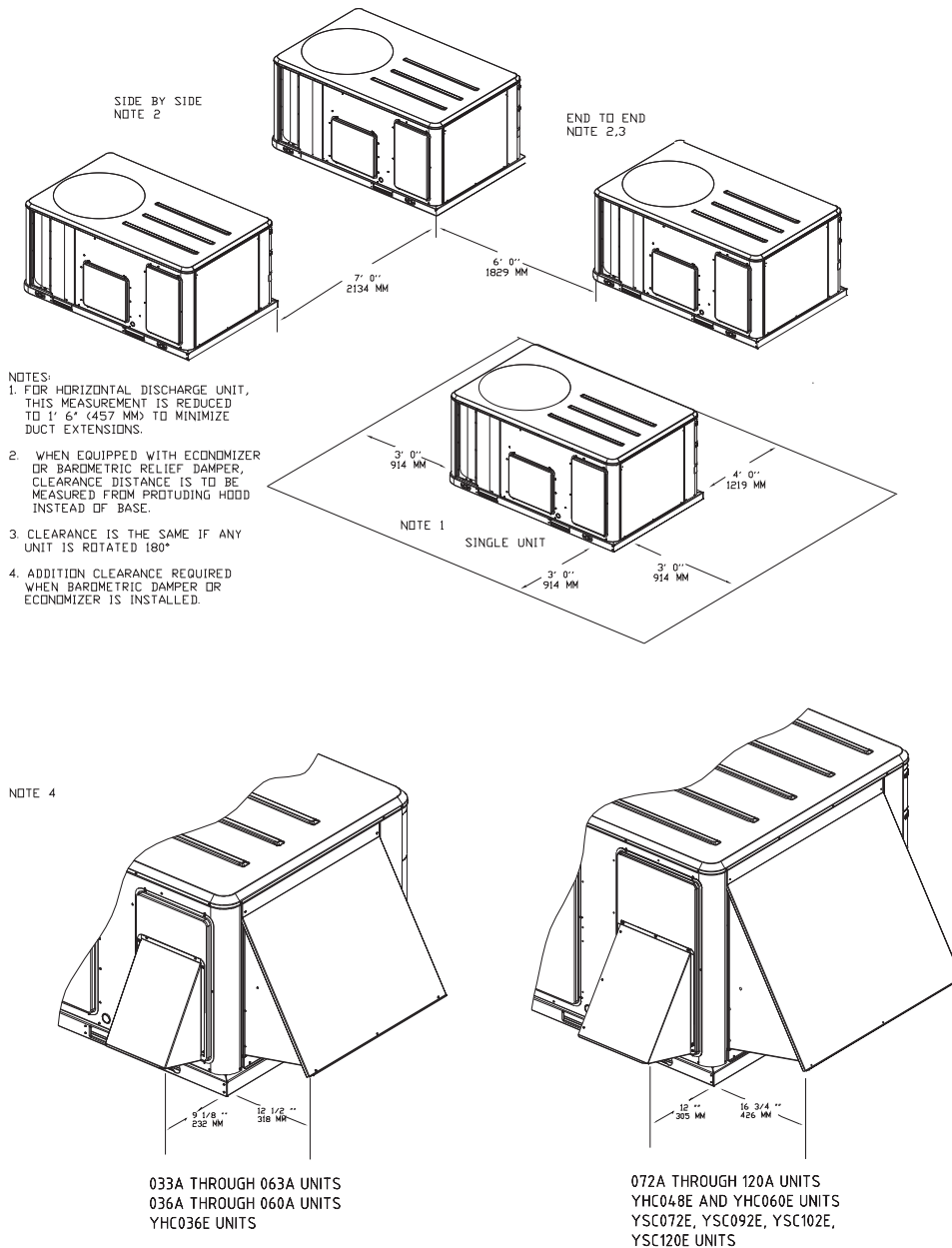
# Unit Dimensions

## Unit Clearances

Figure 1 illustrates the minimum operating and service clearances for either a single or multiple unit installation. These clearances are the minimum distances necessary to assure adequate serviceability, cataloged unit capacity, and peak operating efficiency.

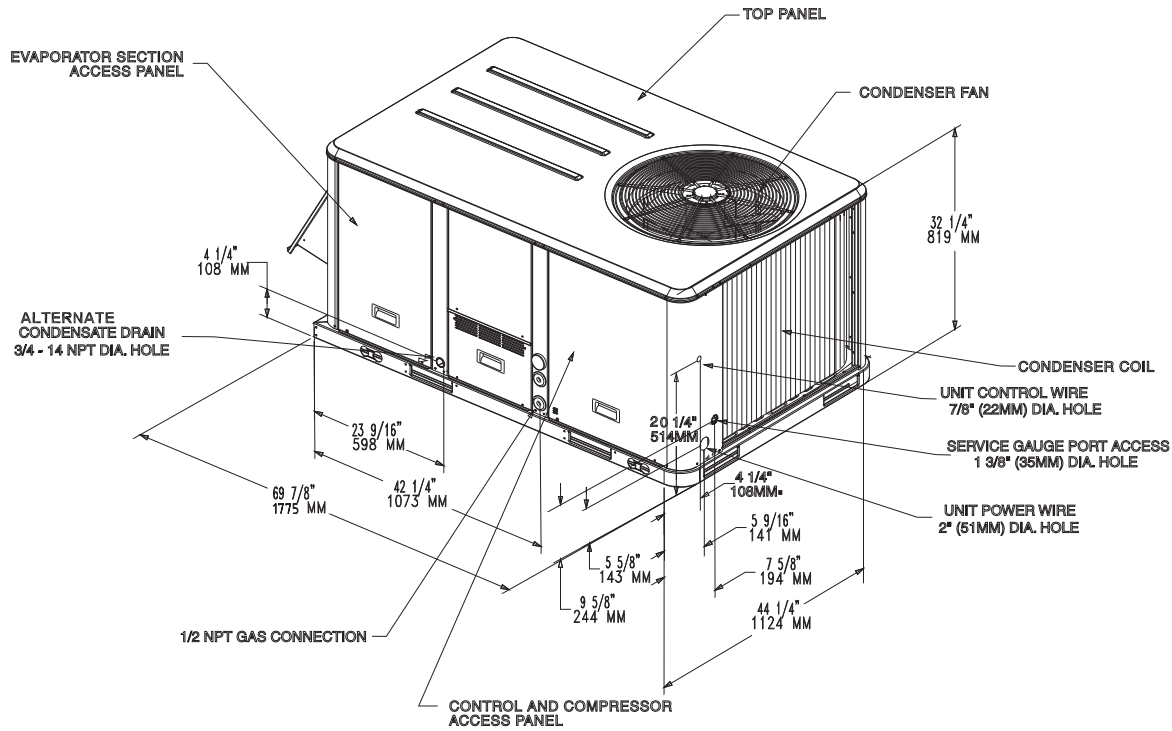
Providing less than the recommended clearances may result in condenser coil starvation, "short-circuiting" of exhaust and economizer airflows, or recirculation of hot condenser air.

Figure 1. Typical Installation Clearances for Single & Multiple Unit Applications

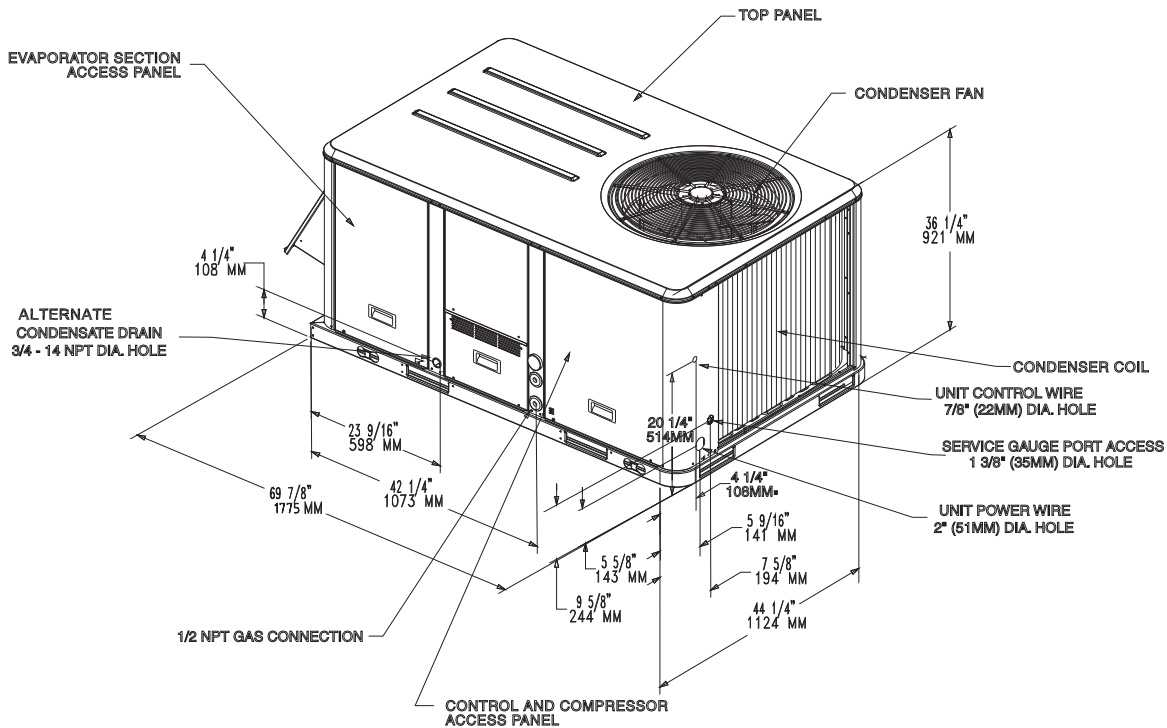


# Unit Dimensions

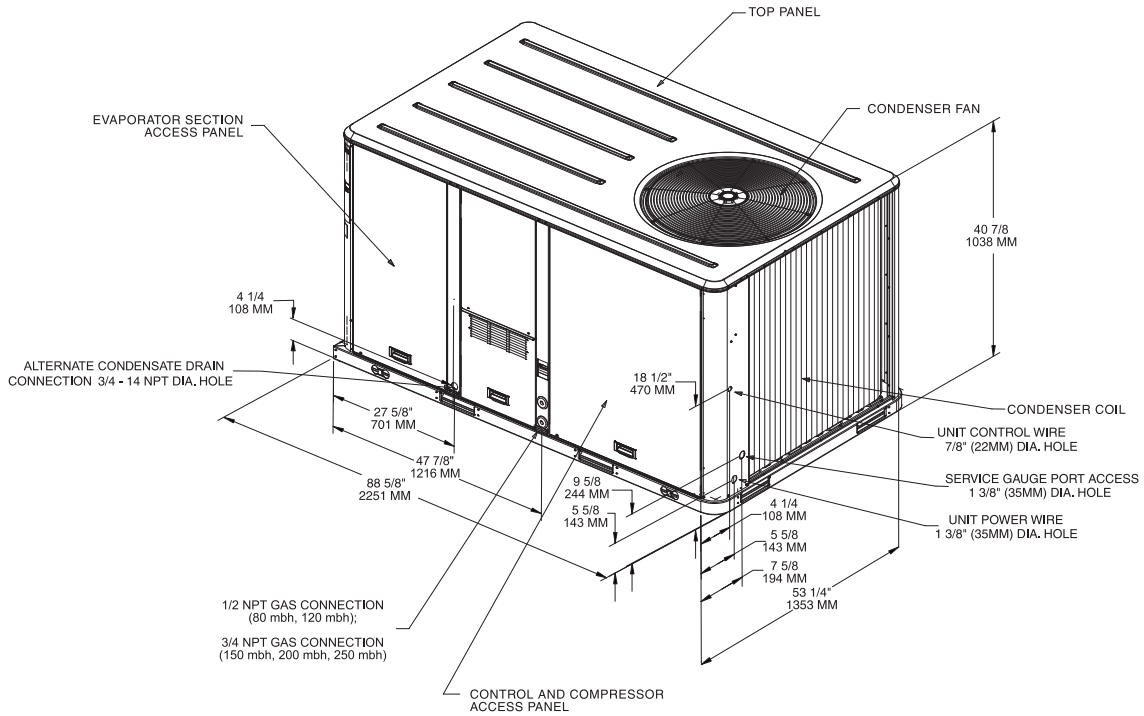
**Figure 2. Unit Dimensional Data YHC033A, Y(H/S)C036A, YHC043A, Y(H/S)C048A – Low and Medium Heat YSC060A – Low and Medium Heat**



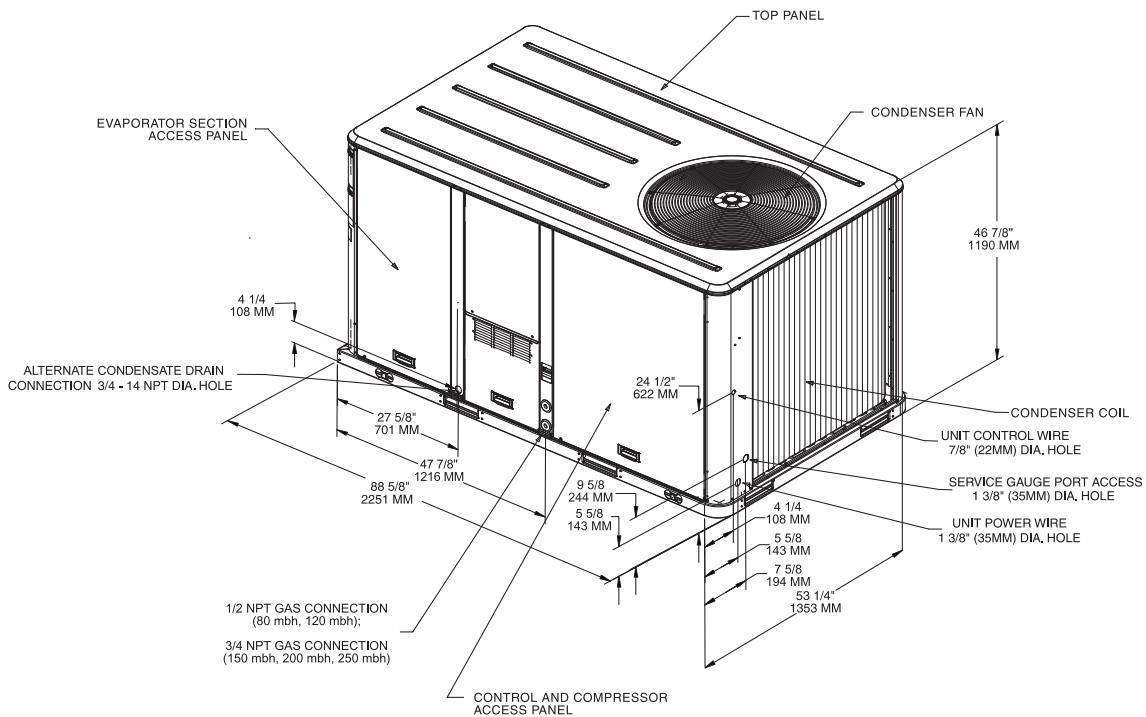
**Figure 3. YHC033A, Y(H/S)C036A, YHC043A, Y(H/S)C048A – High Heat YSC060A – High Heat YHC060A, YHC063A – Low, Medium, and High Heat YSC036E, YSC048E, YSC060E, YHC036E**



**Figure 4. Unit Dimensional Data Y(H/S)C072A, YSC090A, YSC092A, YHC048E, YHC060E, YSC072E**



**Figure 5. Dimensional Data YHC092A, Y(H/S)102A, Y(H/S)C120A, YSC092E, YSC102E, YSC120E**



# Pre-Installation

---

## **WARNING** **Fiberglass Wool!**

Product contains fiberglass wool. Disturbing the insulation in this product during installation, maintenance or repair will expose you to airborne particles of glass wool fibers and ceramic fibers known to the state of California to cause cancer through inhalation. Glass wool fibers may also cause respiratory, skin or eye irritation.

### **Precautionary Measures**

- Avoid breathing fiberglass dust.
- Use a NIOSH approved dust/mist respirator.
- Avoid contact with the skin or eyes. Wear long-sleeved, loose-fitting clothing, gloves, and eye protection.
- Wash clothes separately from other clothing: rinse washer thoroughly.
- Operations such as sawing, blowing, tear-out, and spraying may generate fiber concentrations requiring additional respiratory protection. Use the appropriate NIOSH approved respiration in these situations.

### **First Aid Measures**

**Eye Contact** - Flush eyes with water to remove dust. If symptoms persist, seek medical attention.

**Skin Contact** - Wash affected areas gently with soap and warm water after handling.

# Installation

## **⚠️ WARNING** Heavy Objects!

Do not use cables (chains or slings) except as shown. Each of the cables (chains or slings) used to lift the unit must be capable of supporting the entire weight of the unit. Lifting cables (chains or slings) may not be of the same length. Adjust as necessary for even unit lift. Other lifting arrangements may cause equipment or property-only damage. Failure to properly lift unit could result in death or serious injury.

## **⚠️ WARNING** Improper Unit Lift!

Test lift unit approximately 24 inches to verify proper center of gravity lift point. To avoid dropping of unit, reposition lifting point if unit is not level. Failure to properly lift unit could result in death or serious injury or possible equipment or property-only damage.

Figure 6. Corner weights

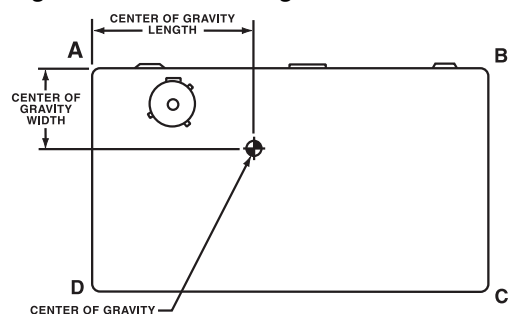


Table 1. Typical unit weights and point loading data

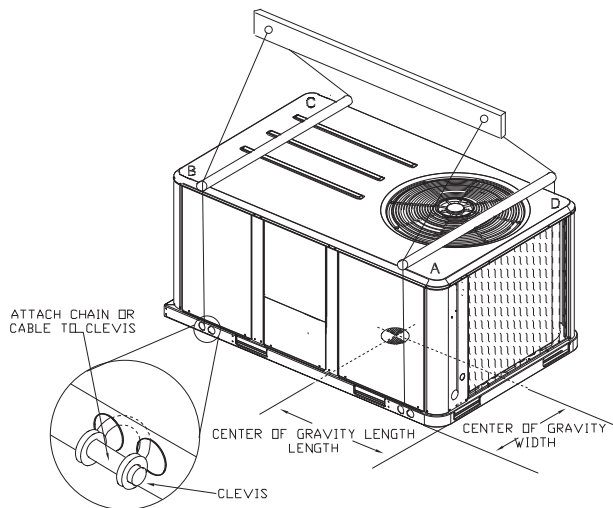
Unit Model	Net Weight (lbs)	Corner Wt. (lbs)				Center of Gravity (In.)	
		A	B	C	D	Length	Width
YSC036A1*(L,M,X,Y)	453	143	116	90	104	32	19
YSC036A1*(H,Z)	480	151	124	96	109	32	19
YSC036A(3,4,W)*(L,M,X,Y)	453	143	116	90	104	32	19
YSC036A(3,4,W)*(H,Z)	480	151	124	96	109	32	19
YSC036E(1,3,4,W)	532	165	137	95	134	31	19
YSC048A1*(L,M,X,Y)	478	151	122	102	103	33	19
YSC048A1*(H,Z)	505	159	130	108	109	33	19
YSC048A(3,4,W)*(L,M,X,Y)	465	146	121	101	97	33	19
YSC048A(3,4,W)*(H,Z)	492	154	129	107	103	33	19
YSC048E(1,3,4,W)	563	175	145	101	142	31	19
YSC060A1*(L,M,X,Y)	494	160	127	99	108	32	18
YSC060A1*(H,Z)	522	169	134	105	114	32	18
YSC060A(3,4,K,W)*(L,M,X,Y)	494	160	127	99	108	32	18
YSC060A(3,4,K,W)*(H,Z)	522	169	134	105	114	32	18
YSC060E(1,3,4,W)	613	190	158	110	155	31	19
YSC072A(3,4,K,W)*(L,X)	720	245	188	129	158	39	21
YSC072A(3,4,W)*(M,Y)	731	248	192	131	160	39	21
YSC072A(3,4,K,W)*(H,Z)	735	249	193	132	161	39	21
YSC072E	793	304	146	219	124	41	23
YSC090A(3,4,K,W)*(L,X)	725	230	203	142	150	42	21
YSC090A(3,4,W)*(M,Y)	729	231	204	143	151	42	21
YSC090A(3,4,K,W)*(H,Z)	741	234	208	146	153	42	21
YSC092A(3,4,W)*(L,X)	806	273	217	143	172	40	21
YSC092A(3,4,W)*(M,Y)	810	274	219	144	173	40	21
YSC092A(3,4,W)*(H,Z)	822	277	222	147	175	40	21
YSC092E	916	370	160	265	121	41	22
YSC102A(3,4,K,W)*(L,X)	883	293	238	161	191	40	21
YSC102A(3,4,W)*(M,Y)	887	294	239	162	192	40	21
YSC102A(3,4,K,W)*(H,Z)	899	297	243	165	194	40	21
YSC102E	953	371	173	277	132	42	23
YSC120A(3,4,K,W)*(L,X)	933	310	253	171	198	40	21
YSC120A(3,4,W)*(M,Y)	945	313	257	174	200	40	21
YSC120A(3,4,K,W)*(H,Z)	958	317	261	177	202	40	21
YSC120E	1030	403	187	283	157	41	23
YHC036A1*(L,M,X,Y)	470	150	120	95	105	32	19
YHC036A1*(H,Z)	497	158	128	101	110	32	19
YHC033A(3,4,W)*(L,M,X,Y)	537	159	139	126	111	32	19
YHC036A(3,4,W)*(L,M,X,Y)	470	150	120	95	105	32	19
YHC033A(3,4,W)*(H,Z)	537	159	139	126	111	32	19
YHC036A(3,4,W)*(H,Z)	497	158	128	101	110	32	19

# Installation

**Table 1. Typical unit weights and point loading data (continued)**

Unit Model	Net Weight (lbs)	Corner Wt. (lbs)				Center of Gravity (In.)	
		A	B	C	D	Length	Width
YHC036E1, E3, E4	544	127	103	204	110	39	26
YHC048A1*(M,Y)	511	157	126	108	121	32	20
YHC048A1*(H,Z)	539	166	133	114	126	32	20
YHC043A(3,4,W)*(L,M,X,Y)	577	167	144	139	127	32	20
YHC048A(3,4,W)*(L,M,X,Y)	511	157	126	108	121	32	20
YHC043A(3,4,W)*(H,Z)	577	167	144	139	127	32	20
YHC048A(3,4,W)*(H,Z)	539	166	133	114	126	32	20
YHC048E1, E3, E4	790	173	145	266	141	40	25
YHC060A1*(L,M)	562	176	137	116	133	31	20
YHC060A1*(H,Z)	574	179	140	119	136	32	20
YHC060A(3,4,W)*(L,M,X,Y)	550	175	133	110	131	31	19
YHC063A(3,4,W)*(L,M,X,Y)	612	180	151	144	137	31	19
YHC060A(3,4,W)*(H,Z)	561	178	137	113	134	31	19
YHC063A(3,4,W)*(H,Z)	561	178	137	113	134	31	19
YHC060E1, E3, E4	748	222	92	345	89	41	24
YHC072A(3,4,W)*(L,X)	756	245	193	137	181	39	22
YHC072A(3,4,W)*(M,Y)	768	248	197	140	183	39	22
YHC072A(3,4,W)*(H,Z)	772	249	198	141	184	39	22
YHC092A(3,4,W)*(L,X)	907	302	238	161	207	39	22
YHC092A(3,4,W)*(M,Y)	911	303	239	162	208	39	22
YHC092A(3,4,W)*(H,Z)	923	306	243	165	210	39	22
YHC102A(3,4,W)*(L,X)	942	306	247	171	217	39	22
YHC102A(3,4,W)*(M,Y)	946	307	248	172	218	39	22
YHC102A(3,4,W)*(H,Z)	957	310	252	175	220	40	22
YHC120A(3,4,W)*(L,X)	1035	336	269	191	240	39	22
YHC120A(3,4,W)*(M,Y)	1047	339	272	194	242	39	22
YHC120A(3,4,W)*(H,Z)	1060	342	277	197	245	40	22

**Figure 7. Rigging and center of gravity**



**Table 2. Typical accessory weights**

Option/Accessory Description	Weight - Net lbs		
	YHC033, 043, 063	YH/ YSC036-060	YH/ YSC072-120
Economizer	26	26	36
Motorized Damper	20	20	30
Manual Damper	16	16	26
Barometric Relief	7	7	10
Power Exhaust	N/A	N/A	80
Oversize Motor	5	5	8
Belt Drive Motor (3 phase only)	Standard	31	Standard
Hinged Access	10	10	12
Hail Guard	12	12	20
Through the Base: Electrical	8	8	13
Through the Base: Gas	5	5	5
Unit Disconnect Switch	5	5	5
Unit Circuit Breaker	5	5	5
Conv. Outlet: Unpowered	2	2	2
Conv. Outlet: Powered	38	38	38
TCI, LCI	1	1	1
NOVAR	8	8	8
HPC	1	1	1
Frostat	1	1	1
Crankcase Heater	1	1	1
Smoke Detector, Return	7	7	7
Smoke Detector, Supply	5	5	5
Clogged Filter Switch	1	1	1
Fan Fail Switch	1	1	1
Discharge Air Tube	3	3	3
Roofcurb	70	70	115
LP Conversion Kit	3	3	3
All Zone Sensors	3	3	1
Hard Start Kit	3	3	N/A
Reheat Coil	15	15	25
Stainless Steel Heat Exchanger	5	5	10

## Foundation

### Horizontal Units

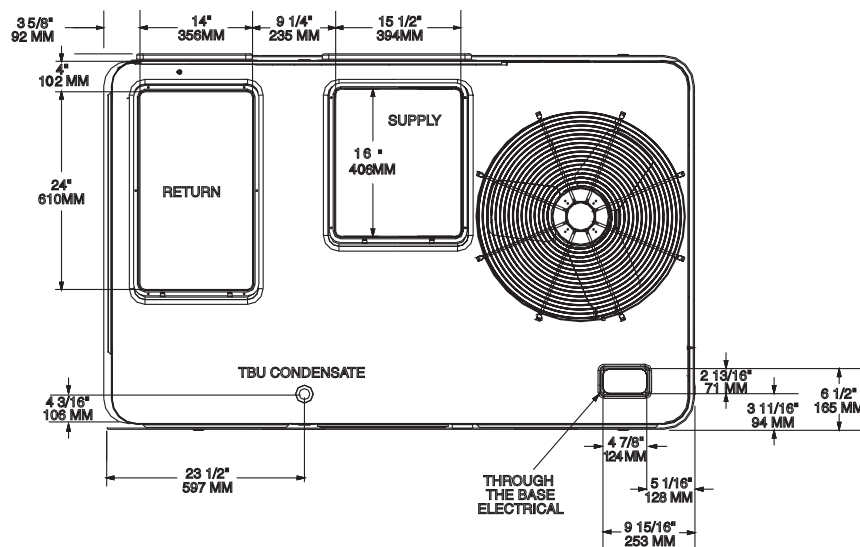
If the unit is installed at ground level, elevate it above the snow line. Provide concrete footings at each support location with a "full perimeter" support structure or a slab foundation for support. Refer to [Table 1, "Typical unit weights and point loading data,"](#) on page 16 for the unit's operating and point loading weights when constructing a footing foundation.

If anchoring is required, anchor the unit to the slab using hold down bolts or isolators. Isolators should be installed to minimize the transmission of vibrations into the building.

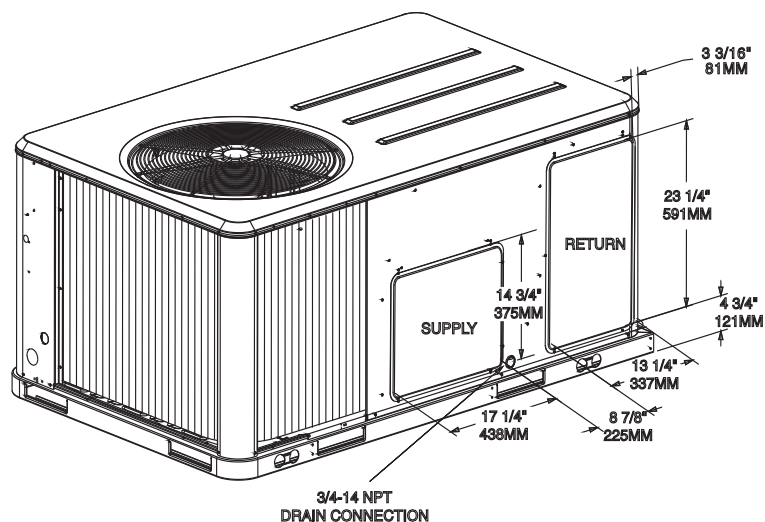
For rooftop applications, ensure the roof is strong enough to support the combined unit and support structural weight. Refer to [Table 1, p. 16](#) for the unit operating weights. If anchoring is required, anchor the unit to the roof with hold-down bolts or isolators.

Check with a roofing contractor for proper waterproofing procedures.

**Figure 9. 3-5 ton R-22, 3-5 ton Standard Efficiency R-410A, 3 ton High Efficiency R-410A Down flow Unit Supply & Return Air Opening**

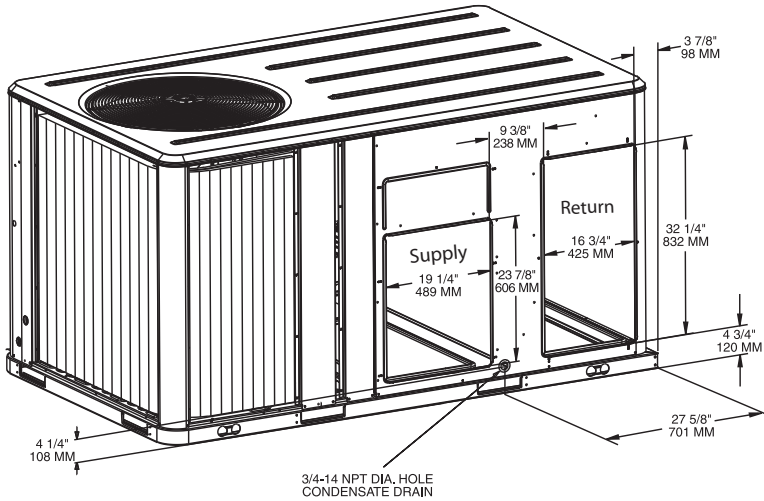


**Figure 8. 3-5 ton R22, 3-5 ton Standard Efficiency R410a, 3 ton High Efficiency R410a Horizontal Unit Supply & Return Air Opening**

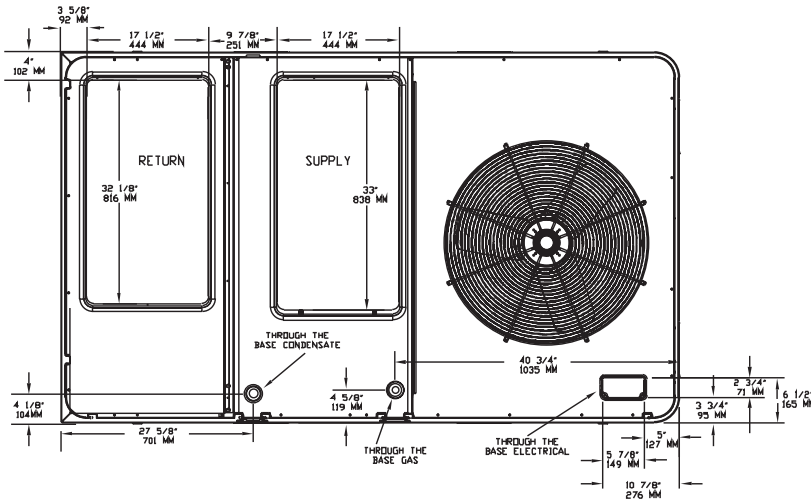


# Installation

**Figure 10. 4-5 ton High Efficiency R410a, 6-10 ton R22 and R410a Horizontal Unit Supply & Return Air Opening**



**Figure 11. 4-5 ton High Efficiency R410a, 6-10 ton R22 and R410a Down flow Unit Supply & Return Air Openings**



## Ductwork

Figure 8, p. 18 illustrates the supply and return air openings as viewed from the rear of the unit.

Elbows with turning vanes or splitters are recommended to minimize air noise due to turbulence and to reduce static pressure.

When attaching the ductwork to the unit, provide a water tight flexible connector at the unit to prevent operating sounds from transmitting through the ductwork.

All outdoor ductwork between the unit and the structure should be weather proofed after installation is completed.

## Roof Curb

### Down flow

The roof curbs for these units consists of a "full perimeter" enclosure to support the unit.

Before installing any roof curb, verify;

- it is the correct curb for the unit,
- it includes the necessary gaskets and hardware,
- the purposed installation location provides the required clearance for proper operation,
- the curb is level and square. The top surface of the curb must be true to assure an adequate curb-to-unit seal.

### **⚠️ WARNING** Combustible Materials!

Maintain proper clearance between the unit heat exchanger, vent surfaces and combustible materials. Refer to unit nameplate and installation instructions for proper clearances. Improper clearances could result in a fire hazard. Failure to maintain proper clearances could result in death or serious injury or property damage.

Verify that appropriate materials were used in the construction of roof and ductwork. Combustible materials should not be used in the construction of ductwork or roof curb that is in close proximity to heater elements or any hot surface. Any combustible material on the inside of the unit base should be removed and replaced with appropriate material.

Step-by-step curb assembly and installation instructions ship with each accessory roof curb kit. Follow the instructions carefully to assure proper fit-up when the unit is set into place.

**Note:** To assure proper condensate flow during operation, the unit (and curb) must be level.

If the unit is elevated, a field constructed catwalk around the unit is strongly recommended to provide easy access for unit maintenance and service.

Recommendations for installing the Supply Air and Return Air ductwork

joining the roof curb are included in the curb instruction booklet. Curb ductwork must be fabricated and installed by the installing contractor before the unit is set into place.

**Note:** For sound consideration, cut only the holes in the roof deck for the ductwork penetrations. Do not cut out the entire roof deck within the curb perimeter.

### If a Curb Accessory Kit is not used:

- The ductwork can be attached directly to the factory-provided flanges around the unit's supply and return air openings. Be sure to use flexible duct connections at the unit.
- For "built-up" curbs supplied by others, gaskets must be installed around the curb perimeter flange and the supply and return air opening flanges.

### Rigging

A Rigging illustration and Center-of-Gravity dimensional data table is shown in [Figure 7, p. 17](#). Refer to the typical unit operating weights table before proceeding.

1. Remove all drill screws fastening wood protection to metal baserail. Remove all screws securing wooden protection to wooden top crate.
2. Remove Wooden Top Crate.

### **⚠** WARNING Heavy Objects!

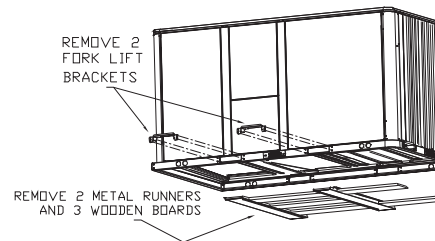
**Do not use cables (chains or slings) except as shown. Each of the cables (chains or slings) used to lift the unit must be capable of supporting the entire weight of the unit. Lifting cables (chains or slings) may not be of the same length. Adjust as necessary for even unit lift. Other lifting arrangements may cause equipment or property-only damage. Failure to properly lift unit could result in death or serious injury. See details below.**

3. Rig the unit as shown in [Figure 7, p. 17](#). Attach adequate strength lifting slings to all four lifting brackets in the unit base rail. Do

not use cables, chains, or slings except as shown.

4. Install a lifting bar, as shown in [Figure 7, p. 17](#), to protect the unit and to facilitate a uniform lift. The minimum distance between the lifting hook and the top of the unit should be 7 feet.
5. Test-lift the unit to ensure it is properly rigged and balanced, make any necessary rigging adjustments.
6. Lift the unit enough to allow the removal of two Fork Lift brackets and hardware. Remove the two Fork Lift brackets, two metal runners and three wooden boards as shown in the following [Figure](#).

**Figure 12. Fork pocket**



7. Down flow units; align the base rail of the unit with the curb rail while lowering the unit onto the curb. Make sure that the gasket on the curb is not damaged while positioning the unit.

### General Unit Requirements

The checklist listed below is a summary of the steps required to successfully install a commercial unit. This checklist is intended to acquaint the installing personnel with what is required in the installation process. It does not replace the detailed instructions called out in the applicable sections of this manual.

- Check the unit for shipping damage and material shortage; file a freight claim and notify appropriate sales representative.
- Verify correct model, options and voltage from unit nameplate.

- Verify that the installation location of the unit will provide the required clearance for proper operation.
- Assemble and install the roof curb (if applicable). Refer to the latest edition of the curb installers guide that ships with each curb kit.
- Fabricate and install ductwork; secure ductwork to curb.
- Install pitch pocket for power supply through building roof. (If applicable)
- Rigging the unit.
- Set the unit onto the curb; check for levelness.
- Ensure unit-to-curb seal is tight and without buckles or cracks.
- Install and connect a condensate drain line to the evaporator drain connection.

### Factory Installed Economizer

- Ensure the economizer has been pulled out into the operating position. Refer to the economizer installers guide for proper position and setup.
- Install all access panels.

### Temperature Limit Switch Usage for Gas Heat Units

Units are factory shipped in the down flow discharge configuration but can be field converted to a horizontal discharge configuration. Some, but not all units require a different TCO1 limit switch, which is attached to the combustion blower motor if horizontal discharge configuration is used.

**Note:** The following units require a limit switch change out for horizontal discharge. The additional limit switch is shipped attached to the combustion blower housing. Proceed to the Horizontal Discharge Conversion, Step 5 on page 24 for the following models "ONLY".  
 Y\*C072A\*\*(H,Z),  
 YSC090A\*\*(H,Z),  
 YSC092A\*\*(H,Z),  
 YHC092A\*\*(M,Y),  
 YHC092A\*\*(H,Z),  
 Y\*C102A\*\*(H,Z),

# Installation

Y\*C120A\*\*(M,Y),  
 Y\*C120A\*\*(H,Z)  
 YSC036E\*\*(M,Y),  
 YSC036E\*\*(H,Z),  
 YSC048E\*\*(H,Z),  
 YHC043A\*\*(H,Z),  
 YSC048A\*\*(H,Z), YHC063A\*\*(M,Y),  
 YSC060A\*\*(H,Z),  
 YHC063A\*\*(H,Z),  
 YSC048E\*\*(M,Y) belt drive ID motor,  
 YSC060E\*\*(H,Z) direct drive ID motor,  
 YHC048E\*\*(L,X) direct drive ID motor,  
 YHC060E\*\*(L,X) belt drive ID,  
 YHC036E\*\*(M,Y),  
 YHC048E\*\*(M,Y),  
 YHC060E\*\*(M,Y) direct drive ID motor,  
 YHC036E\*\*(H,Z),  
 YHC048E\*\*(H,Z) belt drive ID motor,  
 YHC060E\*\*(H,Z),  
 YSC072E\*\*(H,Z), YSC092E\*\*(M,Y),  
 YSC092E\*\*(H,Z),  
 YSC102E\*\*(H,Z),  
 YSC120E\*\*(M,Y),  
 YSC120E\*\*(H,Z).

If any of the aforementioned units are installed in the down flow discharge configuration, remove the additional TCO1 limit switch from the combustion blower motor and discard.

BD= Belt drive ID motor

DD= Direct drive ID motor

**Table 3. TCO1 tripping values**

Unit Model	TCO1 Tripping Values Down flow/ Horizontal
YHC033A**(L,X)	170F
YHC033A**(M,Y)	220F
YHC033A**(H,Z)	210F
YSC036E**(L,X)-DD	180F
YSC036E**(L,X)-BD	170F
Y*C036A**(L,X)	170F
YSC036E**(M,Y)-DD	170F/190F
YSC036E**(M,Y)-BD	180F/190F
Y*C036A**(M,Y)	220F
YSC036E**(H,Z)-DD	170F/190F
YSC036E**(H,Z)-BD	155F/190F
Y*C036A**(H,Z)	210F
YHC043A**(L,X)	170F
YHC043A**(M,Y)	170F
YHC043A**(H,Z)	180F / 220F
YSC048E**(L,X)-DD	180F
YSC048E**(L,X)-BD	170F
Y*C048A**(L,X)	170F

**Table 3. TCO1 tripping values**

Unit Model	TCO1 Tripping Values Down flow/ Horizontal
Y*C048A**(M,Y)	170F
YSC048E**(H,Z)-DD	155F/210F
YSC048E**(M,Y)-BD	170F/190F
YSC048E**(M,Y)-DD	180F
YSC048E**(H,Z)-BD	155F/200F
Y*C048A**(H,Z)	180F / 220F
YSC060E**(L, X)	170
YHC060A**(L,X)	155F
YSC060E**(M,Y)	170F
YHC060A**(M,Y)	155F / 170F
YSC060E**(H,Z)-DD	170F/200F
YSC060E**(H,Z)-BD	170F
YHC063A**(L,X)	155F
YHC063A**(M,Y)	155F / 170F
YHC063A**(H,Z)	170F / 200F
YSC060A**(L,X)	170F
YSC060A**(M,Y)	170F
Y*C060A**(H,Z)	170F / 200F
Y*C072A**(L,X)	170F
Y*C072A**(M,Y)	155F
Y*C072A**(H,Z)	145F/155F
YSC072E**(M,Y)	155F
YSC072E**(L,X)	170F
YSC072E**(H,Z)	145F/155F
YSC090A**(L,X)	155F
YSC090A**(M,Y)	170F
YSC090A**(H,Z)	180F/220F
YHC092A**(L,X)	225F
YHC092A**(M,Y)	180F/220F
YHC092A**(H,Z)	200F / 260F
YSC092A**(L,X)	155F
YSC092A**(M,Y)	170F
YSC092A**(H,Z)	180F/220F
YSC092E**(L,X)	225F
YSC092E**(M,Y)	180F / 220F
YSC092E**(H,Z)	220F / 260F
Y*C102A**(L,X)	225F
Y*C102A**(M,Y)	230F
Y*C102A**(H,Z)	200F / 260F
Y*C102E**(L,X)	225F
YSC102E**(M,Y)	230F
YSC102E**(H,Z)	200F / 260F
Y*C120A**(L,X)	230F
Y*C120A**(M,Y)	190F / 260F
Y*C120A**(H,Z)	230F / 210F
YSC120E**(L,X)	230F

**Table 3. TCO1 tripping values**

Unit Model	TCO1 Tripping Values Down flow/ Horizontal
YSC120E**(M,Y)	190F / 260F
YSC120E**(H,Z)	230F / 210F
YHC036E**(L,X)-DD	180F
YHC036E**(L,X)-BD	170F
YHC036E**(M,Y)-DD	170F/190F
YHC036E**(M,Y)-BD	180F/190F
YHC036E**(H,Z)-DD	170F/190F
YHC036E**(H,Z)-BD	155F/190F
YHC048E**(L,X)-DD	145F/155F
YHC048E**(L,X)-BD	155F
YHC048E**(M,Y)-DD	150F/170F
YHC048E**(M,Y)-BD	170F/180F
YHC048E**(H,Z)-DD	220F
YHC048E**(H,Z)-BD	220F/260F
YHC060E**(L,X)-DD	140F
YHC060E**(L,X)-BD	155F/145F
YHC060E**(M,Y)-DD	145F/170F
YHC060E**(M,Y)-BD	170F
YHC060E**(H,Z)-DD	190F/220F
YHC060E**(H,Z)-BD	220F/230F

## Horizontal Discharge Conversion

### 3 Through 5 Ton Units

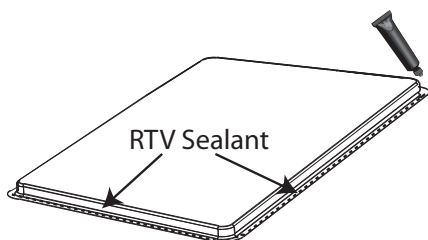
Supplies Needed by Installer for Conversion: 3 oz. tube of High Temperature RTV sealant. (500°F / 260°C: Similar to Dow Corning 736)

**Note:** Failure to use recommended sealant could result in unit performance loss.

If a unit is to be converted to a Horizontal discharge, the following conversion must be performed:

1. Remove RETURN and SUPPLY duct covers.
2. Locate supply cover. Apply ¼ in. (6mm.) continuous bead of 500°F RTV sealant to the flange as shown.

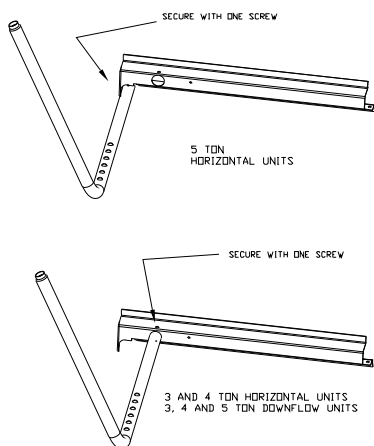
**Figure 13.**



- Position duct cover as shown, rotate 90 degrees to allow entrance into supply opening.

**Note:** If unit is equipped with Discharge Air Sensing option refer to the following figure for proper tube positioning based on unit tonnage.

**Figure 14.**



- Slide duct covers into duct openings until inward edge of duct cover engages with the 2 retaining clips on the duct flanges. Secure the outward edge of each duct cover with 2 screws.
- Slide RETURN DUCT COVER (insulation side up) into supply opening until inward edge of duct cover engages with the 2 retaining clips on the duct flange. Secure outward edge of the duct cover with two screws.

**Note:** Certain unit/electric heater combinations require a limit switch change out for horizontal airflow applications. Refer to the following instructions to determine if this process is

required for the unit undergoing installation.

- After completing installation of the duct covers for horizontal discharge, proceed to TCO-1 instructions.

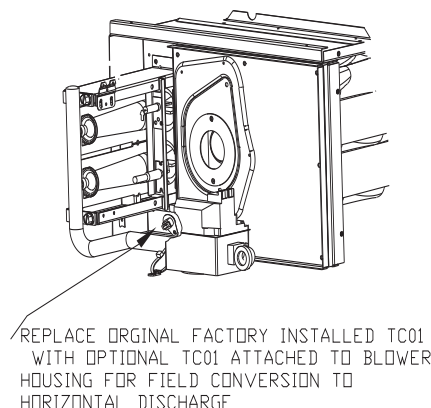
## TCO-1 Instructions:

If the unit being installed is listed in the following table the limit control TCO1 must be replaced with the extra limit control shipped in the heater compartment. Replace TCO1 following the instructions in steps 1 through 3 below. If the unit being installed does not correspond to any in the following table, skip steps 1 through 3 and go on to next step in the installation process.

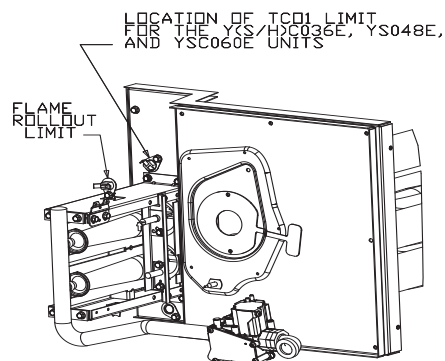
### Unit Model Number

YSC036E\*\*(M,Y), YSC036E\*\*(H,Z), YSC048E\*\*(H,Z), YHC043A\*\*(H,Z), YSC048A\*\*(H,Z), YHC063A\*\*(M,Y), YSC060A\*\*(H,Z), YHC063A\*\*(H,Z), YSC048E\*\*(M,Y) belt drive ID motor, YSC060E\*\*(H,Z) direct drive ID motor, YHC048E\*\*(L,X) direct drive ID motor, YHC060E\*\*(L,X) belt drive ID motor, YHC036E\*\*(M,Y), YHC048E\*\*(M,Y), YHC060E\*\*(M,Y) direct drive ID motor, YHC036E\*\*(H,Z), YHC048E\*\*(H,Z) belt drive ID motor, YHC060E\*\*(H,Z).

**Figure 15.**



**Figure 16.**



## ⚠ WARNING Hazardous Voltage!

Disconnect all electric power, including remote disconnects before servicing. Follow proper lockout/tagout procedures to ensure the power can not be inadvertently energized. Failure to disconnect power before servicing could result in death or serious injury.

- Remove the heat section access panel.
- Remove TCO1 from shipping location, attached to the combustion blower.
- Replace and discard the existing TCO1 originally installed at the factory for down flow operation with the TCO1 shipped attached to the combustion blower for horizontal operation.
- Replace heat section access panel.

## Horizontal Discharge Conversion

### 6 Through 10 Ton Units

Supplies Needed by Installer for Conversion: 3 oz. tube of high Temperature RTV sealant. (500°F / 260°C: Similar to Dow Corning 736)

**Note:** Failure to use recommended sealant could result in unit performance loss.

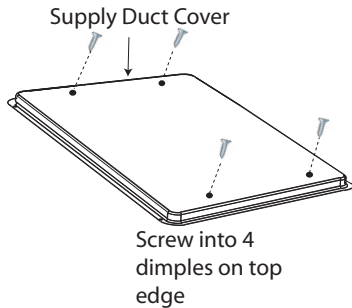
If a unit is to be converted to a Horizontal discharge, the following conversion must be performed:

- Remove RETURN and SUPPLY duct covers.

# Installation

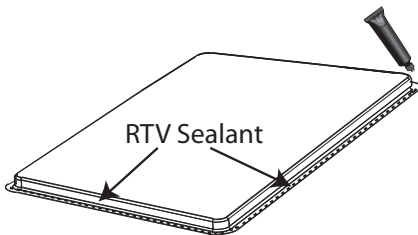
- Place SUPPLY DUCT COVER over down-flow return opening. (insulation side down)
- Using self-drilling screws, (or screws removed from duct cover), screw through dimples to attach DUCT COVER to base.

Figure 17.



- On original RETURN DUCT COVER, apply 1/4" (6mm.) continuous bead of 500°F RTV sealant around flange (opposite insulation side), as shown.

Figure 18.



- Slide RETURN DUCT COVER (insulation side up) into supply opening until inward edge of duct cover engages with the 2 retaining clips on the duct flange. Secure outward edge of the duct cover with two screws.

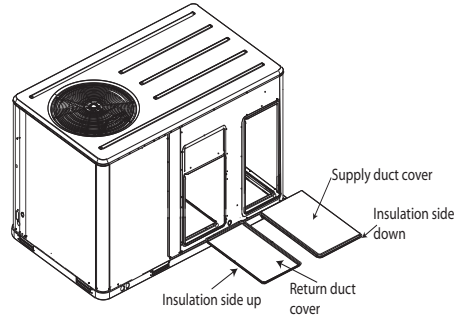
**Note:** If Unit is equipped with Return Air Smoke Detector, refer to field conversion instructions for horizontal discharge before installing return air duct.

**Note:** Note: Certain unit/electric heater combinations require a limit switch change out for horizontal airflow applications. Refer to the following instructions to determine if this process is

*required for the unit undergoing installation.*

- After completing installation of the duct covers for horizontal discharge, proceed to TCO-1 instructions.

Figure 19. Duct cover



## TCO1 Instructions:

If the unit being installed is listed in the following table the limit control TCO1 must be replaced with the extra limit control shipped in the heater compartment. Replace TCO1 following the instructions in steps 1 through 3 below. If the unit being installed does not correspond to any in the following table, skip steps 1 through 3 and go on to next step in the installation process.

Unit Model Number

Y\*C072A\*\*(H,Z), YHC092A\*\*(M,Y),  
YHC092A\*\*(H,Z), YSC090A\*\*(H,Z),  
YSC092A\*\*(H,Z), Y\*C102A\*\*(H,Z),  
Y\*C120A\*\*(M,Y), Y\*C120A\*\*(H,Z),  
YSC072E\*\*(H,Z), YSC092E\*\*(M,Y),  
YSC092E\*\*(H,Z), YSC102E\*\*(M,Y),  
YSC102E\*\*(H,Z), YSC120E\*\*(M,Y),  
YSC120E\*\*(H,Z)

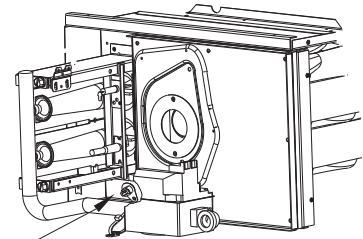
## **⚠ WARNING** Hazardous Voltage!

**Disconnect all electric power, including remote disconnects before servicing. Follow proper lockout/tagout procedures to ensure the power can not be inadvertently energized. Failure to disconnect power before servicing could result in death or serious injury.**

- Remove the heat section access panel.
- Remove TCO1 from shipping location, attached to the combustion blower.

- Replace and discard the existing TCO1 originally installed at the factory for down flow operation with the TCO1 shipped attached to the combustion blower for horizontal operation.
- Replace heat section access panel.

Figure 20.



REPLACE ORIGINAL FACTORY INSTALLED TCO1 WITH OPTIONAL TCO1 ATTACHED TO BLOWER HOUSING FOR FIELD CONVERSION TO HORIZONTAL DISCHARGE

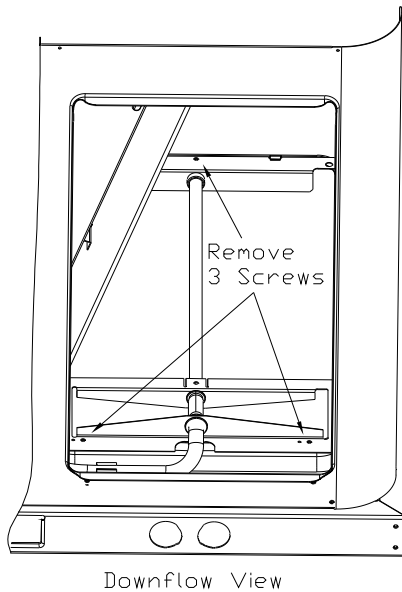
## Return Air Smoke Detector

The factory installed Return Air Smoke Detector is installed in the Down flow discharge position. No additional field setup is required.

If a unit is to be converted to Horizontal discharge, the following conversion must be performed:

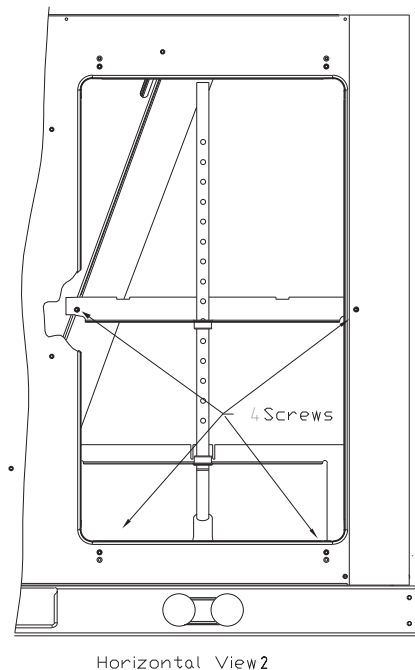
- If the unit has an economizer, it must be pulled out in the operating position.
- Remove the 3 screws from the mounting brackets. Refer to Down flow View for screw locations.

**Figure 21. Down flow view**



- Lift the tube and bracket from the down flow duct opening. Rotate the tube and bracket assembly 180 degrees ensuring that the holes on the copper sensing tube face away from the unit and face the return air ductwork. Refer to Horizontal View.

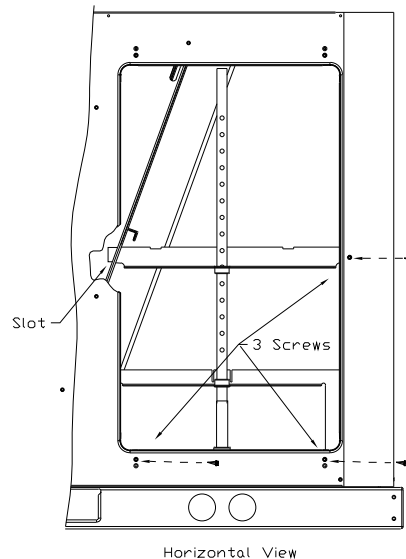
**Figure 22. Horizontal view 2**



**Note:** Check to insure that the flexible tubing lies flat on the base pan surface.

- Slide the top bracket down the copper sensing tube. For YSC036A-060A, YHC033A-060A, YSC036E-060E, and YHC036E units insert the tab on the left side into the slot on the indoor coil block off and secure the right side of the bracket with one of the 3 screws removed in step 2. Refer to Horizontal View 1. For YSC072A-120A, YHC072A-120A, YHC048E-060E and YSC072E-120E units secure the tab on left side to the indoor coil block off with one of the screws removed in step 2 and secure the right side of the bracket with one of the screws removed from the access panel. Refer to Horizontal View 2.

**Figure 23. Horizontal view**



- Using the remaining 2 screws removed in step 2, secure the bottom bracket. Refer to Horizontal View.

**Note:** Larger diameter holes on bottom bracket line up with the dimples on the rear panel. The smaller diameter holes line up with the screw holes in the rear panel.

## Main Electrical Power Requirements

### **⚠ WARNING** Hazardous Voltage w/ Capacitors!

Disconnect all electric power, including remote disconnects and discharge all motor start/run capacitors before servicing. Follow proper lockout/tagout procedures to ensure the power cannot be inadvertently energized. Verify with an appropriate voltmeter that all capacitors have discharged. Failure to disconnect power and discharge capacitors before servicing could result in death or serious injury.

Verify that the power supply complies with the unit nameplate specifications.

- Inspect all control panel components; tighten any loose connections.
- Connect properly sized and protected power supply wiring to a field-supplied/installed disconnect switch and to the main power terminal block (HTB1) in the unit control panel.
- Install proper grounding wires to an earth ground.

**Note:** All field-installed wiring must comply with NEC and applicable local codes.

## Through the Base Gas Installation

The gas supply line must extend 4-5/8" above the basepan. The "Through the Base Gas kit" is located in the Heat Vestibule compartment. To gain access to the kit, remove the Heat Compartment access panel.

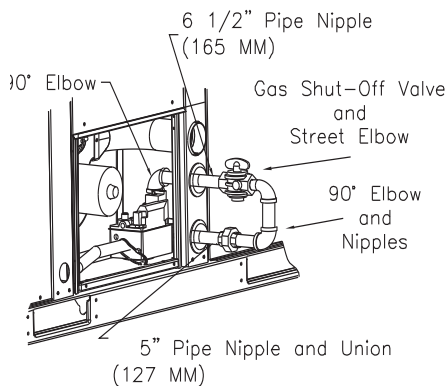
Remove the pipe assembly strapped to the manifold. Unscrew 90° elbow from 6 1/2" nipple and slide rubber grommet off of nipple.

- Remove the plastic plug from the hole in the center post and insert the grommet removed from 6-1/2" pipe nipple.
- Using pipe sealant, attach the 90° elbow to the gas supply line.
- Disconnect the 5" pipe nipple and union from the "Through the Base Gas kit assembly".

## Installation

4. Using pipe sealant, attach the 6 1/2" nipple and gas shutoff assembly to the 90° elbow on the gas supply line.
5. Using pipe sealant, attach the 5" pipe nipple and union to the street elbow attached to the gas valve.
6. Connect 5" pipe nipple and union to 6 1/2" nipple and gas shutoff assembly.

**Figure 24. Typical through the base gas installation**



## Requirements for Gas Heat

**Note:** *The unit gas train and Optional Through The Base Gas Shut-Off Valve are rated at 1/2 PSIG maximum. A pressure reducing regulator is recommended to prevent this maximum from being exceeded. These components must be isolated during field gas piping test that exceed 1/2 PSIG. It is recommended that the field piping be capped prior to the unit gas train or Optional Through The Base Gas Shut-Off Valve if present.*

- Gas supply line properly sized and connected to the unit gas train.
- All gas piping joints properly sealed.
- Gas piping leak checked with a soap solution. If piping connections to the unit are complete, do not pressurize

piping in excess of 0.50 psig or 14" W.C. to prevent component failure.

- Drip leg Installed in the gas piping near the unit.
- Minimum gas supply pressure should be 4.5" W.C.
- Maximum gas supply pressure must not exceed 14.0" W.C.
- Manifold pressure for single stage heaters should be set to 3.3" W.C.
- Manifold pressure for two stage heaters should be set to 3.5" W.C. on HIGH FIRE and 1.8" W.C. on LOW FIRE.
- Flue Exhaust clear of any obstruction.

## Condensate Drain Configuration

An evaporator condensate drain connection is provided on each unit. Refer to [Figure 8, p. 18](#) and [Figure 10, p. 19](#) for the appropriate drain location.

The condensate drain pan is factory installed to drain condensate to the back side of the unit. See [Figure 8, p. 18](#) and [Figure 10, p. 19](#). It can be converted to drain condensate out the front side of the unit or through the base.

To convert drain condensate out the front of unit:

1. Remove evaporator access panel and supply air access panels.
2. Remove the support panel that the condensate drain pan exits through.
3. Slide the condensate drain pan out of the unit and rotate 180°.
4. Slide the condensate drain pan back into the unit, align the drain with the grommetted opening in the rear support panel and push until the coupling is seated in the grommet.
5. Replace the front support panel by aligning the panel with tabs in the raceway. Align the condensate drain pan support in the grommetted hole as the panel is put in place.

6. Replace evaporator access panel and supply air access panels.

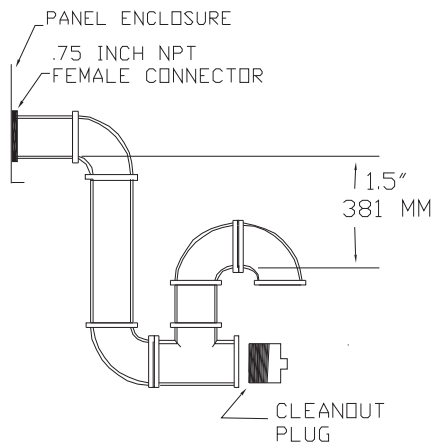
## To convert drain condensate through the base of unit:

1. Remove evaporator access panel and supply air access panels.
2. Remove the support panel that the condensate drain pan exits through.
3. Slide the condensate drain pan out of the unit.
4. Place on a level surface in the position it was removed from the unit.
5. Remove the plug knockout in the bottom of the drainpan to convert it to through the base drainage.
6. Plug the original condensate drain opening with a field supplied 3/4" NPT plug.
7. Slide the condensate drain pan back into the unit, align the drain support with the grommetted opening in the rear support panel and push until the support is seated in the grommet.
8. Replace the front support panel by aligning the panel with tabs in the raceway. Align the plugged condensate drain pan coupling in the grommetted hole as the panel is put in place.
9. Replace evaporator access panel and supply air access panels.

A condensate trap must be installed at the unit due to the drain connection being on the "negative pressure" side of the fan. Install the P-Trap using the guidelines in [Figure 25, p. 26](#).

A condensate drain line must be connected to the P-Trap. Pitch the drain lines at least 1/2 inch for every 10 feet of horizontal run to assure proper condensate flow. Do not allow the horizontal run to sag causing a possible double-trap condition which could result in condensate backup due to "air lock".

**Figure 25. Condensate trap installation**



## Filter Installation

Each unit ships with one inch filters. The quantity of filters is determined by unit size. Access to the filters is obtained by removing the indoor fan access panel. To modify the unit's filter rack to accept two inch filters, remove the L-shaped angle attachment screws and rotate the angles 90 degrees.

Reinstall the screws and insert new filters. Refer to the unit Service Facts (shipped with each unit) for filter requirements.

**Note:** Do not operate the unit without filters.

## Field Installed Power Wiring

An overall dimensional layout for the field installed wiring entrance into the unit is illustrated in "Unit Dimensions," p. 12. To insure that the unit's supply power wiring is properly sized and installed, follow the following guidelines.

### **⚠ WARNING** Ground Wire!

All field-installed wiring must be completed by qualified personnel. All field-installed wiring must comply with NEC and applicable local codes, failure codes. Failure to follow this instruction could result in death or serious injuries.

Verify that the power supply available is compatible with the unit's nameplate ratings. The available supply power must be within 10% of the rated voltage stamped on the nameplate. Use only copper conductors to connect the power supply to the unit.

### **CAUTION** Equipment Damage!

Use copper conductors only. Unit terminals are not designed to accept other types of conductors. Failure to use copper conductors may result in equipment damage.

**Note:** If the unit is not equipped with an optional factory installed non-fused disconnect switch or circuit breaker, a field supplied disconnect switch must be installed at or near the unit in accordance with the National Electrical Code (NEC latest edition).

## Main Unit Power

### Standard Wiring

1. Location of the applicable electrical service entrance is illustrated in "Unit Dimensions," p. 12. Complete the unit's power wiring connections at Compressor Contactor # 1 (CC1) inside the unit control panel. Refer to the customer connection diagram that is shipped with the unit for specific termination points
2. Provide proper grounding for the unit in accordance with local and national codes.

## Main Unit Power

### Optional TBUE Wiring (Through the Base Electrical Option)

1. Location of the applicable electrical service is illustrated below. Refer to the customer connection diagram that is shipped with the unit for specific termination points. The termination points, depending on the customer option selected would be a factory mounted nonfused disconnect switch

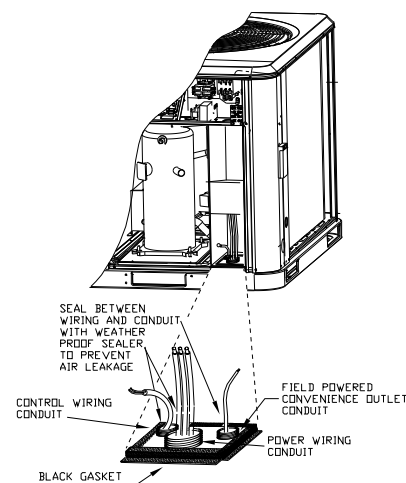
(UDC) or circuit breaker (UCB). If neither a factory mounted nonfused disconnect switch (UDC) or circuit breaker (UCB) was factory mounted, field wiring connections should be terminated in the control box at Compressor Contactor # 1 (CC1).

2. Provide proper grounding for the unit in accordance with local and national codes.

**Note:** Black Gasket is shipped from the factory and is located in the literature Ship With bag in the control box. Apply Black Gasket around conduit plate on all 4 sides after installation to prevent air leakage from the building entering the electrical enclosures.

**Note:** Seal between wiring and conduit with Black Gasket or weather proof sealer to prevent air leakage from the building entering the electrical enclosures. Also seal around conduit and wiring at all roof and curb penetrations.

**Figure 26.**



## Field Installed Control Wiring

An overall layout of the various control options available with the required number of conductors for each control device is illustrated in Figure 24, p. 25.

# Installation

**Note:** All field wiring must conform to NEC guidelines as well as state and local codes.

## Control Power Transformer

The 24 volt control power transformers are to be used only with the accessories called out in this manual. Transformers rated greater than 50 VA are equipped with internal circuit breakers. If a circuit breaker trips, turn "Off" all power to the unit before attempting to reset it.

### **⚠️ WARNING** Hazardous Voltage!

**Disconnect all electric power, including remote disconnects before servicing. Follow proper lockout/tagout procedures to ensure the power can not be inadvertently energized. Failure to disconnect power before servicing could result in death or serious injury.**

Failure to disconnect power before servicing can cause severe personal injury or death.

The transformer is located in the control panel. The circuit breaker is located on the left side of the transformer and can be reset by pressing in on the black reset button.

## Controls using 24 VAC

Before installing any connecting wiring, refer to "Unit Dimensions," p. 12 for the electrical access locations provided on the unit and Table 4 or Table 5 for AC conductor sizing guidelines, and;

1. Use copper conductors unless otherwise specified.
2. Ensure that the AC control wiring between the controls and the unit's termination point does not exceed three (3) ohms/conductor for the length of the run.

**Note:** Resistance in excess of 3 ohms per conductor may cause component failure due to insufficient AC voltage supply.

**Note:** Be sure to check all loads and conductors for grounds, shorts, and mis-wiring.

3. Do not run the AC low voltage wiring in the same conduit with the high voltage power wiring.

4. Route low voltage wiring per illustrations on page 24.

**Table 4. Electromechanical Thermostat 24V AC Conductors with ReliaTel**

Distance from Unit to Control	Recommended Wire Size
000 - 460 feet	18 gauge
000 - 140 m	.75 mm2
461 - 732 feet	16 gauge
141 - 223 m	1.3 mm2
733 - 1000 feet	14 gauge
224 - 305 m	2.0 mm2

**Table 5. Electromechanical Thermostat 24V AC Conductors with Electromechanical Unit**

Distance from Unit to Control	Recommended Wire Size
0 - 30 feet	22 gauge
0 - 9.1 m	.33 m2
31 - 50 feet	20 gauge
9.5 - 15.2 m	.50m2
51 - 75 feet	18 gauge
15.5 - 22.9 m	.75 m2
76 - 125 feet	16 gauge
23.1 - 38.1 m	1.3 m2
126 - 200 feet	14 gauge
38.4 - 60.9 m	2.0 m2

## Controls using DC Analog Input/Outputs

### (Standard Low Voltage Multi conductor Wire)

Before installing any connecting wiring between the unit and components utilizing a DC analog input/output signal, refer to "Unit Dimensions," p. 12 for the electrical access locations provided on the unit.

- Table 6 lists the conductor sizing guidelines that must be followed when interconnecting the DC binary output devices and the system components utilizing a DC analog input/output signal to the unit.

**Note:** Resistance in excess of 2.5 ohms per conductor can cause deviations in the accuracy of the controls.

**Note:** Ensure that the wiring between controls and the unit's termination point does not exceed two and a half (2.5) ohms/conductor for the length of the run.

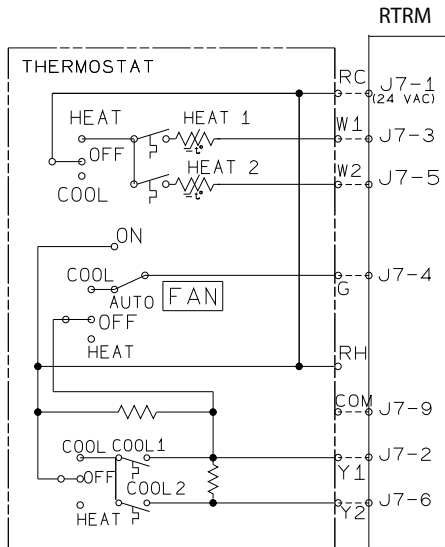
- Do not run the electrical wires transporting DC signals in or around conduit housing high voltage wires.
- Route low voltage wiring per illustrations on page 24.

## DC Conductors

**Table 6. Zone Sensor Module wiring**

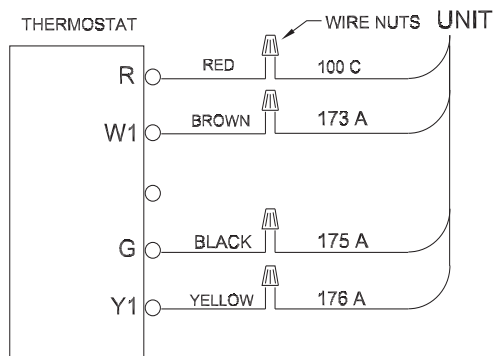
Distance from Unit to Control	Recommended Wire Size
0 - 150 feet	22 gauge
0 - 45.7 m	.33 mm2
151 - 240 feet	20 gauge
46 - 73.1 m	.50 mm2
241 -385 feet	18 gauge
73.5 - 117.3 m	.75 mm2
386 - 610 feet	16 gauge
117.7 - 185.9 m	1.3 mm2
611 - 970 feet	14 gauge
186.2 - 295.7 m	2.0 mm2

**Figure 27. ReliaTel conventional thermostat field wiring diagrams**

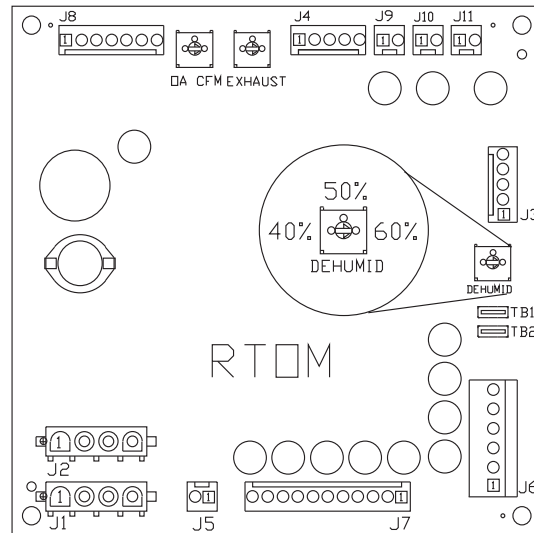


**Figure 28. Typical field wiring diagrams for Electro Mechanical**

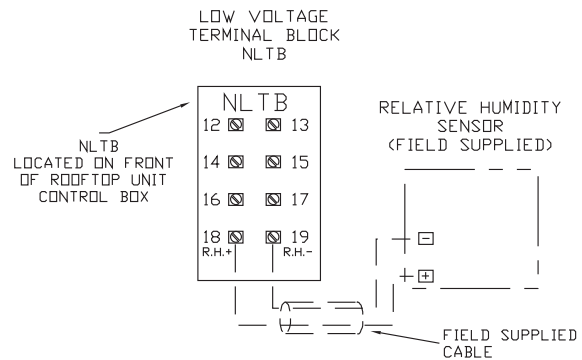
**ELECTRO MECHANICAL THERMOSTAT  
GAS / ELECTRIC UNITS**



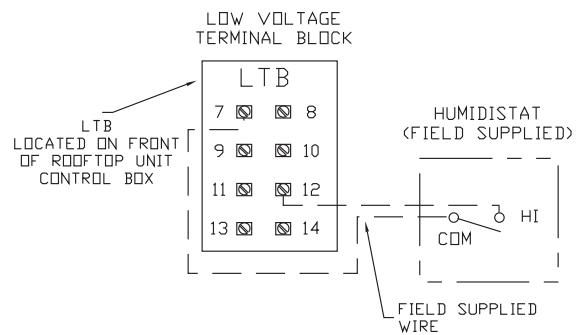
**Figure 29. ReliaTel options module**



**Figure 30. ReliaTel relative humidity sensor (dehumidification option)**

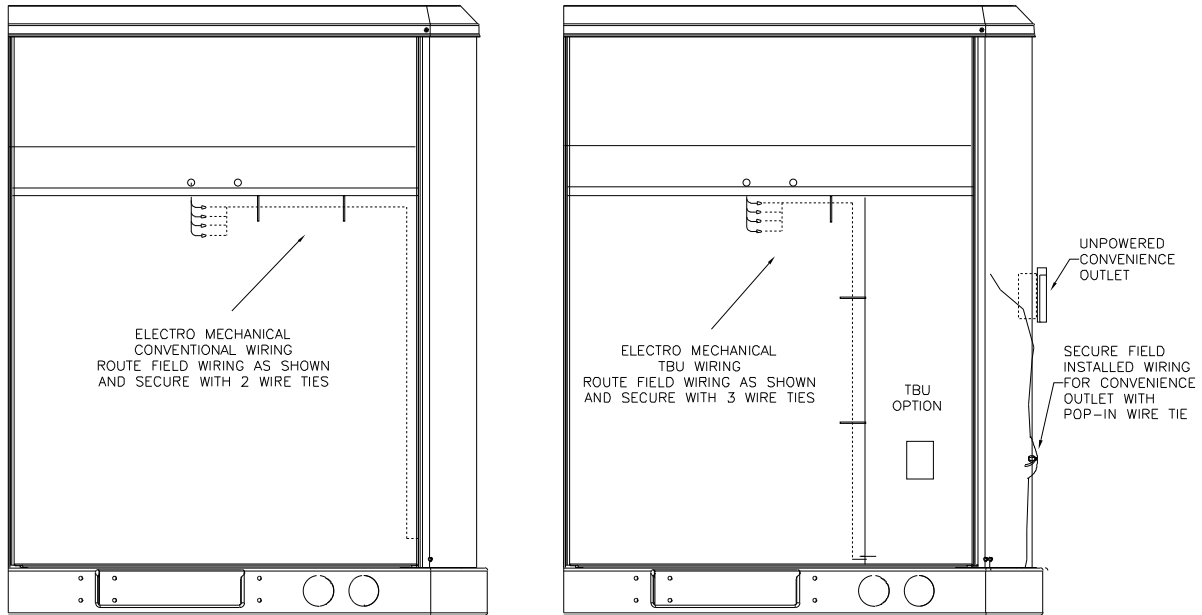


**Figure 31. ReliaTel humidistat (dehumidification option)**

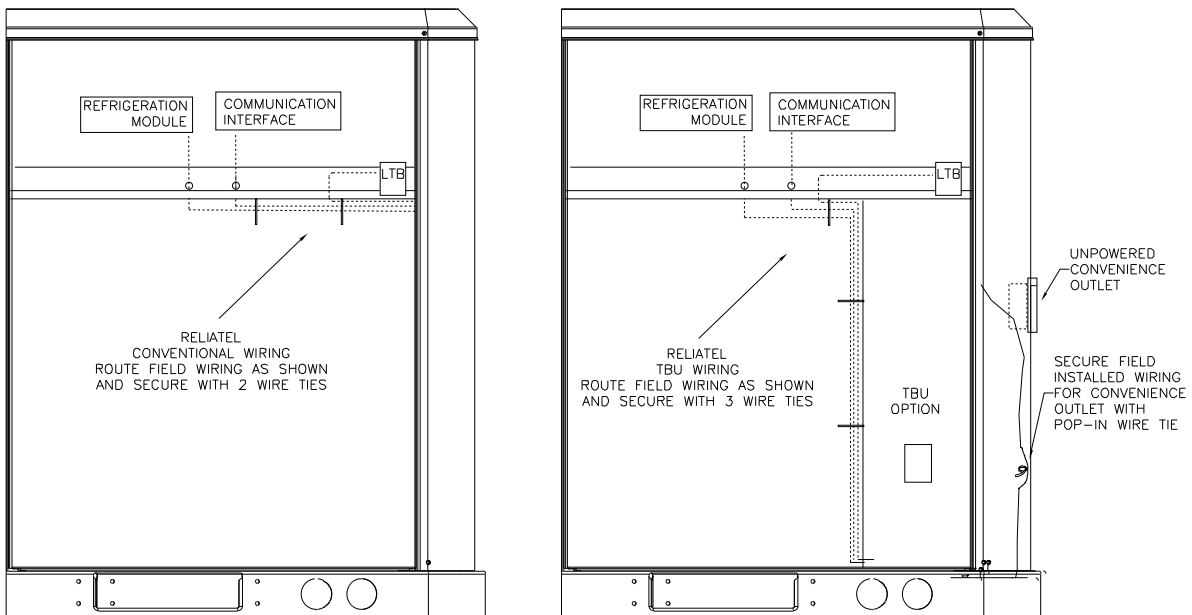


# Installation

**Figure 32. Electro mechanical control customer low voltage routing**



**Figure 33. ReliaTel control customer low voltage routing**



### Smoke Detector Customer Low Voltage Wiring

When interlocking System Sensor smoke detectors together, all of the detectors must be powered from the same power supply. If the smoke detectors are powered up by different power supplies, harmonics are set up and will fry the boards in some, if not all, of the detectors.

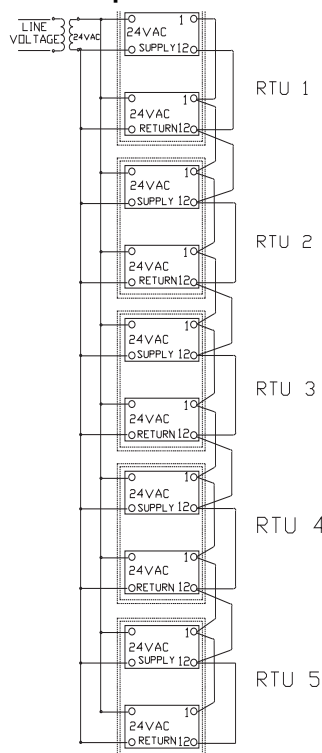
If multiple smoke detectors are required, all detectors must be disconnected from the HVAC unit power supply and connected together from another single source supply.

**Note:** Do not interconnect any smoke detectors together that have separate power supplies. Do not exceed ten smoke detectors on one power supply.

**Note:** Multiple System Sensor smoke detectors are connected together using terminals 1 and 12 on each detector.

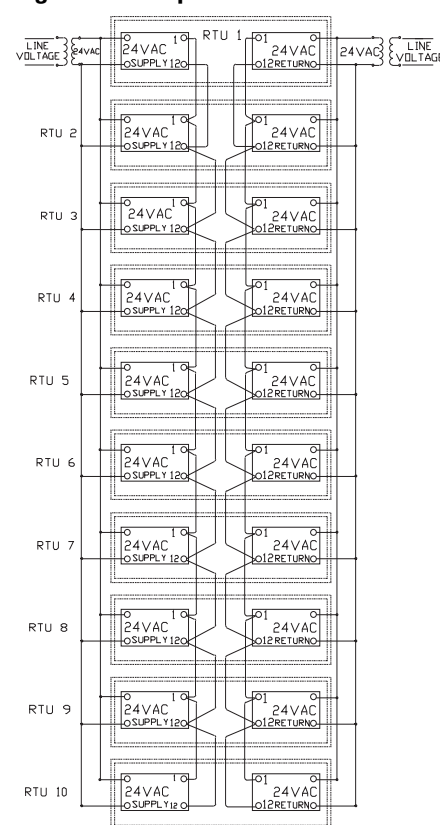
If you have supply and return smoke detectors in all HVAC units, you can connect a maximum of 5 HVAC units (10 detectors) up to one power supply. See the following field wiring example.

Figure 34. Up to 5 HVAC units



If you have more than 5 HVAC units, you can connect all the supplies together on one power supply (up to 10 HVAC units), and all the returns together (up to 10 HVAC units) on another power supply. See the following field wiring example.

Figure 35. Up to 10 HVAC units



# Installation

## Space Temperature Averaging

(ReliaTel™ only)

Space temperature averaging is accomplished by wiring a number of remote sensors in a series/parallel circuit.

Using the BAYSENS016\* or BAYSENS077\*, at least four sensors are required to accomplish space temperature averaging.

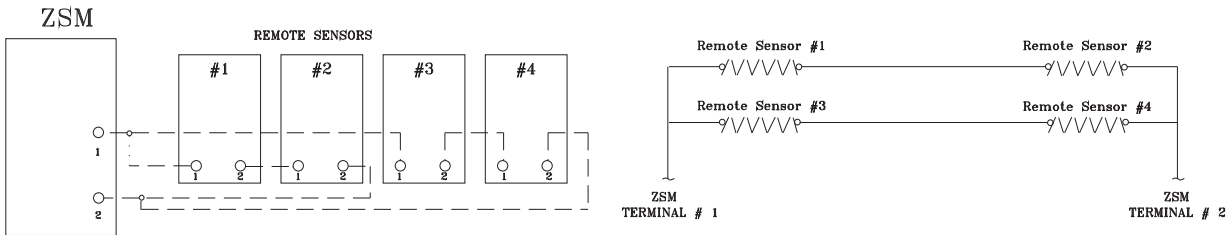
Example #1 illustrates two series circuits with two sensors in each circuit wired in parallel. The square of any number of remote sensors is required.

Example #2 illustrates three sensors squared in a series/parallel circuit. Using BAYSENS077\*, two sensors are required to accomplish space temperature averaging.

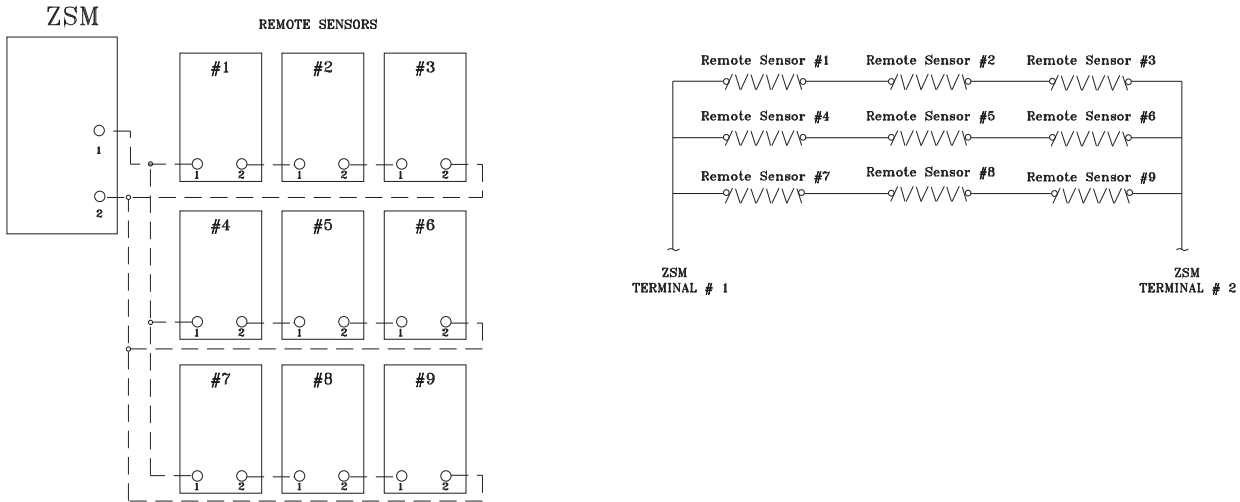
Example #3 illustrates the circuit required for this sensor. [Figure 7, p. 33](#) lists the temperature versus resistance coefficient for all sensors.

Figure 36. Examples

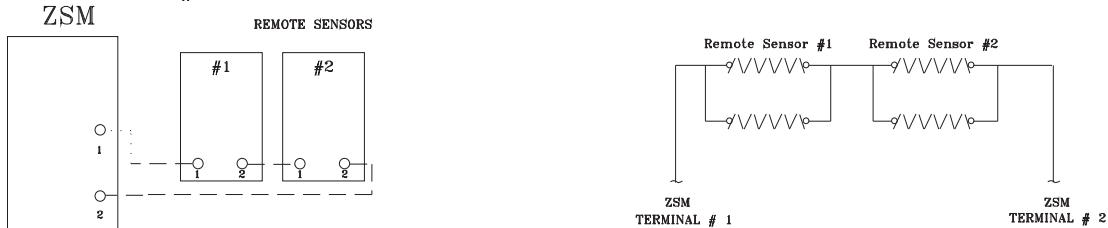
### EXAMPLE #1



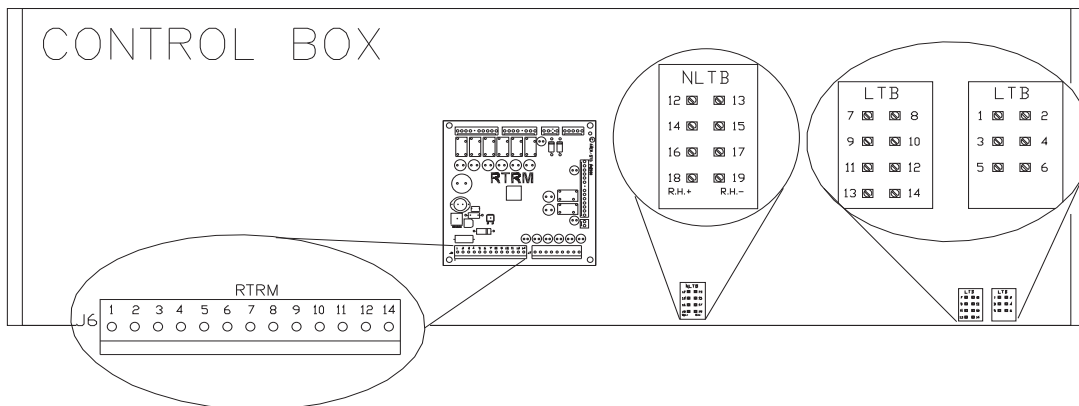
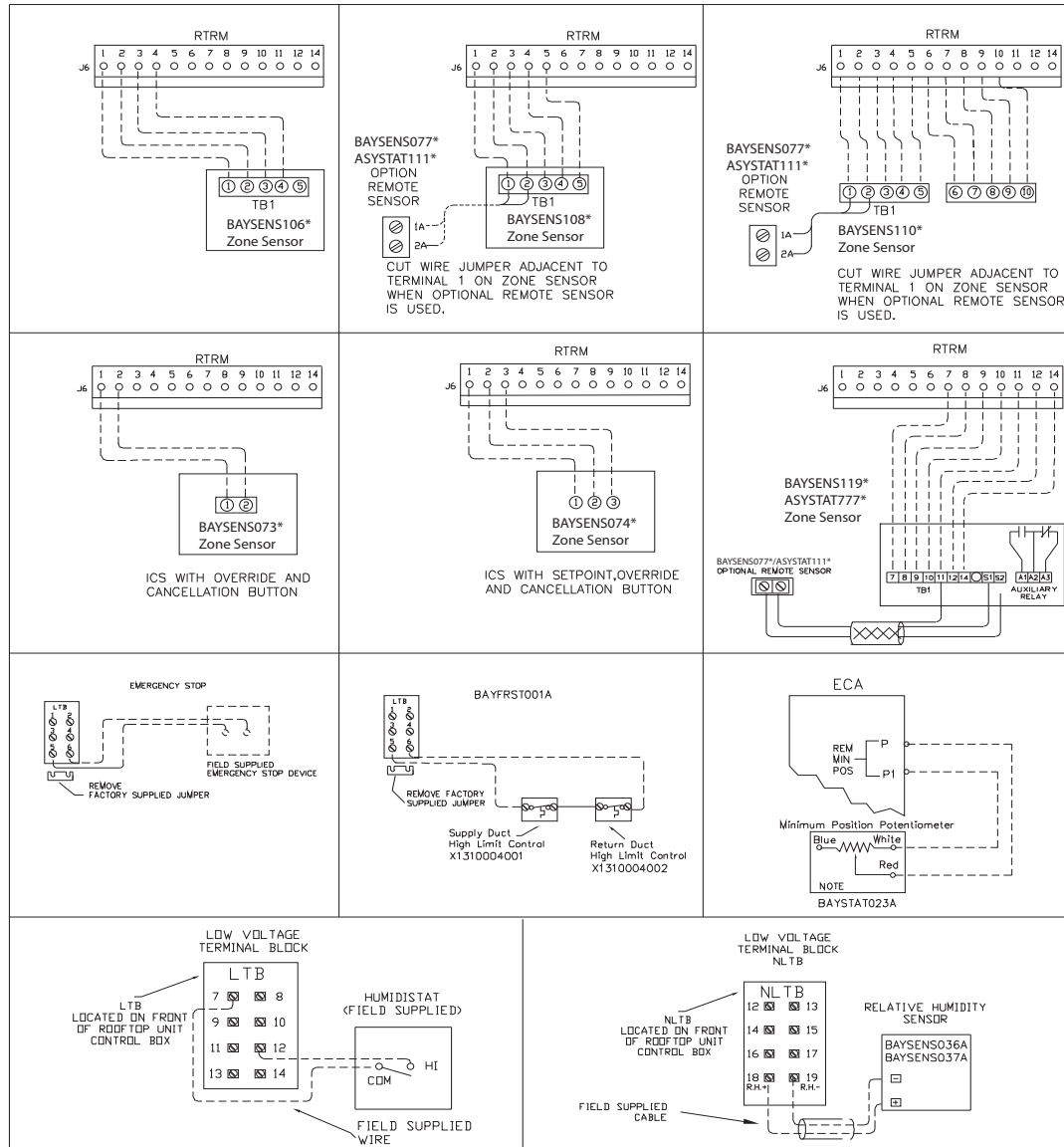
### EXAMPLE #2



### EXAMPLE #3



**Figure 37. Typical field wiring diagrams for optional controls (ReliaTel only)**



# Installation

**Table 7. Temperature vs. resistance**

Temperature		
Degrees F°	Degrees C°	Nominal Resistance
-20°	-28.9°	170.1 K - Ohms
-15°	-26.1°	143.5 K - Ohms
-10°	-23.3°	121.4 K - Ohms
-5°	-20.6°	103.0 K - Ohms
0°	-17.8°	87.56 K - Ohms
5°	-15.0°	74.65 K - Ohms
10°	-12.2°	63.80 K - Ohms
15°	-9.4°	54.66 K - Ohms
20°	-6.7°	46.94 K - Ohms
25°	-3.8°	40.40 K - Ohms
30°	-1.1°	34.85 K - Ohms
35°	1.7°	30.18 K - Ohms
40°	4.4°	26.22 K - Ohms
45°	7.2°	22.85 K - Ohms
50°	10.0°	19.96 K - Ohms
55°	12.8°	17.47 K - Ohms
60°	15.6°	15.33 K - Ohms
65°	18.3°	13.49 K - Ohms
70°	21.1°	11.89 K - Ohms
75°	23.9°	10.50 K - Ohms
80°	26.7°	9.297 K - Ohms
85°	29.4°	8.247 K - Ohms
90°	32.2°	7.330 K - Ohms
95°	35.0°	6.528 K - Ohms

**Table 8. Sizing natural gas pipe mains and branches**

Length of Pipe (Ft.)	Iron Pipe Size (IPS) Inches				
	1/2" Pipe	3/4" Pipe	1" Pipe	1 1/4" Pipe	1 1/2" Pipe
15	76	176	345	750	1220
30	52	120	241	535	850
45	43	99	199	435	700
60	38	86	173	380	610
75		77	155	345	545

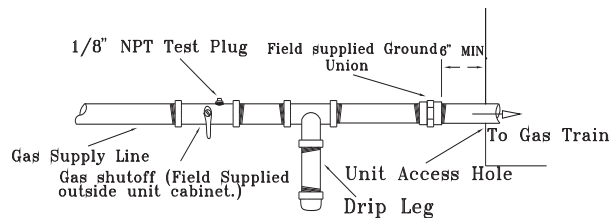
Capacity of Pipe of Different Diameters and Lengths in Cu. Ft. Per Hr. with Pressure Drop of 0.3" and Specific Gravity of 0.60

**Table 9. Iron pipe size (SI) millimeters**

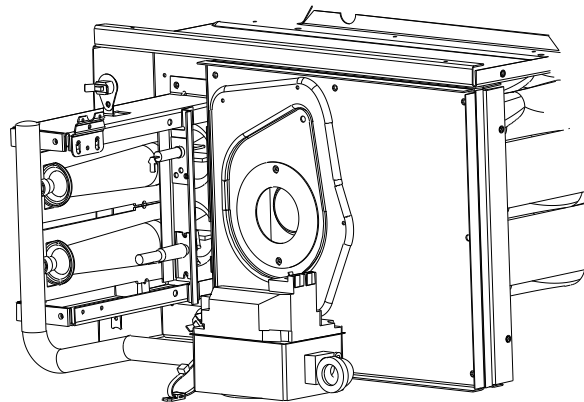
Length of Pipe (Meters)	Iron Pipe Size (SI) Millimeters				
	15 mm Pipe	20 mm Pipe	25 mm Pipe	32 mm Pipe	40 mm Pipe
4.6	2.15	4.98	9.76	21.23	34.54
9.1	1.47	3.39	6.82	15.14	24.06
13.7	1.21	2.80	5.63	12.31	19.82
18.3	1.07	2.43	4.89	10.76	17.27
22.9	—	2.18	4.38	9.76	15.40

Capacity of Pipe of Different Diameters and Lengths in Cu. Meter Per Hr. with Pressure Drop of 74.6 Pa and Specific Gravity of 0.60

**Figure 38. Schematic diagram for filed gas piping to unit**



**Figure 39. New TC01 location**



# Pre-Start

Use the checklist provided below in conjunction with the “General Unit Requirements” checklist to ensure that the unit is properly installed and ready for operation.

## **⚠️ WARNING** **Hazardous Voltage w/ Capacitors!**

**Disconnect all electric power, including remote disconnects and discharge all motor start/run capacitors before servicing. Follow proper lockout/tagout procedures to ensure the power cannot be inadvertently energized. Verify with an appropriate voltmeter that all capacitors have discharged. Failure to disconnect power and discharge capacitors before servicing could result in death or serious injury. Check all electrical connections for tightness and “point of termination” accuracy.**

Verify that the condenser airflow will be unobstructed.

## **⚠️ WARNING** **Rotating Components!**

**Disconnect all electric power, including remote disconnects before servicing. Follow proper lockout/tagout procedures to ensure the power can not be inadvertently energized. Failure to disconnect power before servicing could result in death or serious injury.**

- Verify that the condenser fan and indoor blower turn freely without rubbing and are properly tightened on the shafts.
- Check the supply fan belts for proper tension and the fan bearings for sufficient lubrication. If the belts require adjustment, or if the bearings need lubricating, refer to the maintenance section of this manual for instructions.
- Verify that a condensate trap is installed and the piping is properly sized and pitched.
- Verify that the correct size and number of filters are in place.
- Inspect the interior of the unit for tools and debris and install all

panels in preparation for starting the unit.

## **Voltage Imbalance**

Three phase electrical power to the unit must meet stringent requirements for the unit to operate properly.

Measure each leg (phase-to-phase) of the power supply. Each reading must fall within the utilization range stamped on the unit nameplate. If any of the readings do not fall within the proper tolerances, notify the power company to correct this situation before operating the unit.

Excessive three phase voltage imbalance between phases will cause motors to overheat and eventually fail. The maximum allowable voltage imbalance is 2%. Measure and record the voltage between phases 1, 2, and 3 and calculate the amount of imbalance as follows:

$$\% \text{ Voltage Imbalance} = 100 \times \frac{AV - VD}{AV} \text{ where;}$$

$$AV \text{ (Average Voltage)} = \frac{\text{Volt 1} + \text{Volt 2} + \text{Volt 3}}{3}$$

V1, V2, V3 = Line Voltage Readings

VD = Line Voltage reading that deviates the farthest from the average voltage.

- Example: If the voltage readings of the supply power measured 221, 230, and 227, the average volts would be:

$$\frac{221 + 230 + 227}{3} = 226 \text{ Avg.}$$

VD (reading farthest from average) = 221

The percentage of Imbalance equals:

$$100 \times \frac{226 - 221}{226} = 2.2\%$$

The 2.2% imbalance in this example exceeds the maximum allowable imbalance of 2.0%. This much imbalance between phases can

equal as much as a 20% current imbalance with a resulting increase in motor winding temperatures that will decrease motor life. If the voltage imbalance is over 2%, notify the proper agencies to correct the voltage problem before operating this equipment.

## **Electrical Phasing**

### **(Three Phase Motors)**

The compressor motor(s) and the supply fan motor are internally connected for the proper rotation when the incoming power supply is phased as A, B, C.

Proper electrical supply phasing can be quickly determined and corrected before starting the unit by using an instrument such as an Associated Research Model 45 Phase Sequence Indicator and following the steps below:

- Turn the field supplied disconnect switch that provides power to the main power terminal block or to the “Line” side of the optional factory mounted disconnect switch to the “Off” position.
- Connect the phase sequence indicator leads to the terminal block or to the “Line” side of the optional factory mounted disconnect switch as follows;

Black (phase A) to L1

Red (phase B) to L2

Yellow (phase C) to L3

- Close the field supplied main power disconnect switch or circuit protector switch that provides the supply power to the unit.

### **WARNING** **Live Electrical Components!**

**During installation, testing, servicing and troubleshooting of this product, it may be necessary to work with live electrical components. Have a qualified licensed electrician or other individual who has been properly trained in handling live electrical components perform these tasks. Failure to follow all electrical safety precautions when exposed to live electrical components could result in death or serious injury.**

To prevent injury or death from electrocution, it is the responsibility of the technician to recognize this hazard and use extreme care when performing service procedures with the electrical power energized.

- Observe the ABC and CBA phase indicator lights on the face of the sequencer. The ABC indicator light will glow if the phase is ABC. If the CBA indicator light glows, open the disconnect switch or circuit protection switch and reverse any two power wires.
- Restore the main electrical power and recheck the phasing. If the phasing is correct, open the disconnect switch or circuit protection switch and remove the phase sequence indicator.

### **Compressor Crankcase Heaters (Optional)**

Each compressor can be equipped with a crankcase heater. The proper operation of the crankcase heater is important to maintain an elevated compressor oil temperature during the "Off" cycle to reduce oil foaming during compressor starts. Oil foaming occurs when refrigerant condenses in the compressor and mixes with the oil. In lower ambient conditions, refrigerant migration to the compressor could increase.

When the compressor starts, the sudden reduction in crankcase pressure causes the liquid refrigerant to boil rapidly causing the oil to foam. This condition could damage compressor bearings due to reduced lubrication and could cause compressor mechanical failures.

Before starting the unit in the "Cooling" mode, set the system switch to the "Off" position and turn the main power disconnect to the "On" position and allow the crankcase heater to operate a minimum of 8 hours.

Before closing the main power disconnect switch, insure that the "System" selection switch is in the "Off" position and the "Fan" selection switch is in the "Auto" position.

Close the main power disconnect switch and the unit mounted disconnect switch, if applicable.

### **WARNING** **Live Electrical Components!**

**During installation, testing, servicing and troubleshooting of this product, it may be necessary to work with live electrical components. Have a qualified licensed electrician or other individual who has been properly trained in handling live electrical components perform these tasks. Failure to follow all electrical safety precautions when exposed to live electrical components could result in death or serious injury.**

To prevent injury or death from electrocution, it is the responsibility of the technician to recognize this hazard and use extreme care when performing service procedures with the electrical power energized.

### **ReliaTel™ Controls**

Upon power initialization, the RTRM performs self-diagnostic checks to insure that all internal controls are functional. It also checks the configuration parameters against the components connected to the system. The Liteport LED located on the RTRM module is turned "On" within one second of power-up if internal operation is okay.

Use one of the following "Test" procedure to bypass some time delays and to start the unit at the control panel. Each step of unit operation can be activated individually by temporarily shorting across the "Test" terminals for two to three seconds. The Liteport LED located on the RTRM module will blink when the test mode has been initiated. The unit can be left in any "Test" step for up to one hour before it will automatically terminate, or it can be terminated by opening the main power disconnect switch. Once the test mode has been terminated, the Liteport LED will glow continuously and the unit will revert to the "System" control.

**Table 10. Service test guide for component operation**

Test Step	Mode	Fan	Econ (Note 2)	Comp1	Comp 2	Heat 1	Heat 2	Ohms
1	Fan	On	Minimum Position Setpoint 0%	Off	Off	Off	Off	2.2K
	Minimum Ventilation	On	Selectable	Off	Off	Off	Off	
2	Economizer Test Open	On	Open	Off	Off	Off	Off	3.3K
3	Cool Stage 1	On	Minimum Position	(Note 1) On	Off	Off	Off	4.7K
4 (Note 3)	Cool Stage 2	On	Minimum Position	(Note 1) On	(Note 1) On	Off	Off	6.8K
5 (Note 3)	Reheat	On	Minimum	On	On	Off	Off	33K
6 (Note 3)	Heat Stage 1	On	Minimum	Off	Off	On	Off	10K
7 (Note 3)	Heat Stage 2	On	Minimum	Off	Off	On	On	15K

**Notes:**

- 1 - The condenser fans will operate any time a compressor is "On, providing the outdoor air temperatures are within the operating values.
- 2 - The exhaust fan will turn on anytime the economizer damper position is equal to or greater than the exhaust fan setpoint.
- 3 - Steps for optional accessories and non-applicable modes in unit will be skipped.

**Test Modes**

There are three methods in which the "Test" mode can be cycled at LTB-Test 1 and LTB-Test 2.

1. **Step Test Mode** - This method initiates the different components of the unit, one at a time, by temporarily shorting across the two test terminals for two to three seconds.  
For the initial start-up of the unit, this method allows the technician to cycle a component "On" and have up to one hour to complete the check.
2. **Resistance Test Mode** - This method can be used for start-up providing a decade box for variable resistance outputs is available. This method initiates the different components of the unit, one at a time, when a specific resistance value is placed across the two test terminals. The unit will remain in the specific test mode for approximately one hour even

though the resistance is left on the test terminals.

3. **Auto Test Mode** - This method is not recommended for start-up due to the short timing between individual component steps. This method initiates the different components of the unit, one at a time, when a jumper is installed across the test terminals. The unit will start the first test step and change to the next step every 30 seconds.

At the end of the test mode, control of the unit will automatically revert to the applied "System" control method.

For unit test steps, test modes, and step resistance values to cycle the various components, refer to [Table 10](#).

**Electro Mechanical Controls**

Upon power initialization, the Gas Ignition Module (IGN) performs self-diagnostic checks to insure that all internal controls are functional. It also checks the configuration parameters against the components connected to the system. The System LED located on the IGN module is turned "On" within one second of power-up if internal operation is okay.

**Electromechanical Controls Test Procedure**

See unit schematic for correct wire numbers.

**Fan Test and Minimum Ventilation**

Connect red thermostat wire (R) to black thermostat wire (G).

**Economizer Cooling**

Connect a jumper wire across OTS on Economizer Control (ECA).

Connect red thermostat (R) wire to yellow thermostat wire (Y1).

**Cool 1**

Connect red thermostat wire (R) to yellow thermostat wire (Y1).

**Cool 2**

Connect red thermostat wire (R) to yellow thermostat wire (Y2).

**Heat 1**

Connect red thermostat wire (R) to brown thermostat wire (W1).

**Heat 2**

Connect red thermostat wire (R) to brown thermostat wire (W2).

# Start-Up

## Verifying Proper Air Flow

### (Units with Two Speed Direct Drive Indoor Fan)

Much of the systems performance and reliability is closely associated with, and dependent upon having the proper airflow supplied both to the space that is being conditioned and across the evaporator coil.

The indoor fan motor is factory wired to operate on low speed in the cooling and heating mode. It can be rewired for high speed operation should the application require it. Refer to the wiring diagram that shipped in the unit.

The indoor fan motors are specifically designed to operate within the BHP parameters listed in the fan performance tables of the unit Service Facts. By understanding that these motors will safely work within these conditions, before an oversized motor is required, will allow the air distribution system to be set up properly and diagnostics enhanced should a problem occur.

When verifying direct drive fan performance, the tables must be used somewhat differently than those of belt driven fans. Fan performance diagnostics can be easily recognized when these tables are used correctly.

Before starting the SERVICE TEST, set the minimum position setpoint for the economizer to 0 percent using the setpoint potentiometer located on the Economizer Control (ECA), if applicable.

### ReliaTel™ Control

Using the Service Test Guide in [Table 10](#), momentarily jump across the Test 1 & Test 2 terminals on LTB1 one time to start the Minimum Ventilation Test.

### Electro Mechanical Control

Using the Service Test Guide perform the proper test mode connections.

With the fan operating properly, determine the total system external static pressure (inches w.c.) by;

1. Measuring the supply and return duct static pressure,
2. Using the accessory pressure drop table in the Service Facts, calculate the total static pressure drop for all of the accessories installed on the unit; i.e., curb, economizer, etc.

**Note:** *Static pressure is based on desired CFM and may not be actual static pressure.*

3. Add the total accessory static pressure drop (step 2) to the duct external static pressure (step 1). The sum of these two values represents the total system external static pressure.
4. Measure the amperage at the supply fan contactor and compare it with the full load amp (FLA) rating stamped on the motor nameplate.
  - a. Calculate the theoretical BHP

Actual Motor Amps X Motor HP

Motor Nameplate Amps

- b. Using the fan performance tables in the unit Service Facts, plot the total external static pressure (step 3) and the BHP (step 4a) to obtain the operating CFM.
- c. When plotted, if the two values can not be interpolated correspondingly, the static pressure will most likely be the least accurate measurement. Because of the direct drive motor operation, the RPM performance is relatively constant making the operating current a very reliable diagnostic tool.

- Example: W\_D060 single phase, low speed.

Actual Motor Amp (5.25) =.99%

Motor Nameplate Amps (5.3)

0.99 X Motor HP (0.6) =.59 BHP

The actual external static pressure is approximately 0.45" w.c., airflow equals 2100 CFM.

If the static pressure reading was higher, motor current would have to be lower proportionately to get an accurate CFM measurement in direct drive applications.

5. If the required CFM is too low, (external static pressure is high causing motor HP output to be below table value),
  - a. Relieve supply and/or return duct static.
  - b. Change indoor fan speed to "High" and repeat steps 1 through 4.
6. If the required CFM is too high, (external static pressure is low causing motor HP output to be above table value), increase supply and/or return duct static.
7. To stop the SERVICE TEST, turn the main power disconnect switch to the "Off" position or proceed to the next component start-up procedure.

## Verifying Proper Air Flow

### (Units with Belt Drive Indoor Fan)

Much of the systems performance and reliability is closely associated with, and dependent upon having the proper airflow supplied both to the space that is being conditioned and across the evaporator coil.

The indoor fan speed is changed by opening or closing the adjustable motor sheave.

Before starting the SERVICE TEST, set the minimum position setpoint for the economizer to 0 percent using the setpoint potentiometer located on the Economizer Control (ECA), if applicable.

### ReliaTel Control

Using the Service Test Guide in [Table 10](#), momentarily jump across the Test 1 & Test 2 terminals on LTB1 one time to start the Minimum Ventilation Test.

### Electro Mechanical Control

Using the Service Test Guide perform the proper test mode connections.

Once the supply fan has started, check for proper rotation. The direction of rotation is indicated by an arrow on the fan housing.

With the fan operating properly, determine the total system airflow (CFM) by;

1. Measuring the actual RPM,
2. Measure the amperage at the supply fan contactor and compare it with the full load amp (FLA) rating stamped on the motor nameplate.
  - a. Calculate the theoretical BHP

Actual Motor Amps X Motor HP

Motor Nameplate Amps

- b. Using the fan performance tables in the unit Service Facts, plot the actual RPM (step 1) and the BHP (step 2a) to obtain the operating CFM.
3. If the required CFM is too low, (external static pressure is high causing motor HP output to be below table value),
  - a. Relieve supply and/or return duct static.
  - b. Change indoor fan speed and repeat steps 1 and 2.
- To Increase Fan RPM; Loosen the pulley adjustment set screw and turn sheave clockwise.
- To Decrease Fan RPM; Loosen the pulley adjustment set screw and turn sheave counterclockwise.
- If the required CFM is too high, (external static pressure is low causing motor HP output to be above table value), change indoor fan speed and repeat steps 1 and 2.
- To stop the SERVICE TEST, turn the main power disconnect switch to the "Off" position or proceed to the next component start-up procedure.

### Verifying Proper Air Flow

#### (Units with 5-Tap Direct Drive Indoor Fan)

Much of the systems performance and reliability is closely associated with, and dependent upon having the proper airflow supplied both to the space that is being conditioned and across the evaporator coil.

The indoor fan motor is factory wired to operate on speed tap 1 in the cooling and heating mode for electric/electric units. For Gas/Electric units, the motor is factory wired to operate on speed tap 1 during cooling. For 3 & 4 ton Gas/Electric units operating in heat mode, the minimum setting is Tap 4.

For these units, a separate tap terminal is provided to change speeds automatically between heating and cooling. The motor can be rewired for different speed settings should the application require it. Refer to the wiring diagram that shipped in the unit and the unit fan performance tables in the Service Facts.

The indoor fan motors are specifically designed to operate within the BHP parameters listed in the fan performance tables of the unit Service Facts.

When verifying direct drive fan performance, the tables must be used somewhat differently than those of belt driven fans. Fan performance diagnostics can be easily recognized when these tables are used correctly.

Before starting the SERVICE TEST, set the minimum position setpoint for the economizer to 0 percent using the setpoint potentiometer located on the Economizer Control (ECA), if applicable.

#### ReliaTel Control

Using the Service Test Guide in [Table 10](#), momentarily jump across the Test 1 & Test 2 terminals on LTB1 one time to start the Minimum Ventilation Test.

### Electro Mechanical Control

Using the Service Test Guide perform the proper test mode connections.

With the fan operating properly, determine the total system external static pressure (inches w.c.) by the following method:

1. Measure the supply and return duct static pressure and sum the resulting absolute values,
2. Use the accessory pressure drop table in the Service Facts, to calculate the total static pressure drop for all of the accessories installed on the unit; i.e., curb, economizer, etc.

**Note:** *Accessory static pressure drop is based on desired CFM and may not be actual static pressure drop.*

3. Add the total accessory static pressure drop (step 2) to the duct external static pressure (step 1). The sum of these two values represents the total system external static pressure.

Using the Fan Performance Tables in the Service Facts, look up the selected speed tap setting and match the measured ESP to determine the approximate CFM.

If the required CFM is too low, (external static pressure is high) do one or both of the following and repeat procedure:

- a. Relieve supply and/or return duct static.
- b. Change indoor fan speed tap to a higher value

If the required CFM is too high, (external static pressure is low), do one or both of the following and repeat procedure:

- a. Increase supply and/or return duct static.
- b. Change indoor fan speed tap to a lower value.

**Note:** *Minimum setting for units with Gas or Electric Heat is 320 CFM per Ton. For 3 & 4 Ton Gas Heat units operating in heating mode the heat speed set cannot be lower than Speed Set 4.*

4. To stop the SERVICE TEST, turn the main power disconnect switch to the "Off" position or proceed to the next component start-up procedure.

### Return Air Smoke Detector

The return air smoke detector is designed to shut off the unit if smoke is sensed in the return air stream. Sampling the airflow entering the unit at the return air opening performs this function.

In order for the smoke detector to properly sense smoke in the return air stream, the air velocity entering the unit must be between 500 and 4000 feet per minute. Equipment covered in this manual will develop an airflow velocity that falls within these limits over the entire airflow range specified in the evaporator fan performance tables.

There are certain models however, if operated at low airflow, will not develop an airflow velocity that falls within the required 500 to 4000 feet per minute range. For these models, the design airflow shall be greater than or equal to the minimum CFM specified in the table provided below. Failure to follow these instructions will prevent the smoke detector from performing its design function.

### Economizer Start-Up

#### ReliaTel Control

Using the Service Test Guide in [Table 10](#), momentarily jump across the Test 1 & Test 2 terminals on LTB1 one time to start the Minimum Ventilation Test.

#### Electro Mechanical Control

Using the Service Test Guide perform the proper test mode connections.

1. Set the minimum position setpoint for the economizer to the required percentage of minimum ventilation using the setpoint potentiometer located on the Economizer Control (ECA).

The economizer will drive to its minimum position setpoint, exhaust fans (if applicable) may start at random, and the supply fan will start when the SERVICE TEST is initiated.

### WARNING Rotating Components!

**During installation, testing, servicing and troubleshooting of this product it may be necessary to measure the speed of rotating components. Have a qualified or licensed service individual who has been properly trained in handling exposed rotating components, perform these tasks. Failure to follow all safety precautions when exposed to rotating components could result in death or serious injury.**

The Exhaust Fan will start anytime the economizer damper position is equal to or greater than the exhaust fan setpoint.

2. Verify that the dampers stroked to the minimum position.

#### ReliaTel Control

Momentarily jump across the Test 1 & Test 2 terminals on LTB1 one additional time if continuing from previous component start-up or until the desired start-up component Test is started.

#### Electro Mechanical Control

Using the Service Test Guide perform the proper test mode connections.

3. Verify that the dampers stroked to the full open position.
4. To stop the SERVICE TEST, turn the main power disconnect switch to the "Off" position or proceed to the next component start-up procedure. Remove electro mechanical test mode connections (if applicable).

### Compressor Start-Up

1. Attach a set of service gauges onto the suction and discharge gauge ports for each circuit. Refer to the refrigerant circuit illustration in the Service Facts.

#### ReliaTel Control

Momentarily jump across the Test 1 & Test 2 terminals on LTB1 one additional time if continuing from previous component start-up or until the desired start-up component Test is started.

### Electro Mechanical Control

Using the Service Test Guide perform the proper test mode connections.

#### Scroll Compressors

- a. Once each compressor has started, verify that the rotation is correct. If a scroll compressor is rotating backwards, it will not pump and a loud rattling sound can be observed.
- b. If the electrical phasing is correct, before condemning a compressor, interchange any two leads (at the compressor Terminal block) to check the internal phasing. If the compressor runs backward for an extended period (15 to 30 minutes), the motor winding can overheat and cause the motor winding thermostat to open.

2. After the compressor and condenser fan have started and operated for approximately 30 minutes, observe the operating pressures. Compare the operating pressures to the operating pressure curve in the Service Facts.
3. Check system superheat. Follow the instruction listed on the superheat charging curve in the Service Facts.

Superheat should be within  $\pm 5$  F of the superheat chart value.

4. Repeat steps 1 through 4 for each refrigerant circuit.
5. To stop the SERVICE TEST, turn the main power disconnect switch to the "Off" position or proceed to the next component start-up procedure. Remove electro mechanical test mode connections (if applicable).

#### Dehumidification Option

Momentarily jump across the Test 1 and Test 2 terminals of the LTB1 until the unit enters test mode 7. (See [Table 6](#).) Once the unit is in the reheat test mode, verify that the 3 way valve has shifted to the reheat position and that the supply temperature rises 10 deg F more than when in cooling mode stage 2.

Monitor the suction pressure for 15 minutes. The suction pressure should remain within 5 psi of normal cooling operation. If the unit has a 2 speed Outdoor fan and if the Outdoor air temperature is below 70° F, verify that the OD fan is in low speed.

## Gas Heat Units

Open the main disconnect switch to shut the unit off and to reset the RTRM.

Follow the Test Guide in [Table 10](#) to start the unit in the heating mode. ReliaTel Control Momentarily jump across the Test 1 & Test 2 terminals on LTB1 one additional time if continuing from previous component start-up or until the desired start-up component Test is started.

## Electro Mechanical Control

Using the Service Test Guide perform the proper test mode connections

When starting the unit for the first time or servicing the heaters, it is a good practice to start the heater with the main gas supply turned "Off".

Once the ignition system and components have been checked, open the main power disconnect switch to reset the unit.

## Final System Setup

After completing all of the pre-start and start-up procedures outlined in the previous sections (i.e., operating the unit in each of its Modes through all available stages of cooling & heating), perform these final checks before leaving the unit:

- Program the Night Setback (NSB) panel (if applicable) for proper unoccupied operation. Refer to the programming instructions for the specific panel.
- Verify that the Remote panel "System" selection switch, "Fan" selection switch, and "Zone Temperature" settings for automatic operation are correct.
- Inspect the unit for misplaced tools, hardware, and debris.
- Verify that all exterior panels including the control panel doors and condenser grilles are secured in place.

- Close the main disconnect switch or circuit protector switch that provides the supply power to the unit's terminal block or the unit mounted disconnect switch.

## WARNING

### Live Electrical Components!

**During installation, testing, servicing and troubleshooting of this product, it may be necessary to work with live electrical components. Have a qualified licensed electrician or other individual who has been properly trained in handling live electrical components perform these tasks. Failure to follow all electrical safety precautions when exposed to live electrical components could result in death or serious injury.**

Make sure all personnel are standing clear of the unit before proceeding. The system components will start when the power is applied.

# Maintenance

## Fan Belt Adjustment - Belt Drive Units

### **⚠️ WARNING** Rotating Components!

Disconnect all electric power, including remote disconnects before servicing. Follow proper lockout/tagout procedures to ensure the power can not be inadvertently energized. Failure to disconnect power before servicing could result in death or serious injury.

The fan belts must be inspected periodically to assure proper unit operation.

Replacement is necessary if the belts appear frayed or worn. Units with dual belts require a matched set of belts to ensure equal belt length.

When removing or installing the new belts, do not stretch them over the sheaves. Loosen the belts using the belt tension adjustment bolts on the motor mounting base.

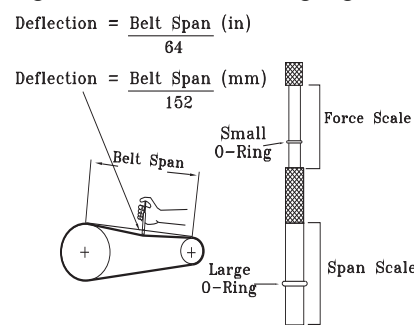
Once the new belts are installed, using a Browning or Gates tension gauge (or equivalent) illustrated in Figure 40; adjust the belt tension as follows;

- To determine the appropriate belt deflection;
  - Measure the center-to-center shaft distance (in inches) between the fan and motor sheaves.
  - Divide the distance measured in Step 1a by 64; the resulting value represents the amount of belt deflection that corresponds to the proper belt tension.
- Set the large O-ring on the belt tension gauge at the deflection value determined in Step 1b.
- Set the small O-ring at zero on the force scale of the gauge plunger.
- Place the large end of the gauge at the center of the belt span; then depress the gauge plunger until the large O-ring is even with the top of the next belt or

even with a straightedge placed across the fan and motor sheaves. Refer to Figure 9.

- Remove the belt tension gauge. The small O-ring now indicates a number other than zero on the plunger's force scale. This number represents the force (in pounds) required to give the needed deflection.
  - Compare the "force" scale reading (Step 5) with the appropriate "force" value listed in Table 7. If the "force" reading is outside the range, readjust the belt tension.
- Note:** Actual belt deflection "force" must not exceed the maximum "force" value shown in Figure 40.
- Recheck the belt tension at least twice during the first 2 to 3 days of operation. Belt tension may decrease until the new belts are "run in".

**Figure 40. Belt tension gauge**



**Table 11. Belt Tension Measurement and Deflection**

Belts Cross Section	Small P.D Range	Deflection Force (Lbs.)					
		Super Gripbelts		Gripnotch		Steel Cable Gripbelts	
		Min.	Max.	Min.	Max.	Min.	Max.
A	3.0 - 3.6	3	4 1/2	3 7/8	5 1/2	3 1/4	4
	3.8 - 4.8	3 1/2	5	4 1/2	6 1/4	3 3/4	4 3/4
	5.0 - 7.0	4	5 1/2	5	6 7/8	4 1/4	5 1/4
B	3.4 - 4.2	4	5 1/2	5 3/4	8	4 1/2	5 1/2
	4.4 - 5.6	5 1/8	7 1/8	6 1/2	9 1/8	5 3/4	7 1/4
	5.8 - 8.8	6 3/8	8 3/4	7 3/8	10 1/8	7	8 3/4

## Monthly Maintenance

Before completing the following checks, turn the unit OFF and lock the main power disconnect switch open.

### **⚠️ WARNING** Rotating Components!

Disconnect all electric power, including remote disconnects before servicing. Follow proper lockout/tagout procedures to ensure the power can not be inadvertently energized. Failure to disconnect power before servicing could result in death or serious injury.

Failure to disconnect power before servicing can cause severe personal injury or death.

## Filters

- Inspect the return air filters. Clean or replace them if necessary. Refer to the unit Service Facts for filter information.

## Filters

Inspect the return air filters. Clean or replace them if necessary. Refer to the unit Service Facts for filter information.

## Return Air Smoke Detector Maintenance

Airflow through the unit is affected by the amount of dirt and debris accumulated on the indoor coil and filters. To insure that airflow through the unit is adequate for proper sampling by the return air smoke

detector, complete adherence to the maintenance procedures, including recommended intervals between filter changes, and coil cleaning is required.

Periodic checks and maintenance procedures must be performed on the smoke detector to insure that it will function properly. For detailed instructions concerning these checks and procedures, refer to the appropriate section(s) of the smoke detector Installation and Maintenance Instructions provided with the literature package for this unit.

## Cooling Season

- Check the unit's drain pans and condensate piping to ensure that there are no blockages.
- Inspect the evaporator and condenser coils for dirt, bent fins, etc. If the coils appear dirty, clean them according to the instructions described in "Coil Cleaning" later in this section.
- Manually rotate the condenser fan(s) to ensure free movement and check motor bearings for wear. Verify that all of the fan mounting hardware is tight.
- Inspect the F/A-R/A damper hinges and pins to ensure that all moving parts are securely mounted. Keep the blades clean as necessary.
- Verify that all damper linkages move freely; lubricate with white grease, if necessary.
- Check supply fan motor bearings; repair or replace the motor as necessary.
- Check the fan shaft bearings for wear. Replace the bearings as necessary.
- Check the supply fan belt. If the belt is frayed or worn, replace it. Refer to the "Fan Belt Adjustment" section for belt replacement and adjustments.
- Verify that all wire terminal connections are tight.
- Remove any corrosion present on the exterior surfaces of the unit and repaint these areas.

- Generally inspect the unit for unusual conditions (e.g., loose access panels, leaking piping connections, etc.)
- Make sure that all retaining screws are reinstalled in the unit access panels once these checks are complete.
- With the unit running, check and record the: ambient temperature; compressor suction and discharge pressures (each circuit); superheat (each circuit);
- Record this data on an "operator's maintenance log" like the one shown in [Table 12 on page 44](#). If the operating pressures indicate a refrigerant shortage, measure the system superheat. For guidelines, refer to the "Compressor Start-Up" section.

**Note:** *Do Not release refrigerant to the atmosphere! If adding or removing refrigerant is required, the service technician must comply with all federal, state and local laws.*

## Heating Season

- Inspect the unit's air filters. If necessary, clean or replace them.
- Check supply fan motor bearings; repair or replace the motor as necessary.
- Inspect both the main unit control panel and heat section control box for loose electrical components and terminal connections, as well as damaged wire insulation. Make any necessary repairs.
- Clean burner area, verify gas heat system operates properly.

## Coil Cleaning

Regular coil maintenance, including annual cleaning, enhances the unit's operating efficiency by minimizing: compressor head pressure and amperage draw; evaporator water carryover; fan brake horsepower, due to increase static pressure losses; airflow reduction.

At least once each year, or more often if the unit is located in a "dirty" environment, clean the evaporator

and condenser coils using the instructions outlined below. Be sure to follow these instructions as closely as possible to avoid damaging the coils.

**Note:** *For units equipped with hail guards follow removal procedure listed below.*

## Hail Guard Removal

- Unlatch hail guard.
- Pull the top of the hail guard outward until the fastener studs are free of the retaining nuts.
- Lift the hail guard from the lower retaining bracket and set aside.

To clean refrigerant coils, use a soft brush and a sprayer (either a garden pump-up type or a high-pressure sprayer). A high-quality detergent is also required; suggested brands include "SPREX A.C.," "OAKITE 161," "OAKITE 166" and "COILOX." If the detergent selected is strongly alkaline (ph value exceeds 8.5), add an inhibitor.

## WARNING Hazardous Chemicals!

**Coil cleaning agents can be either acidic or highly alkaline. Handle chemical carefully. Proper handling should include goggles or face shield, chemical resistant gloves, boots, apron or suit as required. For personal safety refer to the cleaning agent manufacturer's Materials Safety Data Sheet and follow all recommended safe handling practices. Failure to follow all safety instructions could result in death or serious injury.**

1. Remove enough panels from the unit to gain access to the coil.
2. Protect all electrical devices such as motors and controllers from any over spray.
3. Straighten any bent coil fins with a fin comb.
4. Mix the detergent with water according to the manufacturer's instructions. If desired, heat the solution BUT DO NOT EXCEED 150 F maximum to improve its cleansing capability.

## Maintenance

### **⚠️ WARNING** **Hazardous Pressures!**

Coils contain refrigerant under pressure. When cleaning coils, maintain coil cleaning solution temperature under 150°F to avoid excessive pressure in the coil. Failure to follow these safety precautions could result in coil bursting, which could result in death or serious injury.

Do not heat the detergent-and-water solution above 150° F. Hot liquids sprayed on the exterior of the coil will raise the coil's internal pressure and may cause it to burst. Failure to follow proper procedures can result in personal illness or injury or severe equipment damage.

5. Pour the cleaning solution into the sprayer. If a high-pressure sprayer is used:
  - a. do not allow sprayer pressure to exceed 600 psi.
  - b. the minimum nozzle spray angle is 15 degrees.
  - c. maintain a minimum clearance of 6" between the sprayer nozzle and the coil.
  - d. spray the solution perpendicular (at 90 degrees) to the coil face.
6. Spray the leaving-airflow side of the coil first; then spray the opposite side of the coil. Allow the cleaning solution to stand on the coil for five minutes.
7. Rinse both sides of the coil with cool, clean water.
8. Inspect both sides of the coil; if it still appears to be dirty, repeat Steps 6 and 7.
9. Reinstall all of the components and panels removed in Step 1 and any protective covers installed in step 2.

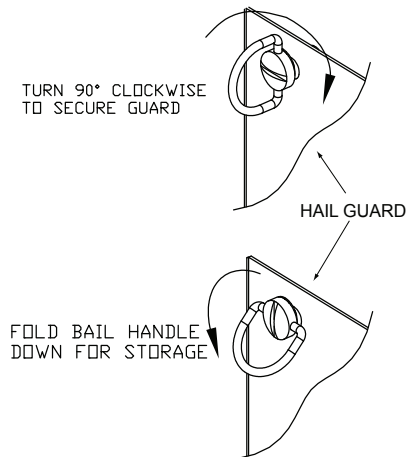
**Note:** For units equipped with hail guards follow reinstallation procedure listed below.

#### **Hail Guard Reinstallation**

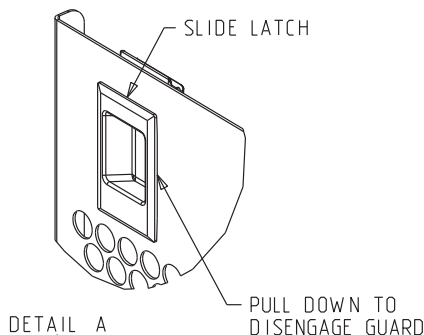
- To reinstall the hail guard, locate the bottom of the hail guard in the lower bracket and secure it to the upper unit bracket with the attached fasteners.

**Note:** Secure hail guard latches.

**Figure 41.**



**Figure 42.**



10. Restore the unit to its operational status and check system operation.

#### **For units with the Dehumidification Option**

For access to the leaving face of the evaporator, locate the reheat coil, locking bracket above the reheat coil. This bracket attaches the reheat coil to the Evaporator top block off. Initially there are 2 screws approximately 2 inches from the top of the unit.

Remove and discard the screw on the left, which is in place for shipping. Loosen the screw on the right. Do not remove. Slide the locking bracket towards the front of the unit to unlock the coil. Pivot the reheat coil to the vertical position to access the evaporator face.

**Note:** Clean the reheat coil on the same interval and method as the evaporator coil.

Replace the reheat coil to its proper location once cleaning is complete. Align the screw heads in the top of the reheat coil with the slots in the evaporator top block off. Press the coil assembly into place and verify that the reheat coil is flush against the evaporator top block off. Set the locking bracket on the top of the reheat coil flush with the evaporator coil top block off.

Apply pressure to the center of the bracket and slide the bracket towards the rear of the unit. Tighten the screw to secure the bracket and the coil in place.

**Annual Maintenance**

- Clean and repaint any corroded surface.

**Final Process**

For future reference, you may find it helpful to record the unit data requested in the blanks provided.

**Complete Model Number**

---

**Unit Serial Number**

---

**Wiring Diagram Numbers (from unit control panel)**

---

**Schematics**

---

**Connections**

---

**Table 12. Sample maintenance log**

Date	Refrigerant Circuit #1							Refrigerant Circuit #2					
	Current Ambient Temp. F/C	Compr. Oil Level	Suct. Press. Psig/kPa	Disch. Press. Psig/kPa	Liquid Press. Psig/kPa	Superheat F/C	Sub-cool. F/C	Compr. Oil Level	Suct. Press. Psig/kPa	Disch. Press. Psig/kPa	Liquid Press. Psig/kPa	Superheat F/C	Sub-cool. F/C
		- ok - low						- ok - low					
		- ok - low						- ok - low					
		- ok - low						- ok - low					
		- ok - low						-- ok - low					
		- ok - low						- ok - low					
		- ok - low						- ok - low					
		- ok - low						- ok - low					
		- ok - low						- ok - low					
		- ok - low						- ok - low					
		- ok - low						- ok - low					
		- ok - low						- ok - low					

Note: Check and record the data requested above each month during the cooling season with the unit running.

# Trouble Shooting

## ReliaTel™ Control

The RTRM has the ability to provide the service personnel with some unit diagnostics and system status information.

Before turning the main power disconnect switch "Off", follow the steps below to check the ReliaTel Refrigeration Module (RTRM). All diagnostics & system status information stored in the RTRM will be lost when the main power is turned "Off".

### **WARNING** **Live Electrical Components!**

**During installation, testing, servicing and troubleshooting of this product, it may be necessary to work with live electrical components. Have a qualified licensed electrician or other individual who has been properly trained in handling live electrical components perform these tasks. Failure to follow all electrical safety precautions when exposed to live electrical components could result in death or serious injury.**

To prevent injury or death from electrocution, it is the responsibility of the technician to recognize this hazard and use extreme care when performing service procedures with the electrical power energized.

1. Verify that the Liteport LED on the RTRM is burning continuously. If the LED is lit, go to Step 3.
2. If the LED is not lit, verify that 24 VAC is present between J1-1 and J1-2. If 24 VAC is present, proceed to Step 3. If 24 VAC is not present, check the unit main power supply, check transformer (TNS1). Proceed to Step 3 if necessary.
3. Utilizing "Method 1" or "Method 2" in the "System Status Diagnostic" section, check the following:
  - System status
  - Heating status
  - Cooling status

If a System failure is indicated, proceed to Step 4. If no failures are indicated, proceed to Step 5.

4. If a System failure is indicated, recheck Steps 1 and 2. If the LED is not lit in Step 1, and 24 VAC is present in Step 2, the RTRM has failed. Replace the RTRM.
5. If no failures are indicated, use one of the TEST mode procedures described in the "Unit Start-Up" section to start the unit. This procedure will allow you to check all of the RTRM outputs, and all of the external controls (relays, contactors, etc.) that the RTRM outputs energize, for each respective mode. Proceed to Step 6.
6. Step the system through all of the available modes, and verify operation of all outputs, controls, and modes. If a problem in operation is noted in any mode, you may leave the system in that mode for up to one hour while troubleshooting. Refer to the sequence of operations for each mode, to assist in verifying proper operation. Make the necessary repairs and proceed to Steps 7 and 8.
7. If no abnormal operating conditions appear in the test mode, exit the test mode by turning the power "Off" at the main power disconnect switch.
8. Refer to the individual component test procedures if other microelectronic components are suspect.

## System Status Checkout Procedure

"System Status" is checked by using one of the following two methods:

### Method 1

If the Zone Sensor Module (ZSM) is equipped with a remote panel with LED status indication, you can check the unit within the space. If the ZSM does not have LED's, use Method 2.

BAYSENS110\*, BAYSENS109\*, BAYSENS119\*, BAYSENS023A all have the remote panel indication feature. The LED descriptions are listed below.

### LED 1 (System)

"On" during normal operation.

"Off" if a system failure occurs or the LED fails.

"Flashing" indicates test mode.

### LED 2 (Heat)

"On" when the heat cycle is operating.

"Off" when the heat cycle terminates or the LED fails.

"Flashing" indicates a heating failure.

### LED 3 (Cool)

"On" when the cooling cycle is operating.

"Off" when the cooling cycle terminates or the LED fails.

"Flashing" indicates a cooling failure.

### LED 4 (Service)

"On" indicates a clogged filter.

"Off" during normal operation.

"Flashing" indicates an evaporator fan failure

Below is the complete listing of failure indication causes.

## System failure

Check the voltage between terminals 6 and 9 on J6, it should read approximately 32 VDC. If no voltage is present, a System failure has occurred. Refer to Step 4 in the previous section for the recommended troubleshooting procedure.

## Heating Failure

Verify Heat Failure by Ignition Module (IGN) LED indicator:

**OFF:** No Power or Failure

**ON:** Normal

**Slow Flash:** Normal, Heat Call

**Fast Flash:** Error Code:

**1 Flash:** Communication Failure

**2 Flashes:** System Lockout

**3 Flashes:** Pressure Switch Fail

**4 Flashes:** TC01 or TC02 Open

**5 Flashes:** Flame w/o Gas Valve

**6 Flashes:** Flame Rollout Open

## Cooling Failure

1. Cooling and heating set point (slide pot) on the zone sensor has failed. Refer to the "Zone Sensor Test Procedure" section.
2. Zone temperature thermistor ZTEMP on ZTS failed. Refer to the "Zone Sensor Test Procedure" section.
3. CC1 or CC2 24 VAC control circuit has opened, check CC1 & CC2 coils, and any of the controls below that apply to the unit (HPC1, HPC2).
4. LPC1 has opened during the 3 minute minimum "on time" during 4 consecutive compressor starts, check LPC1 or LPC2 by testing voltage between the J1-1 & J3-2 terminals on the RTRM and ground. If 24 VAC is present, the LPC's has not tripped. If no voltage is present, LPC's has tripped.

## Service Failure

1. If the supply fan proving switch has closed, the unit will not operate (when connected to RTOM), check the fan motor, belts, and proving switch.
2. Clogged filter switch has closed, check the filters.

## Simultaneous Heat and Cool Failure

1. Emergency Stop is activated

## Method 2

The second method for determining system status is done by checking voltage readings at the RTRM (J6). The system indication descriptions and the approximate voltages are listed below.

## System Failure

Measure the voltage between terminals J6-9 & J6-6.

Normal Operation = approximately 32 VDC

System Failure = less than 1 VDC, approximately 0.75 VDC

Test Mode = voltage alternates between 32 VDC & 0.75 VDC

## Heat Failure

Measure the voltage between terminals J6-7 & J6-6.

Heat Operating = approximately 32 VDC

Heat Off = less than 1 VDC, approximately 0.75 VDC

Heating Failure = voltage alternates between 32 VDC & 0.75 VDC

## Cool Failure

Measure the voltage between terminals J6-8 & J6-6.

Cool Operating = approximately 32 VDC

Cool Off = less than 1 VDC, approximately 0.75 VDC

Cooling Failure = voltage alternates between 32 VDC & 0.75 VDC

## Service Failure

Measure the voltage between terminals J6-10 & J6-6.

Clogged Filter = Approximately 32 VDC.

Normal = Less than 1 VDC, approximately 0.75 VDC Fan Failure = voltage alternates between 32 VDC & 0.75 VDC.

To use LED's for quick status information at the unit, purchase a BAYSENS110\* ZSM and connect wires with alligator clamps to terminals 6 through 10. Connected each respective terminal wire (6 through 10) from the Zone Sensor to the unit J6 terminals 6 through 10.

**Note:** If the system is equipped with a programmable zone sensor, BAYSENS119\* the LED indicators will not function while the BAYSENS110\* is connected.

## Resetting Cooling and Ignition Lockouts

Cooling Failures and Ignition Lockouts are reset in an identical manner. Method 1 explains resetting the system from the space; Method 2 explains resetting the system at the unit.

**Note:** Before resetting Cooling Failures and Ignition Lockouts check the Failure Status Diagnostics by the methods previously explained. Diagnostics will be lost when the power to the unit is disconnected.

## Method 1

To reset the system from the space, turn the "Mode" selection switch at the zone sensor to the "Off" position. After approximately 30 seconds, turn the "Mode" selection switch to the desired mode, i.e. Heat, Cool or Auto.

## Method 2

To reset the system at the unit, cycle the unit power by turning the disconnect switch "Off" and then "On".

Lockouts can be cleared through the building management system. Refer to the building management system instructions for more information.

## Zone Temperature Sensor (ZTS) Service Indicator

The ZSM SERVICE LED is a generic indicator, that will signal the closing of a Normally Open switch at any time, providing the Indoor Motor (IDM) is operating. This indicator is usually used to indicate a clogged filter, or an air side fan failure.

The RTRM will ignore the closing of this Normally Open switch for 2 (±1) minutes. This helps prevent nuisance SERVICE LED indications. The exception is the LED will flash 40 seconds after the fan is turned "On" if the Fan Proving Switch is not made.

# Trouble Shooting

## Clogged Filter Switch

This LED will remain lit the entire time that the Normally Open switch is closed. The LED will be turned off immediately after resetting the switch (to the Normally Open position), or any time that the IDM is turned "Off".

If the switch remains closed, and the IDM is turned "On", the SERVICE LED will be turned "On" again after the 2 (±1) minute ignore delay.

This LED being turned "On", will have no other affect on unit operation. It is an indicator only.

## Fan Failure Switch

When the "Fan Failure" switch is wired to the RTOM, the LED will remain flashing the entire time the fan proving switch is closed, indicating a fan failure, and it will shut the unit operations down.

## Zone Temperature Sensor (ZTS) Test

**Note:** *These procedures are not for programmable or digital models and are conducted with the Zone Sensor Module electrically removed from the system.*

### Test 1 - Zone Temperature Thermistor (ZTEMP)

This component is tested by measuring the resistance between terminals 1 and 2 on the Zone Temperature Sensor. Below are some typical indoor temperatures, and corresponding resistive values.

## Test 2 - Cooling Set Point (CSP) and Heating Set Point (HSP)

**Table 13. Cooling setpoint and heating setpoint**

Zone Temperature		Nominal ZTEMP Resistance
50 F°	10.0 C°	19.9 K-Ohms
55 F°	12.8 C°	17.47 K-Ohms
60 F°	15.6 C°	15.3 K-Ohms
65 F°	18.3 C°	13.49 K-Ohms
70 F°	21.1 C°	11.9 K-Ohms
75 F°	23.9 C°	10.50 K-Ohms
80 F°	26.7 C°	9.3 K-Ohms
85 F°	29.4 C°	8.25 K-Ohms
90 F°	32.2 C°	7.3 K-Ohms

The resistance of these potentiometers are measured between the following ZSM terminals. Refer to the chart above for approximate resistances at the given setpoints.

Cool SP = Terminals 2 and 3

Range = 100 to 900 Ohms approximate

Heat SP = Terminals 2 and 5

Range = 100 to 900 Ohms approximate

### Test 3 - System Mode and Fan Selection

The combined resistance of the Mode selection switch and the Fan selection switch can be measured between terminals 2 and 4 on the Zone Sensor. The possible switch combinations are listed below with their corresponding resistance values.

### Test 4 - LED Indicator Test, (SYS ON, HEAT, COOL & SERVICE)

#### Method 1

Testing the LED using a meter with diode test function. Test both forward and reverse bias. Forward bias should measure a voltage drop of 1.5 to 2.5 volts, depending on your meter. Reverse bias will show an Over Load, or open circuit indication if LED is functional.

#### Method 2

Testing the LED with an analog Ohmmeter. Connect Ohmmeter across LED in one direction, then reverse the leads for the opposite direction. The LED should have at least 100 times more resistance in reverse direction, as compared with the forward direction. If high resistance in both directions, LED is open. If low in both directions, LED is shorted.

#### Method 3

To test LED's with ZSM connected to unit, test voltages at LED terminals on ZSM. A measurement of 32 VDC, across an unlit LED, means the LED has failed.

## Relative Humidity Sensor Test

This component is measured by measuring the mA output signal on the Relative Humidity Sensor. Verify accuracy of the sensor annually. If the output reading is 0 mA, first verify that power is applied to the sensor. A reading of 4 mA corresponds to 0% RH and 20 mA corresponds to 100% RH.

% RH	mA
30	8.8
40	10.4
50	12.0
60	13.6
70	15.2
80	16.8

**Note:** *Measurements should be made from LED common (ZSM terminal 6 to respective LED terminal). Refer to the Zone Sensor Module (ZSM) Terminal Identification table at the beginning of this section.*

## Programmable & Digital Zone Sensor Test

Testing serial communication voltage

1. Verify 24 VAC is present between terminals J6-14 & J6-11.
2. Disconnect wires from J6-11 and J6-12. Measure the voltage between J6-11 and J6-12, should be about 32 VDC.

3. Reconnect wires to terminals J6-11 and J6-12. Measure voltage again between J6-11 and J6-12, voltage should flash high and low every 0.5 seconds. The voltage on the low end will measure about 19 VDC, while the voltage on the high end will measure from approximately 24 to 38 VDC.
4. Verify all modes of operation, by running the unit through all of the steps in the "Test Modes" section discussed in "Unit Start-Up".
5. After verifying proper unit operation, exit the test mode. Turn the fan on continuously at the ZSM, by pressing the button with the fan symbol. If the fan comes on and runs continuously, the ZSM is good. If you are not able to turn the fan on, the ZSM is defective.

## ReliaTel Refrigeration Module (RTRM) Default Chart

If the RTCI loses input from the building management system, the RTRM will control in the default mode after approximately 15 minutes. If the RTRM loses the Heating and Cooling setpoint input, the RTRM will control in the default mode instantaneously. The temperature sensing thermistor in the Zone Sensor Module is the only component required for the "Default Mode" to operate.

## Unit Operation without a Zone Sensor

This procedure is for temporary operation only. The economizer and condenser fan cycling functions are disabled.

1. Open and Lock the unit disconnect switch.
2. Remove the Outside Air Sensor (OAS) from the condenser section of unit.
3. Use two (2) wire nuts, to individually cap the wires.
4. Locate the RTRM (J6). Connect two (2) wires to terminals J6-1 and 2.
5. Connect the sensor (OAS) using two wire nuts to the two (2) field

supplied wires that were connected to terminals 1 and 2 on J6.

## Unit Economizer Control (ECA) Troubleshooting

### ReliaTel Control

Verify Economizer Status by Economizer Actuator (ECA) LED indicator:

OFF: No Power or Failure

ON: Normal, OK to Economize

Slow Flash: Normal, Not OK to Economize

Fast Flash - 1/2 Second On / 2 Seconds Off:

Error Code:

Communications Failure

Pulse Flash: 2 Seconds On / 1/2 Second Off:

Error Code:

1 Flash: Actuator Fault

2 Flashes: CO<sub>2</sub> Sensor

3 Flashes: RA Humidity Sensor

4 Flashes: RA Temp Sensor

5 Flashes: OA Quality Sensor

6 Flashes: OA Humidity Sensor

7 Flashes: OA Temp Sensor

8 Flashes: MA Temp Sensor

9 Flashes: RAM Fault

10 Flashes: ROM Fault

11 Flashes: EEPROM Fault

### Electro Mechanical Control

The IGN has the ability to provide the service personnel with some unit diagnostics and system status information.

Before turning the main power disconnect switch "Off", follow the steps below to check the Ignition Module (IGN).



## WARNING Live Electrical Components!

During installation, testing, servicing and troubleshooting of this product, it may be necessary to work with live electrical components. Have a qualified licensed electrician or other individual who has been properly trained in handling live electrical components perform these tasks. Failure to follow all electrical safety precautions when exposed to live electrical components could result in death or serious injury.

To prevent injury or death from electrocution, it is the responsibility of the technician to recognize this hazard and use extreme care when performing service procedures with the electrical power energized.

1. Verify that the LED on the IGN is burning continuously. If the LED is lit, go to Step 3.
2. If the LED is not lit, verify that 24 VAC is present between R and B. If the LED is not lit and 24 VAC is present replace the IGN. If 24 VAC is not present, check transformer (TNS1). Proceed to Step 3 if necessary.
3. If no failures are indicated, use the TEST mode procedures described in the "Unit Start-Up" section or thermostat to start the unit. This procedure will allow you to check all of the external controls (relays, contactors, etc) and the IGN.
4. Test the system through all of the available modes, and verify operation of all outputs, controls, and modes. Refer to the sequence of operations for each mode, to assist in verifying proper operation. Make the necessary repairs and proceed to Steps 5 and 6.
5. If no abnormal operating conditions appear in the test mode, exit the test mode by turning the power "Off" at the main power disconnect switch and removing the test mode connections.
6. Refer to the individual component test procedures if other components are suspect.

# Trouble Shooting

---

## Heating Failure

Verify Heat Failure by Ignition Module (IGN) LED indicator:

OFF: No Power or Failure

ON: Normal

Slow Flash: Normal, Heat Call

Fast Flash: Error Code:

1 Flash: No Communication

2 Flashes: System Lockout

3 Flashes: Pressure Switch Fail

4 Flashes: TC01 or TC02 Open

5 Flashes: Flame w/o Gas Valve

6 Flashes: Flame Rollout Open

## Cooling Failure

1. Cooling and heating set point (slide pot) on the thermostat has failed.
2. CC1 or CC2 24 VAC control circuit has opened, check CC1 & CC2 coils, and any of the controls below that apply to the unit (HPC1, HPC2, LPC1, LPC2, Frostat™).

## Resetting Cooling and Ignition Lockouts

Cooling Failures and Ignition Lockouts are reset in an identical manner. Method 1 explains resetting the system from the space; Method 2 explains resetting the system at the unit.

### Method 1

To reset the system from the space, turn the "Mode" selection switch at the thermostat to the "Off" position. After approximately 30 seconds, turn the "Mode" selection switch to the desired mode, i.e. Heat, Cool or Auto.

### Method 2

To reset the system at the unit, cycle the unit power by turning the disconnect switch "Off" and then "On".

## Unit Economizer Control (ECA) Test Procedures

### Electro Mechanical Control

This series of tests will allow you to diagnose, and determine where, and if a problem exists in the system economizer operation. Test 1 determines if the problem is in the Unit, or if it is in the ECA. Test 2 tests sensor inputs. Test 3 tests the resistors and sensors. Conduct the tests in numerical order until problem is found.

#### Test 1

Verifying that the economizer actuator (ECA) is functional:

1. Using the "Test Mode" described in the "System Start-Up" section, put the unit into the economizer mode and verify that the economizer actuator (ECA) drives fully open (approximately 90 seconds).
2. If the ECA is not driving the dampers, verify that 24 VAC is between the ECA terminals TR and TR1 is present. If 24 volts is not present, a wiring or terminal problem exists from the control transformer. Make any necessary repairs, see wiring diagrams to troubleshoot.
3. If 24 VAC is present, adjust the minimum position potentiometer fully clockwise. If the actuator does not drive, the economizer actuator is bad. Replace the ECA.

#### Test 2

Testing the ECA resistors and sensors

1. Testing the Mixed Air Sensor (MAS). Disconnect the wires connected to T and T1 on the ECA, and;
  - a. Measure the resistance of the sensor between the wires 180B and 181B.
  - b. Measure the temperature at the MAS location. Using the Temperature versus Resistance chart, verify the accuracy of the MAS.

Replace the sensor if it is out of range.

2. Testing the Outdoor Air Switch. If the temperature is above 60 degrees, it will need to be chilled. Measure the resistance of the sensor on the ECA SO and +.

The resistance should be approximately 390 Ohms.

Replace the Switch if it is open.

Replace the ECA if it is out of range.

3. Testing the R1 Resistance. Measure the resistance of the sensor on the ECA SR and +.

The resistance should be approximately 420 Ohms.

Replace the ECA if it is out of range.

4. Testing the R2 Resistance. Measure the resistance of the sensor on the ECA P and P1.

The resistance should be approximately 130 Ohms.

Replace the ECA if it is out of range.

# Wiring Diagrams

---

**Note:** For easier access, published unit wiring diagrams (individual, separate diagrams for unitary product lines) will become available via e-Library instead of through wiring manuals after 2007. For diagrams prior to 2008 please refer to wiring diagram books Y\_C-SVE001C-EN or Y\_C-SVE002C-EN for cooling only units.

Drawing Number	Description
<b>Connection Diagrams</b>	
4366-1000	230v/60hz/3ph — 2 - 5 Ton Single Stage Gas Heat / Direct Drive Motor
4366-1002	230v/60hz/1ph — 2 - 5 Ton Single Stage Gas Heat / Direct Drive Motor
4366-1004	460-575v/60hz/3ph — 3 Ton Single Stage Gas Heat / Direct Drive Motor
4366-1005	460-575v/60hz/3ph — 2 - 7.5 Ton Single Stage Gas Heat / Belt Drive Motor
4366-1011	460-575v/60hz/3ph — 4 - 5 Ton Single Stage Gas Heat / Oversize Drive Motor
4366-1016	230v/60hz/3ph — 2 - 7.5 Ton Single Stage Gas Heat / Belt Drive Motor
4366-1017	230v/60hz/3ph — 2 - 5 Ton Single Stage Gas Heat / Oversize Drive Motor
4366-1018	230v/60hz/1ph — 2 - 5 Ton Single Stage Gas Heat / Oversize Drive Motor
4366-1032	460-575v/60hz/3ph — 4 - 5 Ton Single Stage Gas Heat / Direct Drive Motor
4366-1033	230v/60hz/3ph — 7.5 - 10 Ton Gas Heat / Dual Compressor
4366-1034	460-575v/60hz/3ph — 7.5 - 10 Ton Gas Heat / Dual Compressor
4366-1500	230v/60hz/1ph — Single Stage Gas Heat / Direct Drive
4366-1501	230v/60hz/1ph — 3 - 5 Ton Single Stage Gas Heat / Direct Drive
4366-1502	230v/60hz/3ph — Single Stage Gas Heat / Direct Drive
4366-1503	230v/60hz/3ph — 3 - 5 Ton Single Stage Gas Heat / Direct Drive
4366-1504	230v/60hz/3ph — 3 - 5 Ton Single Stage Gas Heat / Oversize Motor
4366-1513	2 - 3 Ton Single Stage Gas Heat / Direct Drive
4366-1514	460-575v/60hz/3ph — 3 Ton Gas Heat / Direct Drive
4366-1515	460-575v/60hz/3ph — 4 - 5 Ton Gas Heat / Oversize Motor
4366-1516	460-575v/60hz/3ph — 3 - 5 Ton Gas Heat / Belt Drive
4366-1517	460-575v/60hz/3ph — 4 - 5 Ton Single Stage Gas Heat / Direct Drive
4366-1518	460-575v/60hz/3ph — 4 - 5 Ton Gas Heat / Direct Drive
4366-1519	230v/60hz/1ph — Single Stage Gas Heat / Oversize Motor
4366-1520	230v/60hz/1ph — 3 - 5 Ton Single Stage Gas Heat / Oversize Motor
4366-1521	230v/60hz/3ph — Single Stage Gas Heat / Belt Drive
4366-1522	230v/60hz/3ph — 3 - 5 Ton Single Stage Gas Heat / Belt Drive
4366-1523	460-575v/60hz/3ph — Single Stage Gas Heat / Belt Drive
4366-1525	230v/60hz/3ph — Single Stage Gas Heat / Oversize Motor
4366-1526	460-575v/60hz/3ph — 4 - 5 Ton Single Stage Gas Heat / Oversize Motor
4366-1529	230v/60hz/3ph — 7.5 - 10 Ton Gas Heat / Dual Compressor
4366-1530	230v/60hz/3ph — 7.5 - 10 Ton Gas Heat / Dual Compressor
4366-1531	460-575v/60hz/3ph — 7.5 - 10 Ton Gas Heat / Dual Compressor
4366-1532	460-575v/60hz/3ph — 7.5 - 10 Ton Gas Heat / Dual Compressor
4366-1537	230v/60hz/3ph — 6 - 7.5 Ton Gas Heat / Single Compressor
4366-1538	460-575v/60hz/3ph — 6 - 7.5 Ton Gas Heat / Single Compressor
4366-1539	230v/60hz/3ph — 6 - 7.5 Ton Gas Heat / Single Compressor
4366-1540	460-575v/60hz/3ph — 6 - 7.5 Ton Gas Heat / Single Compressor
4366-4562	230v/60Hz/1Ph — 3 - 5 Ton R410A / Direct Drive Indoor Motor
4366-4564	230v/60Hz/1Ph — 3 - 4 Ton R410A / Direct Drive Indoor Motor
4366-4576	230v/60Hz/1Ph — 3 - 5 Ton R410A
4366-4705	230v/60Hz/1Ph — 5 Ton R410A / Direct Drive Indoor Motor

## Wiring Diagrams

---

<b>Drawing Number</b>	<b>Description</b>
4366-5163	230v/60Hz/3Ph — 3 - 5 Ton R410A / Hi Eff
4366-5164	460v/60Hz/3Ph — 3 - 5 Ton R410A / Hi Eff
4366-5183	230v/60Hz/3Ph — 3 - 4 Ton R410A / Hi Eff / Direct Drive Indoor Motor
4366-5184	230v/60Hz/3Ph— 5 Ton R410A / Hi Eff / Direct Drive Indoor Motor
4366-5185	230v/60Hz/3Ph — 3 - 4 Ton Hi Eff / R410A / Direct Drive Indoor Motor
4366-5186	230v/60Hz/3Ph — 5 Ton R410A / Hi Eff / Direct Drive Indoor Motor
4366-5200	460v/60Hz/3Ph — 3 - 4 Ton R410A / Hi Eff / Direct Drive Indoor Motor
4366-5201	460v/60Hz/3Ph — 5 Ton R410A / Hi Eff / Direct Drive Indoor Motor
4366-5202	460v/60Hz/3Ph — 3 - 4 Ton R410A / Direct Drive Indoor Motor
4366-5203	460v/60Hz/3Ph — 5 Ton R410A / Direct Drive Indoor Motor
<b>Control Diagrams</b>	
4366-1001	Single Stage Gas Heat / Direct Drive
4366-1027	2 - 5 Ton Single Stage Gas Heat / Belt Drive or Oversize Motor
4366-1045	6 - 7.5 Ton Gas Heat / Single Compressor
4366-1039	7.5 - 10 Ton Gas Heat / Dual Compressor
4366-4702	5 Ton 230v/1Ph / R410A Std Eff — 5 Ton R410A Hi Eff / Direct Drive Indoor Motor
4366-4570	3 - 4 Ton 230v/1Ph / R410A Std Eff — 3 - 4 Ton R410A Hi Eff / Direct Drive Indoor Motor
4366-1031E	Through the Base Utility Schematic
4366-1006	2 - 5 Ton Single Stage Gas Heat / Direct Drive
4366-1015	2 - 5 Ton Single Stage Gas Heat / Belt Drive or Oversize Motor
4366-1042	7.5 -10 Ton Gas Heat
4366-1039	7.5 - 10 Ton Gas Heat / Dual Compressor
4366-1047	Novar Schematic 3051
4366-4703	5 Ton 230v/1Ph / R410A Std Eff — 5 Ton R410A Hi Eff / Direct Drive Indoor Motor
4366-4571	3 - 4 Ton 230v/1Ph / R410A Std Eff — 3 - 4 Ton R410A Hi Eff /Direct Drive Indoor Motor
4366-1048	CO2 Sensor / Ventilation Override Schematic

# Limited Warranty

---

## Combination Gas Electric Air Conditioner

**YCC, YCD, YCH, YCP, YSC and YHC (Parts Only)**

### Models Less Than 20 Tons for Residential Use\*

This limited warranty is extended by Trane to the original purchaser and to any succeeding owner of the real property to which the Combination Gas Electric Air Conditioner is originally affixed, and applies to products purchased and retained for use within the U.S.A. and Canada.

If any part of your Combination Gas Electric Air Conditioner fails because of a manufacturing defect within five years from the date of the original purchase, Warrantor will furnish without charge the required replacement part. Any local transportation, related service labor, diagnosis calls, air filters, refrigerant and related items are not included.

If the sealed motor-compressor fails because of a manufacturing defect within five years from the date of original purchase, Warrantor will furnish without charge the required replacement compressor. Any local transportation, related service labor, diagnosis calls, refrigerant and related items are not included.

In addition, if the steel heat exchanger fails because of a manufacturing defect within the sixth through tenth year from the date of original purchase, Warrantor will furnish without charge a replacement heat exchanger. Any local transportation, related service labor and diagnosis calls are not included.

This limited warranty does not cover failure of your combination gas electric air conditioner if it is damaged while in your possession, failure attributable or caused by unreasonable use of the combination gas electric air conditioner and/or failure to properly maintain the combination gas electric air conditioner as set forth in the Use and Care manual.

This limited warranty applies to product installed on or after 10/1/2001 where product is manufactured after 1/1/2000. This limited warranty is not retroactive to any installations prior to 10/1/2001 or on product produced prior to 2000.

THE LIMITED WARRANTY AND LIABILITY SET FORTH HEREIN ARE IN LIEU OF ALL OTHER WARRANTIES AND LIABILITIES, WHETHER IN CONTRACT OR IN NEGLIGENCE, EXPRESS OR IMPLIED, IN LAW OR IN FACT, INCLUDING IMPLIED WARRANTIES OF MERCHANTABILITY AND FITNESS FOR PARTICULAR USE, AND IN NO EVENT SHALL WARRANTOR BE LIABLE FOR ANY INCIDENTAL OR CONSEQUENTIAL DAMAGES.

Some states do not allow limitations on how long an implied limited warranty lasts or do not allow the exclusion or limitation of incidental or consequential damages, so the above limitation or exclusion may not apply to you. This limited warranty gives you specific legal rights, and you may also have other rights which vary from state to state.

Parts will be provided by our factory organization through an authorized service organization in your area listed in the yellow pages. If you wish further help or information concerning this limited warranty, contact:

Trane

2701 Wilma Rudolph Blvd.

Clarksville, TN 37040-1008

Attention: Manager, Product Service  
GW-618-4001

\* This limited warranty is for residential usage of this equipment and not applicable when this equipment is used for a commercial application. A commercial use is any application where the end purchaser uses the product for other than personal, family or household purposes.

## Limited Warranty

---

### Combination Gas Electric Air Conditioner

**YCY, YCY, YCX, YCC, YCD, YCH, YCP, YHC and YSC (Parts Only)**

#### Models Less Than 20 Tons for Commercial Use\*

This warranty is extended by Trane to the original purchaser and to any succeeding owner of the real property to which the Combination Gas Electric Air Conditioner is originally affixed, and applies to products purchased and retained for use within the U.S.A. and Canada. There is no warranty against corrosion, erosion or deterioration.

If any part of your Combination Gas Electric Air Conditioner fails because of a manufacturing defect within one year from the date of the original purchase, Warrantor will furnish without charge the required replacement part.

In addition, if the sealed motor-compressor fails because of a manufacturing defect within the second through fifth year from the date of original purchase, Warrantor will furnish without charge the required replacement compressor.

In addition, if the steel heat exchanger fails because of a manufacturing defect within the second through fifth year from

the date of original purchase, Warrantor will furnish without charge a replacement heat exchanger.

Warrantor's obligations and liabilities under this warranty are limited to furnishing F.O.B. Warrantor factory or warehouse at Warrantor designated shipping point, freight allowed to Buyer's city, replacement parts for Warrantor's products covered under this warranty. Warrantor shall not be obligated to pay for the cost of lost refrigerant. No liability shall attach to Warrantor until products have been paid for and then liability shall be limited solely to the purchase price of the equipment under warranty shown to be defective.

THE WARRANTY AND LIABILITY SET FORTH HEREIN ARE IN LIEU OF ALL OTHER WARRANTIES AND LIABILITIES, WHETHER IN CONTRACT OR IN NEGLIGENCE, EXPRESS OR IMPLIED, IN LAW OR IN FACT, INCLUDING IMPLIED WARRANTIES OF MERCHANTABILITY AND FITNESS FOR PARTICULAR USE, AND IN NO EVENT SHALL WARRANTOR BE LIABLE FOR ANY INCIDENTAL OR CONSEQUENTIAL DAMAGES.

Some states do not allow limitations on how long an implied warranty lasts or do not allow the exclusion or limitation of incidental or consequential damages, so the above limitation or exclusion may not apply to you. This warranty gives you specific legal rights, and you may also have other rights which vary from state to state.

Trane

2701 Wilma Rudolph Blvd.

Clarksville, TN 37040-1008

Attention: Manager, Product Service

GW-606-4800

\* This warranty is for commercial usage of said equipment and not applicable when the equipment is used for a residential application. Commercial use is any application where the end purchaser uses the product for other than personal, family or household purposes.





---

Literature Order Number	RT-SVX21F-EN
Date	February 2009
Supersedes	RT-SVX21F-EN (December 2008)

---

The manufacturer has a policy of continuous product and product data improvement and reserves the right to change design and specifications without notice.